

**cielo**  
handmade in Italy



news **Salone** del Mobile **2016**

Ceramica Cielo SpA  
Via Falerina km 7800  
01034 - Fabrica di Roma (VT)  
t +39 0761 56701 / f +39 0761 540363  
ceramicacielo.it  
info@ceramicacielo.it

# Indice

## Index

<b>Filosofia</b> Philosophy	p. 4
<b>Il laboratorio della ceramica</b> Ceramic workshop	p. 9
<b>Cielo: il nuovo mondo della ceramica</b> the new ceramic world	p. 10
<b>Catino, Milano, Narciso, Multiplo</b> design Andrea Parisio e Giuseppe Pezzano	p. 12
<b>Piatto doccia Infinito</b> Infinito shower tray	p. 60
<b>Le Terre di Cielo</b> 2° edition 2013/2016	p. 80
<b>Le Pietre</b>	p. 112

**«Dalla terra tutto  
deriva e con la terra  
tutto si trasforma  
Everything comes  
from the earth and  
the earth transforms  
everything»**





## Dal nostro passato la passione e l'amore per il nostro mestiere

Our passionate devotion to  
our craft springs from our  
history

Il nostro rapporto con il territorio, la terra e la natura è imprescindibile.  
Da qui nasce la nostra ceramica che si sviluppa attraverso un percorso ispirato alla natura,  
alla sua matericità rivelata al tatto, alla sua forte e al contempo fragile presenza intorno  
a noi.

*Our relationship with the earth, the land and nature is essential to everything we do.  
This is where our ceramic comes from, growing from the inspirations of nature, the feel of its  
materials to the touch, and its strong, yet fragile presence all around us.*

**«Il pittore non deve  
imitare altri pittori. Il  
pittore deve studiare  
ed imitare le opere  
della natura. Che è la  
maestra dei maestri.  
A painter should not  
imitate other painters.  
A painter should study  
and imitate the works  
of nature, which is the  
master of masters.»**

**Leonardo Da Vinci**



## Il laboratorio della ceramica Ceramic workshop

“Contrariamente alle logiche industriali di questi ultimi decenni, la nostra scelta è stata quella di riportare al centro “la cultura delle mani” che l’industria manifatturiera in questi ultimi anni ha distrutto poiché ossessionata dal costo orario ed industriale. La nostra ambizione è che CIELO sia una “BOTTEGA” del RINASCIMENTO del vero Made in Italy. Un laboratorio dove la “CULTURA DELLE MANI” sconfigge la meccanizzazione estrema a favore della dignità professionale delle persone, che tornano ad essere dei maestri artigiani.”

“L’UOMO E’ AL CENTRO DEL NOSTRO PROGETTO INDUSTRIALE”

*“Going against the industrial approach typical of recent decades, we chose to return focus to the “culture of handmade”, a culture that the manufacturing industry has decimated in recent times in its obsession with hourly and industrial costs. We aspire for Cielo to be a Renaissance workshop of genuine Italian-made quality. A workshop where “the culture of handmade” defeats excessive mechanization, returning professional dignity to people, rendered once again master craftspeople.”*

“PEOPLE ARE AT THE CORE OF OUR COMPANY PLAN”

Alessio Coramusi  
CEO Ceramica Cielo

**«la ceramica: è  
quella materia  
che i maestri  
artigiani conoscono,  
annusano, toccano,  
plasmano.  
ceramic: the  
material that our  
master craftspeople  
understand, breathe,  
touch, and shape.»**

## Cielo: il nuovo mondo della ceramica the new ceramic world

La Ceramica è la materia nobile per eccellenza, usata e diffusa da secoli per oggetti di grande valore. Un materiale difficile da plasmare e controllare, ma che sa regalare, a chi riesce a "DOMARLA", prodotti unici per bellezza, qualità e resistenza.

La missione di CIELO è quella di portare la ceramica oltre i limiti conosciuti, attraverso **forme, dimensioni, spessori, superfici, colori**.

I nostri prodotti esprimono, esaltano e fondono una straordinaria ed unica capacità di lavorare la Ceramica, ad un design contemporaneo e senza tempo.

*Ceramic is a noble material in the true sense of the word, used over the centuries and around the world to make the finest objects. This material is difficult to shape and control, but to those who know how to tame it, it returns the gift of things unique in their beauty, quality, and strength.*

*Cielo's mission is to bring ceramic beyond the bounds of the known in an exploration of **shapes, sizes, thicknesses, surfaces, and colors**.*

*Our products expertly merge our peerless ability to work with ceramic material with contemporary, timeless designs to achieve extraordinary results.*

**«...oltre ogni limite,  
fin dove si può  
arrivare a mostrare  
cosa la ceramica  
può raccontare o  
quali emozioni una  
sfumatura di colore  
può dare.**

**... beyond all bounds,  
taking ceramic as far  
as it can go, telling its  
stories and evoking  
the emotional impact  
of color»**

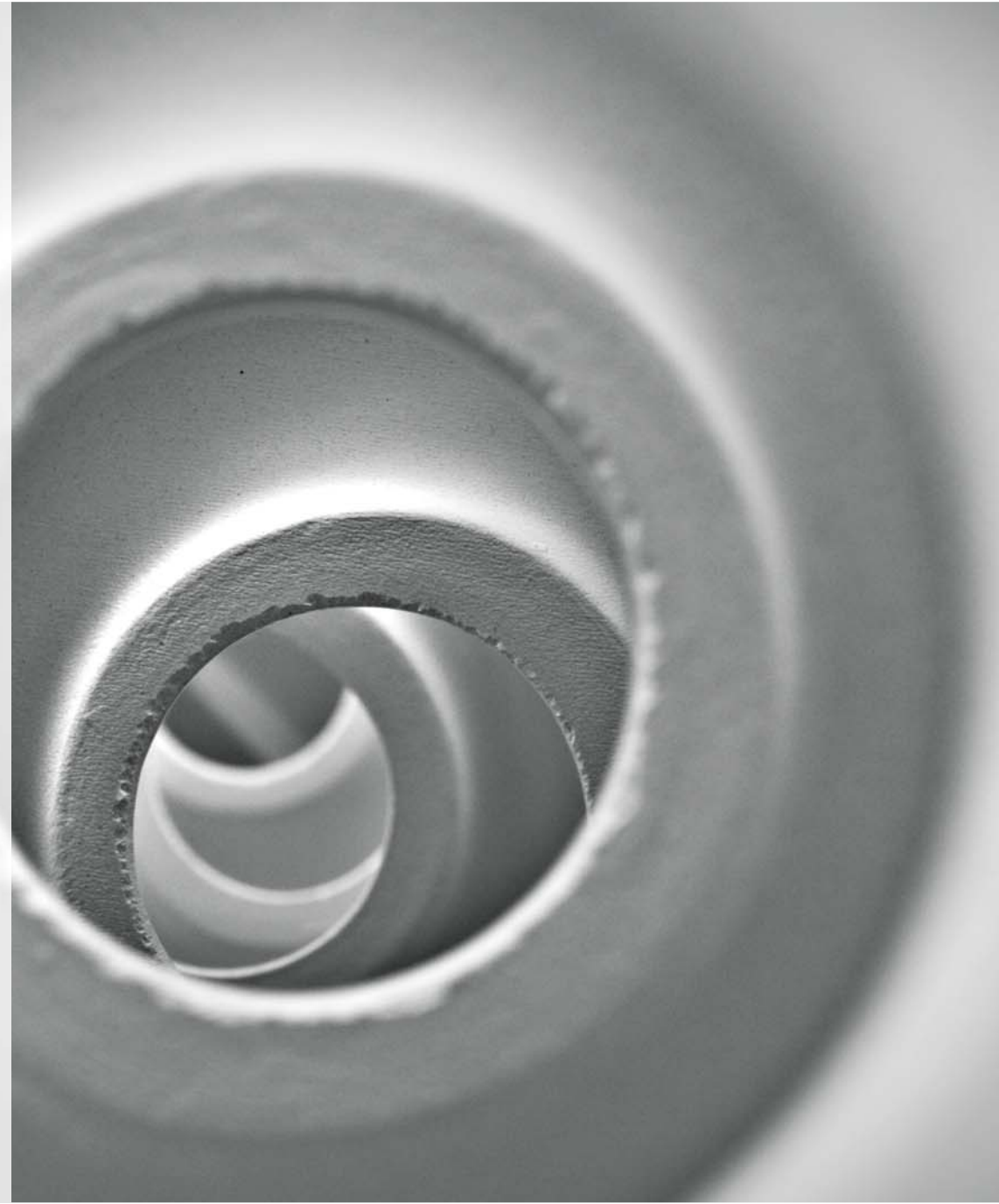

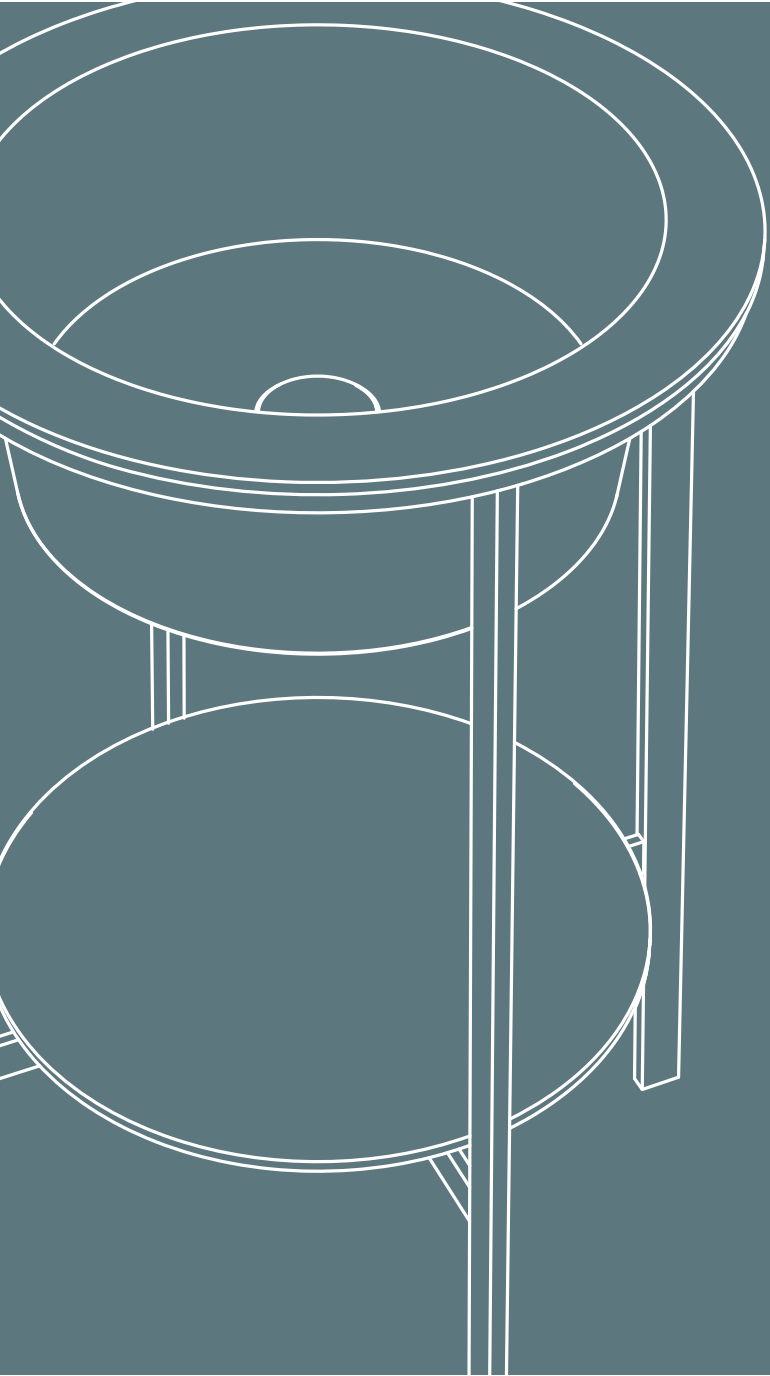

# Catino **Milano** *Narciso* multiplo

design *Andrea Parisio e Giuseppe Pezzano*

“La nobiltà della ceramica, unita all'incontro con altri materiali ed alle suggestioni delle Terre di Cielo , dà vita ad una grande versatilità compositiva ed infinite personalizzazioni”

*The nobility of ceramic , combined with other materials and suggestions of Terre di Cielo colours, gives a great versatility in composing and infinite customized solutions.*



*Andrea Parisio e Giuseppe Pezzano*

**«Cercavamo oggetti ricchi di significato...  
applicando il filtro della contemporaneità  
volevamo raccontare la bellezza della memoria»**

«We were seeking things with a wealth of meaning... We wanted to express the beauty of memory through the filter of contemporary style»

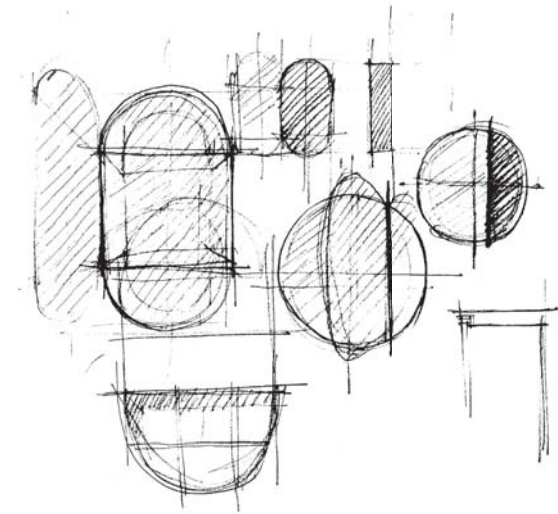

**«Abbiamo voluto realizzare dei prodotti che valorizzassero l'anima artigianale dell'azienda, la sua vocazione a proporre oggetti che fossero la dimostrazione dell'eccellenza nella lavorazione della ceramica, che solo CIELO ha»**

«Our aim was to realize some product that could valorize the artisan spirit of the factory and its vocation for presenting items that are the expression of excellence in ceramics, the one that only Cielo can get»



# Catino

design **Andrea Parisio e Giuseppe Pezzano**

**La purezza della contemporaneità interprete della memoria**

The purity of contemporary as interpretation of memory

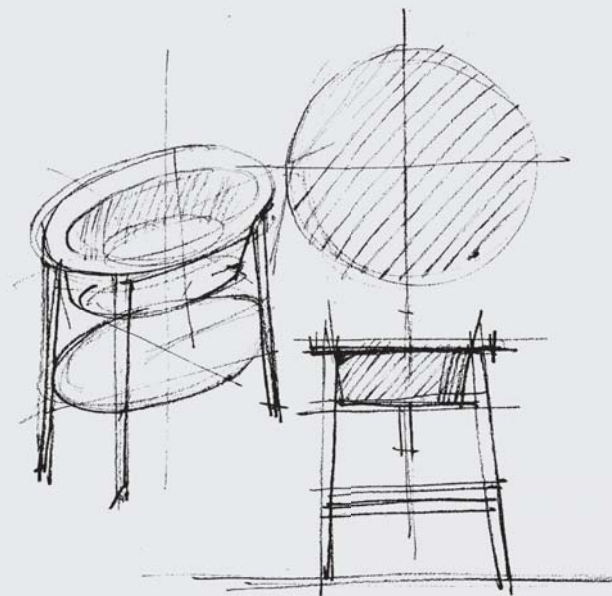

Catino: il Tondo, l'Ovale e il Doppio, tre diverse interpretazioni di un unico oggetto, che integrano armoniosamente strutture in acciaio nelle finiture Nero Matt e Bronzo spazzolato, lavabi in ceramica nelle 16 finiture della gamma Terre di Cielo e piani in ceramica, marmo o un comodo cassetto contenitore. Completano la collezione due specchi contenitori Tondo e Ovale dalle linee essenziali e una serie di elementi porta salviette e porta oggetti.

*Catino: the Round, the Oval and the Double, three different interpretations of same product, which harmonically combines frameworks made of steel and available in Nero Matt or Bronzo Spazzolato with ceramic washbasins in 16 colours of Terre di Cielo range and ceramic or marble shelves as well as a convenient storage drawer. Collection is completed with 2 mirrors cabinets, Round and Oval of essential design, and a full range of accessories such as towel rails and holders.*



Catino Ovale  
lavabo/washbasin Brina  
piano/shelf Brina  
struttura/framework Nero Matt  
70 x 50 x h83

## Lavabi Washbasins

### Catino Tondo 50

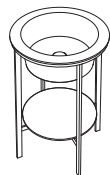

Catino 50 con piano  
Catino 50 with shelf  
Ø50 x h83

### Catino Ovale 70



Catino 70 con piano  
Catino 70 with shelf  
70 x 50 x h83

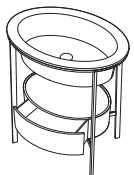

Catino 70 con cassetto  
Catino 70 with drawer  
70 x 50 x h83

### Catino Ovale 70 monoforo predisposto 3 fori 1 hole prepared 3 holes



Catino 70 monoforo predisposto  
3 fori, con piano  
Catino 70 with 1 hole prepared 3  
holes, with shelf  
70 x 50 x h83

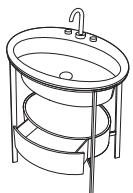

Catino 70 monoforo predisposto 3 fori,  
con cassetto  
Catino 70 with 1 hole prepared 3 holes,  
with drawer  
70 x 50 x h83

### Catino Doppio 110 monoforo predisposto 3 fori 1 hole prepared 3 holes

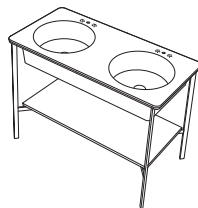

Catino 110 monoforo predisposto 3 fori, con  
piano  
Catino 110 with 1 hole prepared 3 holes, with  
shelf  
110 x 54 x h83

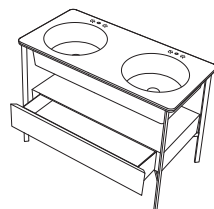

Catino 110 monoforo predisposto 3 fori,  
con cassetto  
Catino 110 with 1 hole prepared 3 holes, with  
drawer  
110 x 54 x h83

## Specchi e accessori Mirrors and accessories

### Specchi contenitori Mirror cabinets

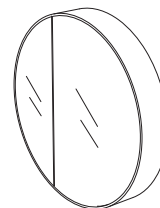

Specchio Round Box  
Round Box mirror  
Ø90 x 12

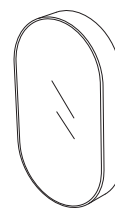

Specchio Oval Box  
Oval Box mirror  
90 x 50 x 12

### Portasciugamani Towel rails

installazione a parete  
wall-hung installation

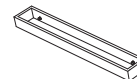

Portasciugamani versione rettangolare  
disponibile in più formati  
Towel rail, rectangular version, available in  
several sizes



Portasciugamani versione tonda  
disponibile in più formati  
Towel rail, round version,  
available in several sizes

**materiale:** acciaio, ottone  
**material:** steel, brass

**finiture\_ finishes**

- Nero Matt
- Bronzo Spazzolato
- Inox Satinato
- Cromo

### Accessori - alcuni esempi di composizione Accessories - some example of composition

installazione a parete  
wall-hung installation

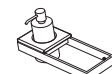

Porta dispenser  
Dispenser holder



Porta sapone  
Soap holder



Porta rotolo singolo  
Single roll holder

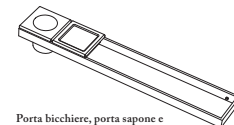

Porta bicchiere, porta sapone e  
portasciugamani  
Cup holder, soap holder, and  
towel rail

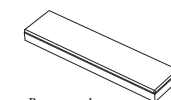

Porta mensola  
Shelf holder

### struttura framework

**materiale:** acciaio, ottone  
**material:** steel, brass

**finiture\_ finishes**

- Nero Matt
- Bronzo Spazzolato
- Inox Satinato
- Cromo

### accessori accessories

**materiale:** LivingTec, legno laccato o in  
essenza  
**material:** Lacquer or wooden finish,  
LivingTec

**LivingTec**

- Bianco

**essenze\_ wooden finishes**

- Rovere Naturale
- Rovere Sbiancato
- Rovere Grigio
- Rovere Moka
- Rovere Nero

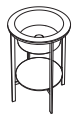

Catino Tondo  
lavabo/washbasin Talco  
struttura/framework Nero Matt  
piano/shelf Marmo Bianco Carrara  
Ø50 x h83





**Catino Tondo**  
lavabo/washbasin Talco  
struttura/framework Bronzo Spazzolato  
piano/shelf Marmo Bianco Carrara  
Ø50 x h83



# Catino Tondo

Catino Tondo 50 con piano  
 Catino Tondo 50 with shelf  
 Ø50 x h83

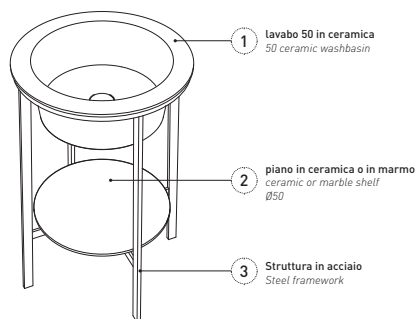

## Materiali e finiture *Materials and finishes*

### 1 lavabo washbasin

materiale: ceramica  
 material: ceramic

Le Terre di Cielo *ceramica\_ceramic*

- |           |            |
|-----------|------------|
| ● Talco   | ● Arenaria |
| ● Pomice  | ● Avena    |
| ● Brina   | ● Lino     |
| ● Basalto | ● Agave    |
| ● Lavagna | ● Muschio  |
| ● Cemento | ● Polvere  |
| ● Fango   | ● Cipria   |
| ● Cacao   | ● Canapa   |

### 2 piano shelf

materiale: ceramica o marmo  
 material: ceramic or marble

*ceramica\_ceramic* Le Terre di Cielo

- |           |            |
|-----------|------------|
| ● Talco   | ● Arenaria |
| ● Pomice  | ● Avena    |
| ● Brina   | ● Lino     |
| ● Basalto | ● Agave    |
| ● Lavagna | ● Muschio  |
| ● Cemento | ● Polvere  |
| ● Fango   | ● Cipria   |
| ● Cacao   | ● Canapa   |

*marmo\_marble*

- Bianco Carrara Gioia
- Nero Marquinia

### 3 struttura framework

materiale: acciaio verniciato  
 material: painted steel

*verniciature\_coatings*

- Nero Matt
- Bronzo Spazzolato

## Infinite possibilità di personalizzazione *Infinite customized solutions*

*esempi\_examples*



1



2



3

1 lavabo/washbasin Talco  
 piano/shelf Brina  
 struttura/framework Nero Matt

2 lavabo/washbasin Polvere  
 piano/shelf Polvere  
 struttura/framework Nero Matt

3 lavabo/washbasin Cemento  
 piano/shelf Talco  
 struttura/framework Nero Matt



Specchio Argo  
a soffitto  
*Argo ceiling-mounted  
mirror*



Catino Ovale monoforo  
predisposto 3 fori  
*Catino Ovale with 3 hole prepared 3 holes  
lavabo/washbasin Cipria  
piano/shelf Marmo Bianco Carrara  
struttura/framework Nero Matt  
70 x 50 x h83*



Catino Ovale  
lavabo/washbasin Talco  
cassetto/drawer Rovere Nero  
struttura/framework Nero Matt  
70 x 50 x h83



# Catino Ovale

**Catino Ovale 70 con piano**  
Catino Ovale 70 with shelf  
70 x 50 x h83

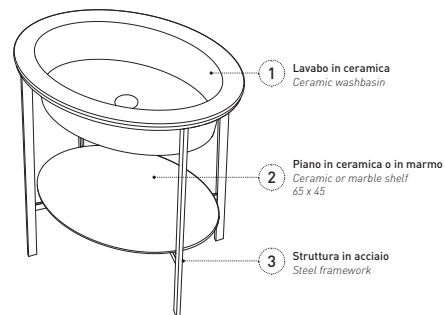

**Catino Ovale 70 con cassetto**  
Catino Ovale 70 with drawer  
70 x 50 x h83

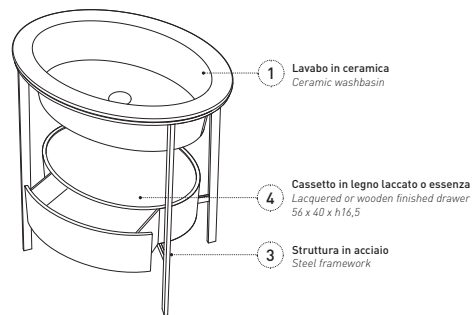

## Materiali e finiture *Materials and finishes*

### 1 lavabo washbasin

**materiale:** ceramica  
**material:** ceramic

ceramica\_ceramic **Le Terre di Cielo**

- |           |            |
|-----------|------------|
| ● Talco   | ● Arenaria |
| ● Pomice  | ● Avena    |
| ● Brina   | ● Lino     |
| ● Basalto | ● Agave    |
| ● Lavagna | ● Muschio  |
| ● Cemento | ● Polvere  |
| ● Fango   | ● Cipria   |
| ● Cacao   | ● Canapa   |

### 2 piano shelf

**materiale:** ceramica o marmo  
**material:** ceramic or marble

ceramica\_ceramic **Le Terre di Cielo**

- |           |            |
|-----------|------------|
| ● Talco   | ● Arenaria |
| ● Pomice  | ● Avena    |
| ● Brina   | ● Lino     |
| ● Basalto | ● Agave    |
| ● Lavagna | ● Muschio  |
| ● Cemento | ● Polvere  |
| ● Fango   | ● Cipria   |
| ● Cacao   | ● Canapa   |

marmo\_marble

- Bianco Carrara Gioia
- Nero Marquinia

### 3 struttura framework

**materiale:** acciaio  
**material:** steel

verniciature\_coatings

- Nero Matt
- Bronzo Spazzolato

### 4 cassetto drawer

**materiale:** legno laccato o in essenza  
**material:** lacquer or wooden finish

laccature\_lacquers

- |            |           |
|------------|-----------|
| ● Talco    | ● Avena   |
| ● Pomice   | ● Cemento |
| ● Brina    | ● Basalto |
| ● Arenaria | ● Muschio |

essenze\_wooden finishes

- Rovere Naturale
- Rovere Sbiancato
- Rovere Grigio
- Rovere Moka
- Rovere Nero

## Infinite possibilità di personalizzazione *Infinite customized solutions*

esempi\_examples



1



2



3

1 lavabo/washbasin Lino  
piano/shelf Lino  
struttura/framework Nero Matt

2 lavabo/washbasin Fango  
piano/shelf Fango  
struttura/framework Nero Matt

3 lavabo/washbasin Canapa  
piano/shelf Canapa  
struttura/framework Nero Matt

# Catino Ovale

monoforo predisposto 3 fori\_ 1 hole prepared 3 holes

**Catino Ovale 70 monoforo predisposto 3 fori, con piano**  
*Catino Ovale 70 with 1 hole prepared 3 holes, with shelf*  
 70 x 50 x h83

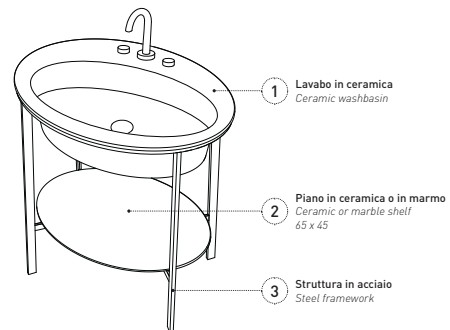

**Catino Ovale 70 monoforo predisposto 3 fori, con cassetto**  
*Catino Ovale 70 with 1 hole prepared 3 holes, with drawer*  
 70 x 50 x h83

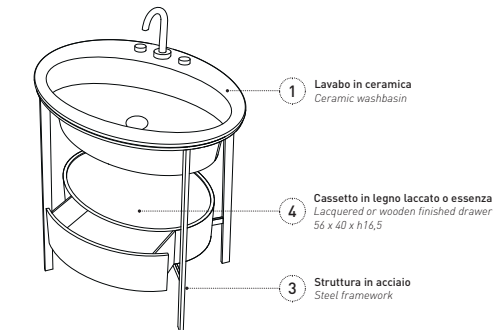

## Infinite possibilità di personalizzazione

*Infinite customized solutions*

esempi\_examples



1



2



3

## Materiali e finiture *Materials and finishes*

### 1 lavabo washbasin

materiale: ceramica  
 material: ceramic

ceramica\_ceramic **Le Terre di Cielo**

- |           |            |
|-----------|------------|
| ● Talco   | ● Arenaria |
| ● Pomice  | ● Avena    |
| ● Brina   | ● Lino     |
| ● Basalto | ● Agave    |
| ● Lavagna | ● Muschio  |
| ● Cemento | ● Polvere  |
| ● Fango   | ● Cipria   |
| ● Cacao   | ● Canapa   |

### 2 piano shelf

materiale: ceramica o marmo  
 material: ceramic or marble

ceramica\_ceramic **Le Terre di Cielo**

- |           |            |
|-----------|------------|
| ● Talco   | ● Arenaria |
| ● Pomice  | ● Avena    |
| ● Brina   | ● Lino     |
| ● Basalto | ● Agave    |
| ● Lavagna | ● Muschio  |
| ● Cemento | ● Polvere  |
| ● Fango   | ● Cipria   |
| ● Cacao   | ● Canapa   |

marmo\_marble

- |                        |
|------------------------|
| ● Bianco Carrara Gioia |
| ● Nero Marquinia       |

### 3 struttura framework

materiale: acciaio  
 material: steel

verniciature\_coatings

- |                     |
|---------------------|
| ● Nero Matt         |
| ● Bronzo Spazzolato |

### 4 cassetto drawer

materiale: legno laccato o in essenza  
 material: lacquer or wooden finish

laccature\_lacquers

- |            |           |
|------------|-----------|
| ● Talco    | ● Avena   |
| ● Pomice   | ● Cemento |
| ● Brina    | ● Basalto |
| ● Arenaria | ● Muschio |

essenze\_wooden finishes

- |                    |
|--------------------|
| ● Rovere Naturale  |
| ● Rovere Sbiancato |
| ● Rovere Grigio    |
| ● Rovere Moka      |
| ● Rovere Nero      |

1 lavabo/washbasin Lavagna  
 piano/shelf Marmo Nero Marquinia  
 struttura/framework Nero Matt

2 lavabo/washbasin Talco  
 piano/shelf Talco  
 struttura/framework Nero Matt

3 lavabo/washbasin Lavagna  
 cassetto/drawer Talco  
 struttura/framework Nero Matt



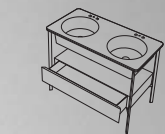

Catino Doppio  
lavabo/washbasin Cemento  
cassetto/drawer Cemento  
struttura/framework Nero Matt  
110 x 54 x h83



Specchio Round Box  
Round Box mirror  
Ø90 x h12



portasciugamani  
towel rail

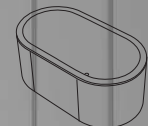

vasca Cibeles con rivestimento  
in finitura Cemento  
Cibeles bathtub with covering in  
Cemento finish

# Catino Doppio

**Catino Doppio 110 monoforo  
predisposto 3 fori, con piano**  
Catino Doppio 110 with 1 hole  
prepared 3 holes, with shelf  
110 x 54 x h83

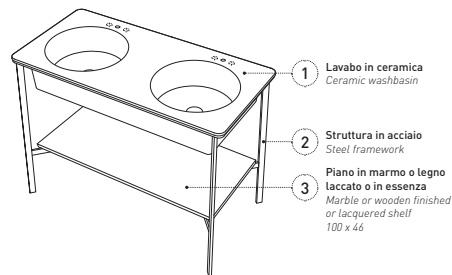

- 1 Lavabo in ceramica  
Ceramic washbasin
- 2 Struttura in acciaio  
Steel framework
- 3 Piano in marmo o legno  
laccato o in essenza  
Marble or wooden finished  
or lacquered shelf  
100 x 46

**Catino Doppio 110 monoforo  
predisposto 3 fori, con cassetto**  
Catino Doppio 110 with 1 hole prepared  
3 holes, with drawer  
110 x 54 x h83

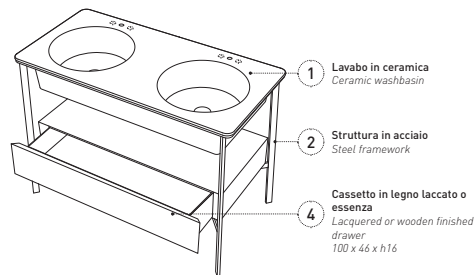

- 1 Lavabo in ceramica  
Ceramic washbasin
- 2 Struttura in acciaio  
Steel framework
- 3 Piano in marmo o legno  
laccato o in essenza  
Marble or wooden finished  
or lacquered shelf  
100 x 46
- 4 Cassetto in legno laccato o  
essenza  
Lacquered or wooden finished  
drawer  
100 x 46 x h16

## Materiali e finiture *Materials and finishes*

### 1 lavabo washbasin

**materiale:** ceramica  
**material:** ceramic

#### ceramica\_ceramic Le Terre di Cielo

- |           |            |
|-----------|------------|
| ● Talco   | ● Arenaria |
| ● Pomice  | ● Avena    |
| ● Brina   | ● Lino     |
| ● Basalto | ● Agave    |
| ● Lavagna | ● Muschio  |
| ● Cemento | ● Polvere  |
| ● Fango   | ● Cipria   |
| ● Cacao   | ● Canapa   |

### 2 struttura framework

**materiale:** acciaio  
**material:** steel

#### verniciature\_coatings

- Nero Matt
- Bronzo Spazzolato

### 3 piano shelf

**materiale:** legno laccato o in  
essenza, marmo  
**material:** lacquer, wooden or marble  
finish

#### laccature\_lacquers

- |            |           |
|------------|-----------|
| ● Talco    | ● Avena   |
| ● Pomice   | ● Cemento |
| ● Brina    | ● Basalto |
| ● Arenaria | ● Muschio |

#### essenze\_wooden finishes

- Rovere Naturale
- Rovere Sbiancato
- Rovere Grigio
- Rovere Moka
- Rovere Nero

#### marmo\_marble

- Bianco Carrara Gioia
- Nero Marquina

### 4 cassetto drawer

**materiale:** legno laccato o in essenza  
**material:** lacquer or wooden finish

#### laccature\_lacquers

- |            |           |
|------------|-----------|
| ● Talco    | ● Avena   |
| ● Pomice   | ● Cemento |
| ● Brina    | ● Basalto |
| ● Arenaria | ● Muschio |

#### essenze\_wooden finishes

- Rovere Naturale
- Rovere Sbiancato
- Rovere Grigio
- Rovere Moka
- Rovere Nero

## Infinite possibilità di personalizzazione *Infinite customized solutions*

### esempi\_examples



1 lavabo/washbasin Muschio  
cassetto/drawer Muschio  
struttura/framework Nero Matt

2 lavabo/washbasin Talco  
piano/shelf Marmo Nero Marquina  
struttura/framework Nero Matt

3 lavabo/washbasin Cemento  
piano/shelf Marmo Bianco Carrara  
struttura/framework Nero Matt

4 lavabo/washbasin Lavagna  
cassetto/drawer Pomice  
struttura/framework Nero Matt

# Round Box

**Specchio Round Box**  
Round Box mirror  
Ø90 x 12 cm

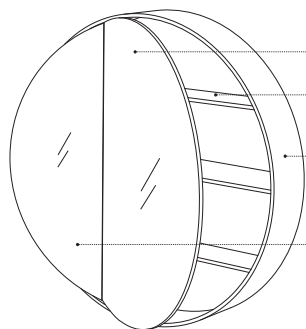
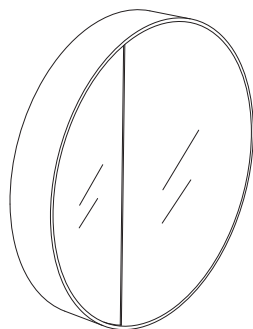
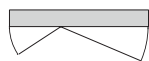

- 1 anta specchio destra  
mirror right door
- 2 ripiani  
shelves
- 3 scocca laccata Nero Matt  
lacquered box - Nero Matt
- 4 anta specchio sinistra  
mirror left door

# Oval Box

**Specchio Oval Box**  
Oval Box mirror  
90 x 50 x 12

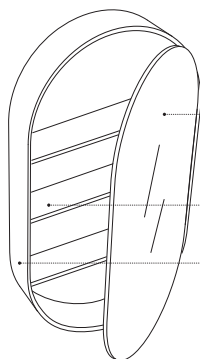
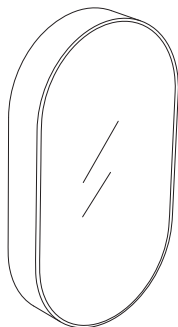

- 1 anta specchio  
mirror
- 2 ripiani  
shelves
- 3 scocca laccata Nero Matt  
lacquered box - Nero Matt



Specchio Round Box  
Round Box mirror  
Ø90 x h12



Specchio Oval Box  
Oval Box mirror  
90 x 50 x 12

# Milano

design **Andrea Parisio e Giuseppe Pezzano**

**Rigoroso e  
funzionale**  
High  
precision,  
functional  
style

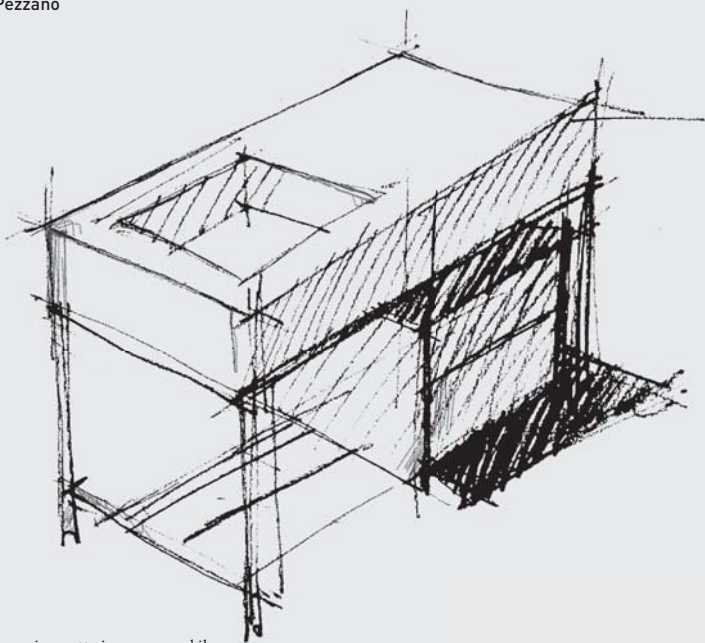

Un grande bacino e un comodo piano d'appoggio caratterizzano un mobile puro ed essenziale con piano in ceramica disponibile nelle 16 finiture della gamma Terre di Cielo con integrato un cassetto contenitore. La struttura in acciaio Nero Matt o Bronzo spazzolato può essere completata da una cassetiera in essenza o laccata.

*A large basin and a convenient top characterize a pure and essential furniture with a ceramic top available in 16 colours of Terre di Cielo range and colours of Terre di Cielo range and a storage drawer. The framework made of steel and available in matt black or brushed bronze can be completed with a wooden or lacquered drawers.*



Milano  
lavabo/washbasin Talco  
base con cassetto/base with drawer Talco  
cassettera/drawers Rovere Nero  
strutturale/framework Nero Matt  
120 x 50 x h83

# Milano

**Dimensioni**  
*Sizes*  
 120 x 50 x h83

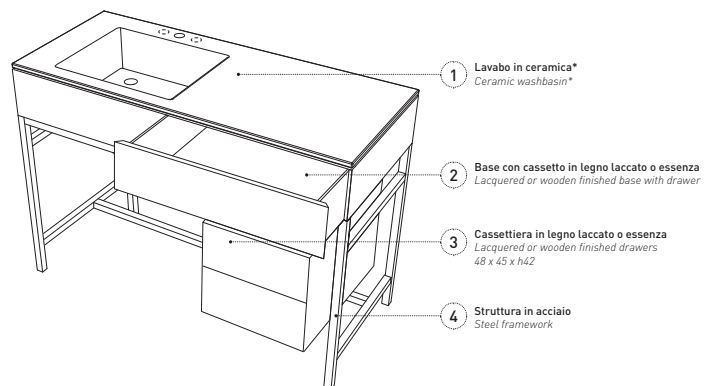

- 1 Lavabo in ceramica\*  
*Ceramic washbasin\**
- 2 Base con cassetto in legno laccato o essenza  
*Lacquered or wooden finished base with drawer*
- 3 Cassettiera in legno laccato o essenza  
*Lacquered or wooden finished drawers  
 48 x 45 x h42*
- 4 Struttura in acciaio  
*Steel framework*

\*lavabo monoforo predisposto 3 fori  
*\*washbasin with 1 hole prepared 3 holes*

## Materiali e finiture *Materials and finishes*

### 1 lavabo *washbasin*

**materiale:** ceramica  
**material:** ceramic

#### ceramica\_ceramic **Le Terre di Cielo**

- Talco
- Pomice
- Brina
- Basalto
- Lavagna
- Cemento
- Fango
- Cacao
- Arenaria
- Avena
- Lino
- Agave
- Muschio
- Polvere
- Cipria
- Canapa

### 2 base con cassetto *base with drawer*

**materiale:** legno laccato o in essenza  
**material:** lacquer or wooden finish

#### laccature\_lacquers

- Talco
- Pomice
- Brina
- Basalto
- Arenaria
- Avena
- Cemento
- Basalto
- Muschio

#### essenze\_wooden finishes

- Rovere Naturale
- Rovere Sbiancato
- Rovere Grigio
- Rovere Moka
- Rovere Nero

### 3 cassetteria *drawers*

**materiale:** legno laccato o in essenza  
**material:** lacquer or wooden finish

#### laccature\_lacquers

- Talco
- Pomice
- Brina
- Basalto
- Arenaria
- Avena
- Cemento
- Basalto
- Muschio

#### essenze\_wooden finishes

- Rovere Naturale
- Rovere Sbiancato
- Rovere Grigio
- Rovere Moka
- Rovere Nero

### 4 struttura *framework*

**materiale:** acciaio  
**material:** steel

#### verniciature\_coatings

- Nero Matt
- Bronzo Spazzolato

## Infinite possibilità di personalizzazione *Infinite customized solutions*

**esempi** *examples*



1



2



3



4

1 lavabo/washbasin Muschio  
 base cassetto/base with drawer Muschio  
 struttura/framework Nero Matt

2 lavabo/washbasin Arenaria  
 base cassetto/base with drawer Arenaria  
 cassetteria/drawers Rovere Nero  
 struttura/framework Nero Matt

3 lavabo/washbasin Pomice  
 base cassetto/base with drawer Pomice  
 cassetteria/drawers Rovere naturale  
 struttura/framework Nero Matt

4 lavabo/washbasin Polvere  
 base cassetto/base with drawer Polvere  
 cassetteria/drawers Rovere Grigio  
 struttura/framework Nero Matt

# Narciso

design **Andrea Parisio e Giuseppe Pezzano**

**Eclettico e  
vanitoso**  
Eclectic  
and vain

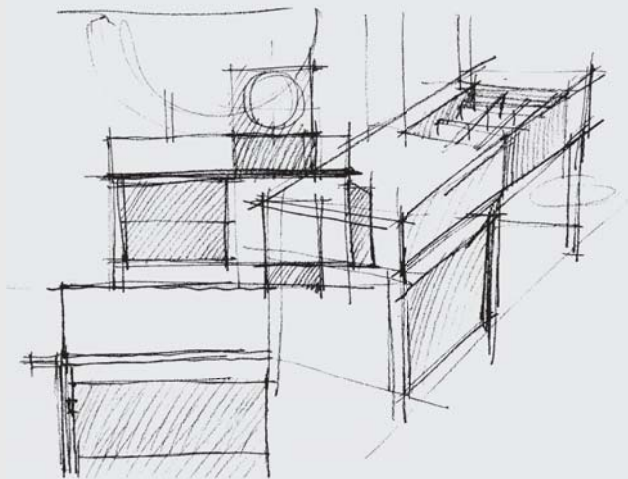

Innovativo lavabo in ceramica con grande bacino e comodo piano d'appoggio, con la possibilità di integrare un elemento "Make Up" dotato di specchio e portaoggetti.

Un prodotto elegante, funzionale, versatile... un po' NARCISO.

Il lavabo è personalizzabile nelle 16 finiture della gamma Terre di Cielo. Il "Make Up" può essere laccato o in essenza.

La struttura in acciaio Nero matt o Bronzo spazzolato può essere arricchita da una serie di accessori: un porta salviette laterale, una borsa porta biancheria in cuoio naturale e due cassettiere. La voluta asimmetria della struttura dà la possibilità di sedersi agevolmente... accomodatevi!

*Innovative washbasin in ceramic with a large basin and a convenient top, in which it is possible to integrate "make-up" element with mirror and beauty-case.*

*A very elegant, functional and versatile product...like a real Narciso.*

*The washbasin is available in 16 colours of Terre di Cielo range. The "make-up" element can be lacquered or in wooden finish.*

*The framework made of steel and available in matt black or brushed bronze and it can be enriched with a full range of accessories: a lateral towel-rail, a laundry bag in real leather and two drawers.*

*The intentional asymmetric shape offers the possibility to sit easily...please take your seat!*



Specchio Argo  
a soffitto  
Argo ceiling-mounted  
mirror

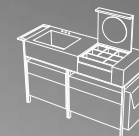

Narciso  
lavabo/washbasin Pomice  
elemento "Make up"/Make up element Pomice  
cassettiere/drawers Cemento  
struttura/framework Nero Matt  
sacca/laundry bag Cuoio Naturale  
130 x 50 x h83

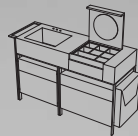

Narciso  
lavabo/washbasin Talco  
elemento "Make up"/"Make up" element Rovere  
Naturale  
cassettiera/drawers Rovere Naturale  
struttura/framework Nero Matt  
sacca/laundry bag Cuoio Nero  
130 x 50 x h83

# Narciso

**Dimensioni**  
*Sizes*  
 130 x 50 x 83h

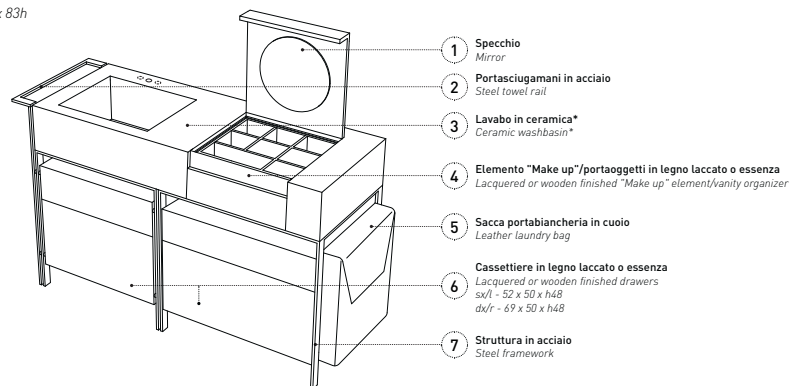

- ① Specchio  
*Mirror*
- ② Portasciugamani in acciaio  
*Steel towel rail*
- ③ Lavabo in ceramica\*  
*Ceramic washbasin\**
- ④ Elemento "Make up"/portaoggetti in legno laccato o essenza  
*Lacquered or wooden finished "Make up" element/vanity organizer*
- ⑤ Sacca portabiancheria in cuoio  
*Leather laundry bag*
- ⑥ Cassettiere in legno laccato o essenza  
*Lacquered or wooden finished drawers*  
sx/l - 52 x 50 x h48  
dx/r - 69 x 50 x h48
- ⑦ Struttura in acciaio  
*Steel framework*

\*lavabo monoforo predisposto 3 fori  
*\*washbasin with 1 hole prepared 3 holes*

## Materiali e finiture *Materials and finishes*

### ③ lavabo *washbasin*

**materiale:** ceramica  
**material:** ceramic

**ceramica\_ceramic** **Le Terre di Cielo**

- Talco
- Pomice
- Brina
- Basalto
- Lavagna
- Cemento
- Fango
- Cacao
- Arenaria
- Avena
- Lino
- Agave
- Muschio
- Polvere
- Cipria
- Canapa

### ④ ⑥ elemento "Make up" e cassettiere *"Make up" element and drawers*

**materiale:** legno laccato o in essenza  
**material:** lacquer or wooden finish

**laccature\_lacquers**

- Talco
- Pomice
- Brina
- Arenaria
- Avena
- Cemento
- Basalto
- Muschio

**essenze\_wooden finishes**

- Rovere Naturale
- Rovere Sbiancato
- Rovere Grigio
- Rovere Moka
- Rovere Nero

### ② ⑦ struttura e portasciugamani *framework and towel rail*

**materiale:** acciaio  
**material:** steel

**verniciature\_coatings**

- Nero Matte
- Bronzo Spazzolato

### ④ sacca *laundry bag*

**materiale:** cuoio naturale  
**material:** real leather

- Nero
- Cuoio

## Infinite possibilità di personalizzazione *Infinite customized solutions*

**esempi\_examples**



①



②



③



④

① lavabo/washbasin Arenaria  
 elemento "Make up" Arenaria  
 struttura/framework Nero Matt

② lavabo/washbasin Avena  
 elemento "Make up" Avena  
 cassetteria/drawers Rovere Nero  
 struttura/framework Nero Matt

③ lavabo/washbasin Agave  
 elemento "Make up" Agave  
 cassetteria/drawers Avena  
 struttura/framework Nero Matt

④ lavabo/washbasin Fango  
 elemento "Make up" Fango  
 cassetteria/drawers Rovere Nero  
 struttura/framework Nero Matt



## Esempi di composizione

*Example of composition*

Per ottenere la configurazione più rispondente alle proprie esigenze tutti gli accessori possono essere liberamente abbinati.  
For obtaining the composition you prefer, all accessories can be combined following your needs.

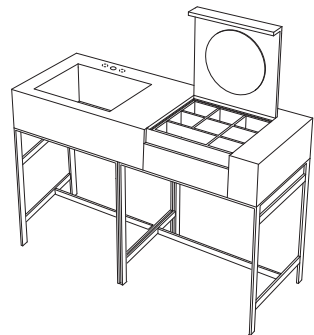

Composizione con elemento "Make up"  
*Composition with "Make up" element*

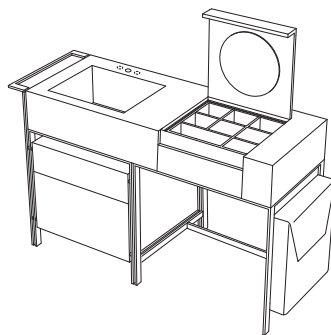

Composizione con elemento "Make up",  
cassettiera, portasciugamani e sacca porta  
biancheria  
*Composition with "Make up" element, drawers, towel  
rail, and laundry bag*

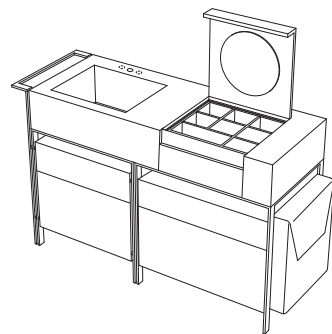

Composizione con elemento "Make up", doppia  
cassettiera, portasciugamani e sacca porta biancheria  
*Composition with "Make up" element, double drawers, towel  
rail, and laundry bag*

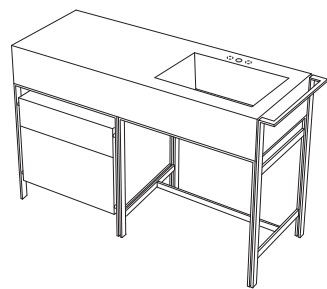

Composizione con variante lavabo senza elemento "Make up",  
con cassettiera e portasciugamani. In questa soluzione il bacino del  
lavabo è a destra e si può usufruire di un comodo piano da appoggio  
in ceramica  
*Composition without "Make up" element, with drawers and towel rail. In  
this version, the basin is on the right side and you can use a convenient  
ceramic top*

## Infinite possibilità di personalizzazione

*Infinite customized solutions*

esempi\_examples



5



6



7



8

5 lavabo/washbasin Pomice  
elemento "Make up" Rovere Moka  
cassettiera/drawers Pomice  
struttura/framework Nero Matt

6 lavabo/washbasin Polvere  
elemento "Make up" Arenaria  
cassettiera/drawers Arenaria  
struttura/framework Nero Matt

7 lavabo/washbasin Cacao  
elemento "Make up" Cacao  
cassettiera/drawers Rovere Naturale  
struttura/framework Nero Matt

8 lavabo/washbasin Cipria  
elemento "Make up" Cipria  
cassettiera/drawers Rovere Nero  
struttura/framework Nero Matt

# Multiplo

design **Andrea Parisio e Giuseppe Pezzano**

Quando la  
ceramica diventa  
componibile  
Ceramic becomes  
modular

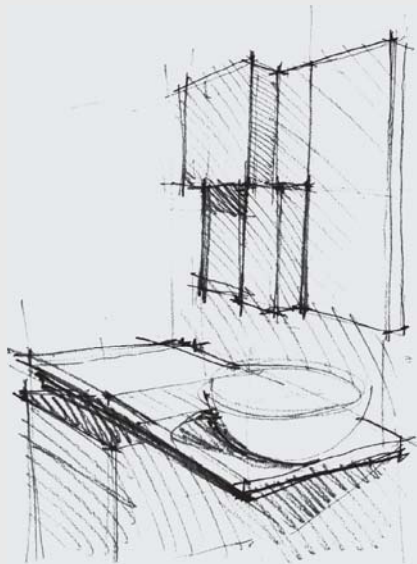

Un innovativo sistema di Piani in Ceramica che esalta la funzionalità e la semplicità. Pochi elementi danno vita ad una molteplicità di combinazioni. La Ceramica garantisce massima qualità del materiale, grande funzionalità, ed una gamma di 16 colori, il tutto integrato in strutture modulari in acciaio, eleganti mensole in essenza o laccate, pensili porta oggetti, specchi e cassettiere. I piani possono essere realizzati nelle 16 finiture della gamma Terre di CIELO. Le strutture sono in acciaio nella finitura Nero matt. I pensili e la cassettera possono essere in essenza o laccati. Il tutto integrato con pratici porta salviette e porta oggetti. Un prodotto funzionale, giovane, innovativo e trasversale, ideale sia per il residenziale che per il contract.

*This innovative system of ceramic tops takes functionality and simplicity up a notch. Just a few components make for a multitude of combinations. The use of ceramic means superior quality, excellent functionality, and a selection of 16 colors. With convenient ceramic tops, built into modular steel structures, elegant lacquered or solid wood shelves, joined by wall-hung accessory holders, mirrors and drawers.*

*The tops can be made in the 16 finishes of the Terre di Cielo line. The structures are steel in a matte black finish. The wall units and drawers may be lacquered or solid wood. Convenient towel racks and accessory holders can be added as desired. This innovative, fresh and functional design is perfect for residential and contract furnishing alike.*



lavabo/washbasin Cemento  
piano/top Cemento  
piano accessorio/lateral shelf Rovere Naturale  
struttura/framework Nero Matt  
specchio/mirror  
contentitore/cabinet Rovere Naturale

# Piani

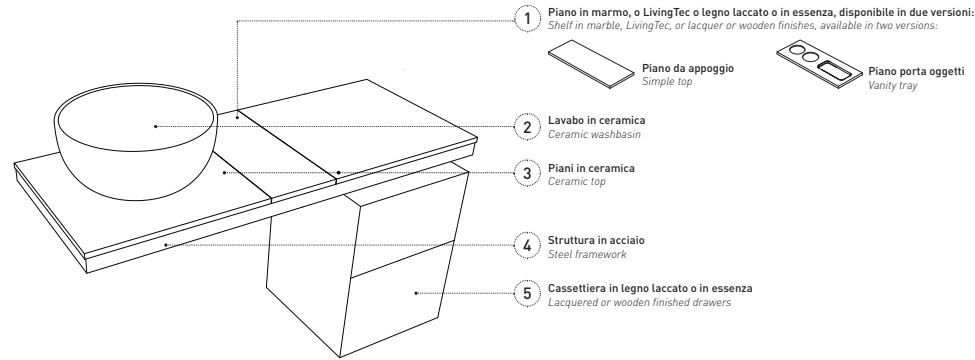

## Materiali e finiture *Materials and finishes*

### 1 piano accessorio *lateral shelf*

**materiale:** legno, marmo o LivingTec  
**material:** wood, marble or LivingTec

#### laccature\_lacquers

- Talco
- Pomice
- Brina
- Arenaria
- Avena
- Cemento
- Basalto
- Muschio

#### essenze\_wooden finishes

- Rovere Naturale
- Rovere Sbiancato
- Rovere Grigio
- Rovere Moka
- Rovere Nero

#### marmo\_marble

- Bianco Carrara Gioia
- Nero Marquina

#### LivingTec

- Bianco

### 2 3 lavabo e piani *washbasin and tops*

**materiale:** ceramica  
**material:** ceramic

#### ceramica\_ceramic **Le Terre di Cielo**

- Talco
- Pomice
- Brina
- Basalto
- Lavagna
- Cemento
- Cacao
- Arenaria
- Avena
- Lino
- Agave
- Muschio
- Polvere
- Cipria
- Canapa

### 4 struttura *framework*

**materiale:** acciaio  
**material:** steel

#### verniciature\_coatings

- Nero Matt

### 5 cassetteria *drawers*

**materiale:** legno laccato o in essenza  
**material:** lacquer or wooden finish

#### laccature\_lacquers

- Talco
- Pomice
- Brina
- Arenaria
- Avena
- Cemento
- Basalto
- Muschio

#### essenze\_wooden finishes

- Rovere Naturale
- Rovere Sbiancato
- Rovere Grigio
- Rovere Moka
- Rovere Nero

## Tipologie di composizione *Compositions*

### 40 x 29



### 50 x 48



### 70 x 48



### 90 x 48



### 120 x 48



**Componenti:**  
- piano in ceramica 40 x 29 cm  
- lavamani Minimo  
- portasciugamani opzionale

**Installazione:**  
- sospesa

**Note:**  
- versione dx/sx  
- predisposizione rubinetto su piano dx/sx

**Componenti:**  
- 40x29 cm ceramic top  
- Minimo basin  
- optional towel rail

**Installazione:**  
- wall-hung

**Note:**  
- right/left version  
- on top tap hole

**Componenti:**  
- piano in ceramica 50 x 48 cm  
- lavabo  
- struttura

**Installazione:**  
- sospesa

**Note:**  
- predisposizione rubinetto su piano dx/sx

**Componenti:**  
- 50x48 cm ceramic top  
- washbasin  
- framework  
- shelf

**Installazione:**  
- wall-hung

**Note:**  
- right or left on top tap hole

**Componenti:**  
- piano in ceramica 70/50 x 48 cm  
- lavabo  
- struttura  
- piano accessorio

**Installazione:**  
- sospesa

**Note:**  
- versione dx/sx  
- predisposizione rubinetto su piano dx/sx

**Componenti:**  
- 70/50x48 cm ceramic top  
- washbasin  
- framework  
- shelf

**Installazione:**  
- wall-hung

**Note:**  
- right/left version  
- right or left on top tap hole

**Componenti:**  
- piani in ceramica 90/70 x 48 cm  
- lavabo  
- struttura  
- piano accessorio

**Installazione:**  
- sospesa

**Note:**  
- versione dx/sx  
- predisposizione rubinetto su piano dx/sx

**Componenti:**  
- 90/70x48 cm ceramic top  
- washbasin  
- framework  
- shelf

**Installazione:**  
- wall-hung

**Note:**  
- right/left version  
- right or left on top tap hole

**Componenti:**  
- piani in ceramica 120/50 x 48 cm  
- lavabi  
- struttura  
- piano accessorio  
- cassettera a terra  
- cassettera sospesa

**Installazione:**  
- sospesa o a terra

**Note:**  
- versione dx/sx  
- predisposizione rubinetto su piano dx/sx

**Componenti:**  
- 120/50x48 cm ceramic top  
- washbasins  
- framework  
- shelf

**Installazione:**  
- floor-mounted drawers  
- suspended drawers

**Note:**  
- wall-hung or floor-mounted  
- right or left on top tap hole

Il lavabo raffigurato è solo un esempio. Per la possibilità di installazione di altri modelli va fatta una verifica tecnica preliminare. The washbasin shown is only an example. A preliminary technical review must be made to installing other models, if desired.

# Specchi/Contenitori

Mirrors/Cabinets

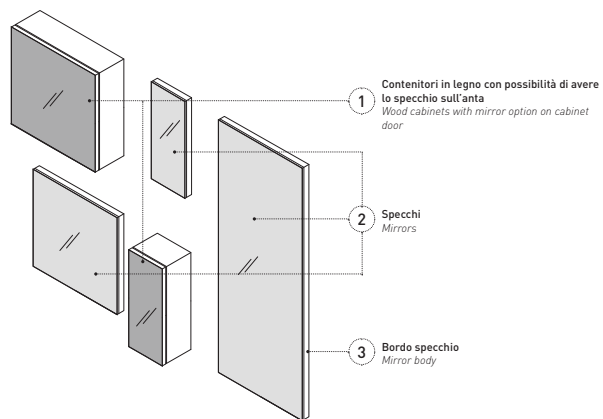

## Materiali e finiture *Materials and finishes*

### 1 contenitori *cabinets*

**materiale:** legno laccato o in essenza  
**material:** lacquer or wooden finish

**laccature** *lacquers*



**essenze** *wooden finishes*



### 3 bordo specchi *mirror body*

**materiale:** acciaio  
**material:** steel

**laccature** *lacquers*



## Esempi di composizione

*Composition examples*

50 x 100

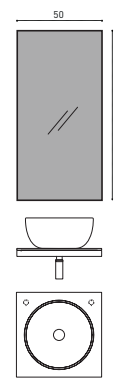

70 x 100

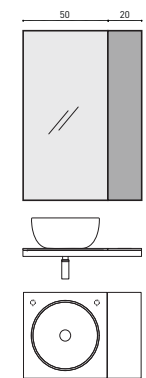

120 x 100

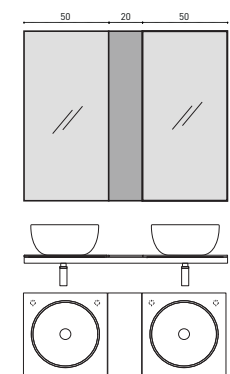
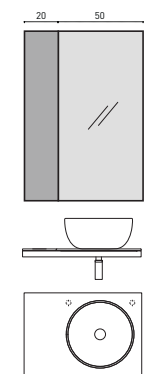
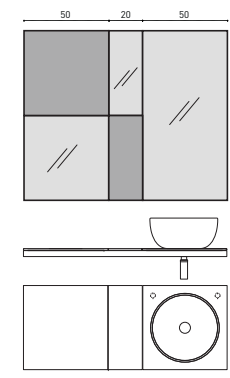

### Legenda



## Infinite possibilità di personalizzazione

*Infinite customized solutions*

esempi\_examples



1



2



3

1 lavabo/washbasin Basalto  
piano/top Basalto  
struttura/framework Nero Matt  
specchio/mirror

2 lavabo/washbasin Avena  
piano/top Avena  
struttura/framework Nero Matt  
specchio/mirror

3 lavabo/washbasin Lino  
piano/top Lino  
struttura/framework Nero Matt  
specchio/mirror

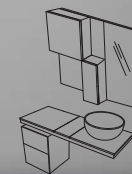

lavabo/washbasin Talco  
piano/top Talco  
cassettera/drawers Rovere Nero  
struttura/framework Nero Matt  
specchi/mirrors  
contenitori/cabinets Rovere Nero

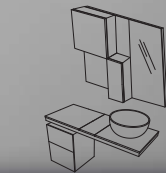

lavabo/washbasin Talco  
 piano/top Brina  
 cassettiera/drawers Rovere Nero  
 strutturale/framework Nero Matt  
 specchi/mirrors  
 contenitori/cabinets Rovere Nero

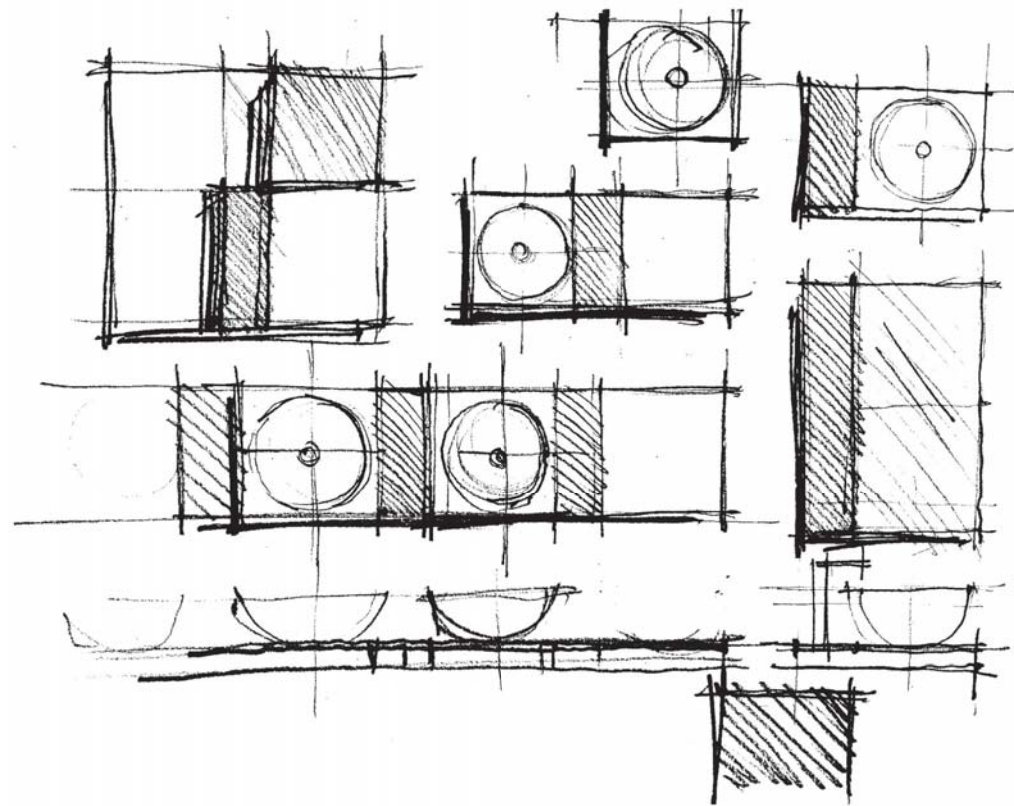

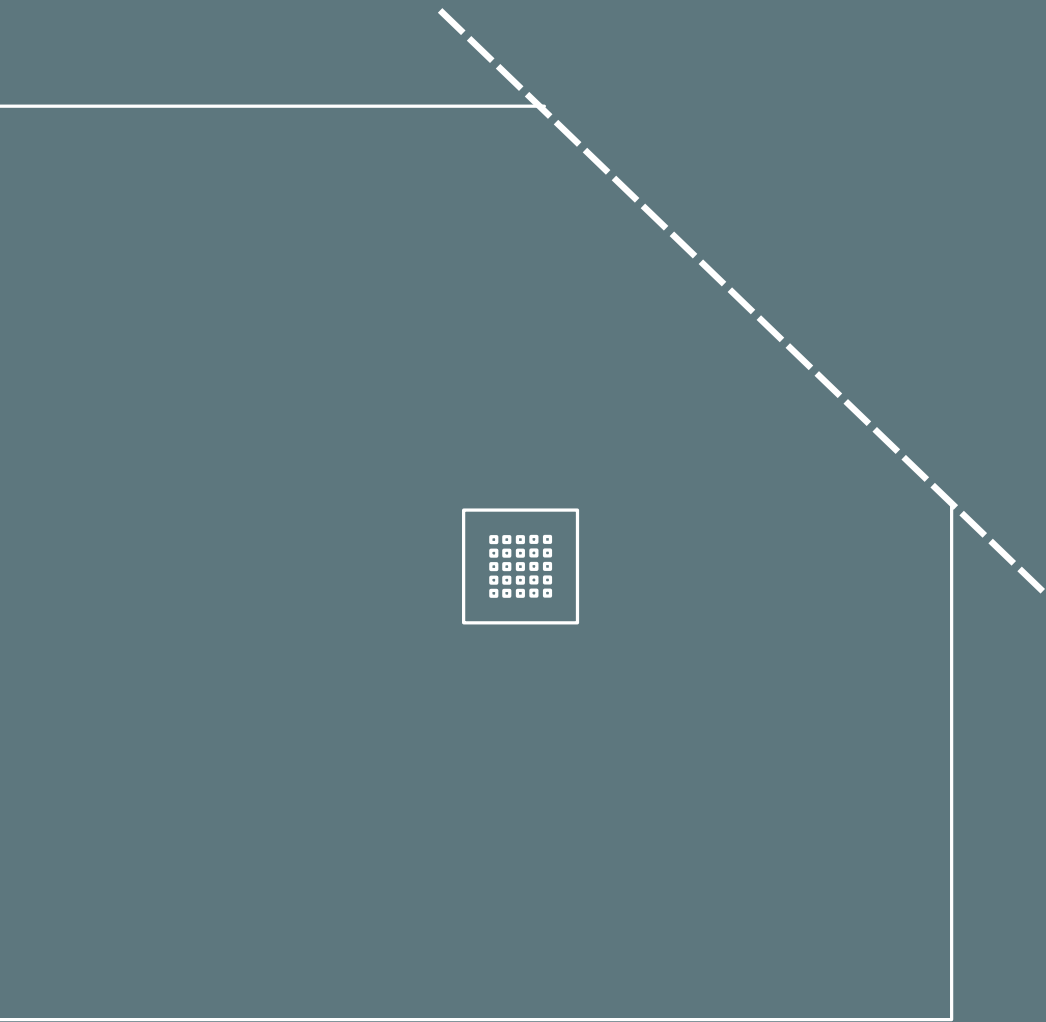

piatto doccia  
**Infinito**  
shower tray  
Infinito

“L'unico limite è la  
fantasia”

*“As boundless as  
imagination”*



## La rivoluzione del piatto doccia. Una ricerca durata oltre 3 anni

Shower tray  
revolution.  
Over 3 years of  
research

Ceramica Cielo presenta Infinito, la nuova gamma di piatti doccia in ceramica altezza 3 cm, un progetto innovativo e rivoluzionario nel mondo della doccia. L'utilizzo di materiale ceramico di alta qualità, dimensioni extra large, superfici inedite, spessori ridotti e ampia gamma di formati standard o personalizzabili a misura, costituiscono il carattere rivoluzionario del progetto **Infinito**, portando la Ceramica oltre i limiti finora esplorati.

*Ceramica Cielo is introducing Infinito, a new line of ceramic shower trays, 3 cm thick, a groundbreaking, innovative design for showers. Infinito design's groundbreaking features include its use of top-quality ceramic material, its extra large size, extra thinness, and uncommon surfaces, in a wide array of standard and customizable sizes. The design takes ceramic past new frontiers.*



piatto doccia in ceramica  
ceramic shower tray  
finitura / finish Talco







**H3 Infinito.**  
**Solo 3 centimetri di**  
**ceramica**  
Just 3 centimeters of  
ceramic

Cielo, attraverso un lungo processo di ricerca e sviluppo, è riuscita a realizzare un prodotto ceramico innovativo dallo spessore extra slim di soli 3 centimetri. La riduzione dello spessore, consente un risparmio di materia prima e di peso a vantaggio di una maggiore manovrabilità in fase di lavorazione e trasporto, ed un minor impatto ambientale.

*Through long research and development Cielo managed to create an innovative ceramic product, extra slim, only 3 centimeters thick. The thinness saves raw material and reduces its weight, making it easier to handle during treatment and transport, and reducing its environmental impact.*

25 misure standard  
standard sizes

20 diverse colorazioni  
different finishes

molteplici possibilità di tagli su misura  
many custom cutting options

infinite

possibilità di composizione  
composition options

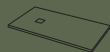
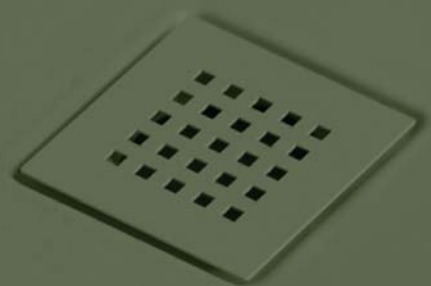

piatto doccia in ceramica  
ceramic shower tray  
finitura / finish Agave

## 25 misure standard + infinite su misura

25 standard sizes + infinite custom sizes

In questa pagina trovate tutte le misure standard disponibili, da cui si può ricavare una infinità di nuovi formati con il taglio a misura.

Here you can see all available standard sizes, from which you can realize an infinite number of new sizes through custom cutting.

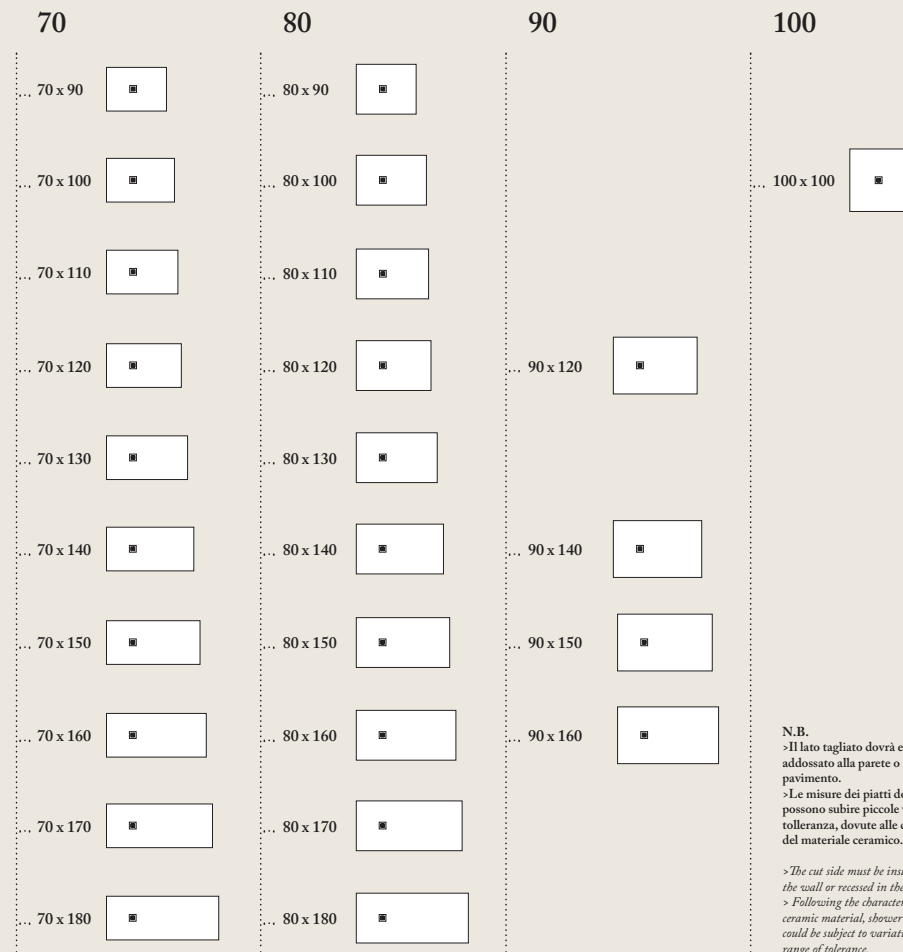

N.B.  
> Il lato tagliato dovrà essere addossato alla parete o incassato al pavimento.  
> Le misure dei piatti doccia possono subire piccole variazioni in tolleranza, dovute alle caratteristiche del materiale ceramico.

> The cut side must be installed against the wall or recessed in the floor.  
> Following the characteristic of ceramic material, shower trays' sizes could be subject to variations in a small range of tolerance.

# Una gamma di finiture unica al mondo

*A range of finishes uniques in the world*

Tutti i piatti doccia Infinito possono avere le seguenti finiture  
*All available finishes for Infinito shower trays collection*

## Le Terre di Cielo



I toni delle finiture sono sempre da considerarsi indicativi. Sono nella norma infatti lievi differenze di tonalità degli stessi.  
*The nuances of shown colors should always be considered approximated. Some slight color differences could be possible.*



# Extrà Ceramic

La nuova ceramica che diventa su misura e si adatta ai tuoi spazi.

A new ceramic material that you can customize to suit your spaces.

Grazie a speciali materie prime e tecniche di lavorazione particolari abbiamo realizzato una ceramica super sottile. Il risultato è un prodotto che esalta il design, la funzionalità e con un peso minore.

*We have developed an ultra-thin ceramic by using special materials and processing techniques. The result raises design and functionality up a notch while lowering weight.*

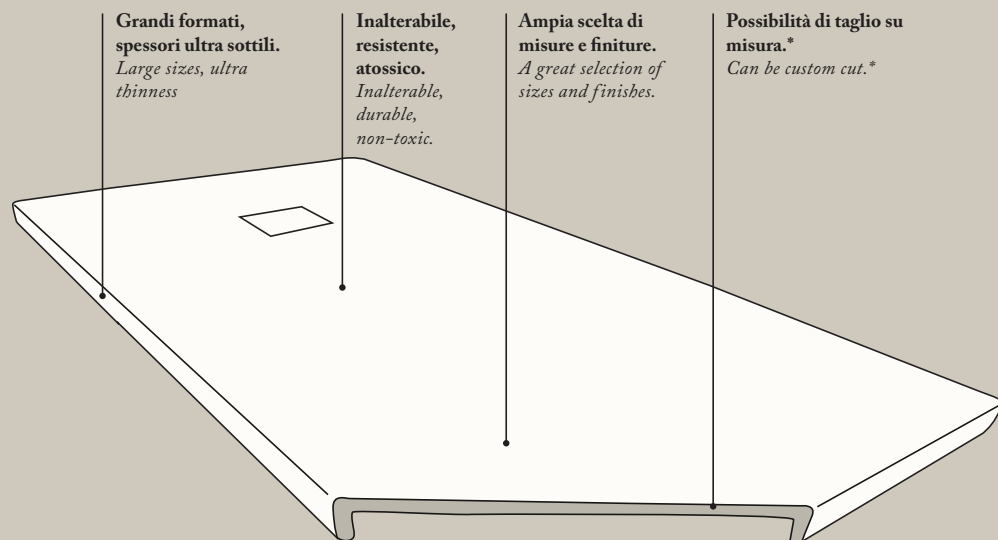

\* N.B: il lato tagliato dovrà essere addossato alla parete o incassato al pavimento.

\* N.B: The cut side must be installed against the wall or recessed in the floor.

## Perchè scegliere il nuovo piatto doccia H3 Infinito?

Why choose the new H3 Infinito shower tray?

E' realizzato in Ceramica, il materiale più resistente ed igienico presente sul mercato. La ceramica è il materiale nobile per eccellenza, uno materiali più antichi che l'uomo abbia mai conosciuto. Questo permette di avere un prodotto con caratteristiche ineguagliabili ed inalterabili nel tempo.

*It is made of ceramic, the strongest, most hygienic material available on the market. Ceramic is a noble material in the true sense of the word and among the longest known to humankind. This material gives products peerless qualities that stay true with the passing of time.*

## LA NUOVA DIMENSIONE DELLA CERAMICA THE NEW CERAMIC DIMENSION

### Ceramica di alta qualità High quality ceramic material

Una ceramica di nuova generazione cotta ad oltre 1200°, con spessori ridotti, in grado di mantenere inalterate nel tempo le proprie caratteristiche.  
*A new generation of ceramic, fired at over 1,200° Celsius, ultra thin, maintaining its characteristics unaltered over time.*



### Basso spessore Thin

Lo spessore di ingombro è di soli 3 cm, che equivale anche ad un minor uso di materia prima, a salvaguardia dell'ambiente.  
*Its overall thickness is only 3 cm, which means that less raw material needs to be used, a plus for the environment.*



### Resistente agli acidi Acids resistant

Gli smalti Speciali e di alta qualità utilizzati da CIELO garantiscono una protezione assoluta dall'attacco agli acidi.  
*Cielo uses special high-quality glazes that protect completely the material against acid.*



### Antimacchia Stain-proof

La speciale smaltatura rende la superficie impermeabile e inattaccabile alle macchie.  
*The special glazing makes the surface waterproof and stain-proof.*



### Leggero Lightweight

Minor peso dunque maggiore manovrabilità in fase di lavorazione e trasporto.  
*Low weight, making it easier to handle during processing and transport.*



### esempi examples

70 x 160 = 39,5 Kg  
80 x 160 = 45,5 Kg  
80 x 140 = 42,5 Kg  
90 x 160 = 51 Kg

### Colorato Colorful

I piatti doccia Infinito sono realizzabili nell'intera gamma di colori e finiture di Cielo.  
*Infinito shower trays are available in Cielo's full range of colors and finishes.*



**Un prodotto  
trasversale e  
modulare, unico  
nelle dimensioni,  
negli spessori e  
nelle finiture.  
Qualità superiore  
sia nella bellezza  
della superficie che  
nella sua durata**  
Multi-use and  
modular. Unique  
dimensions, thinness,  
and finishes. Superior  
quality, both for the  
beauty of its surfaces  
and its durability.



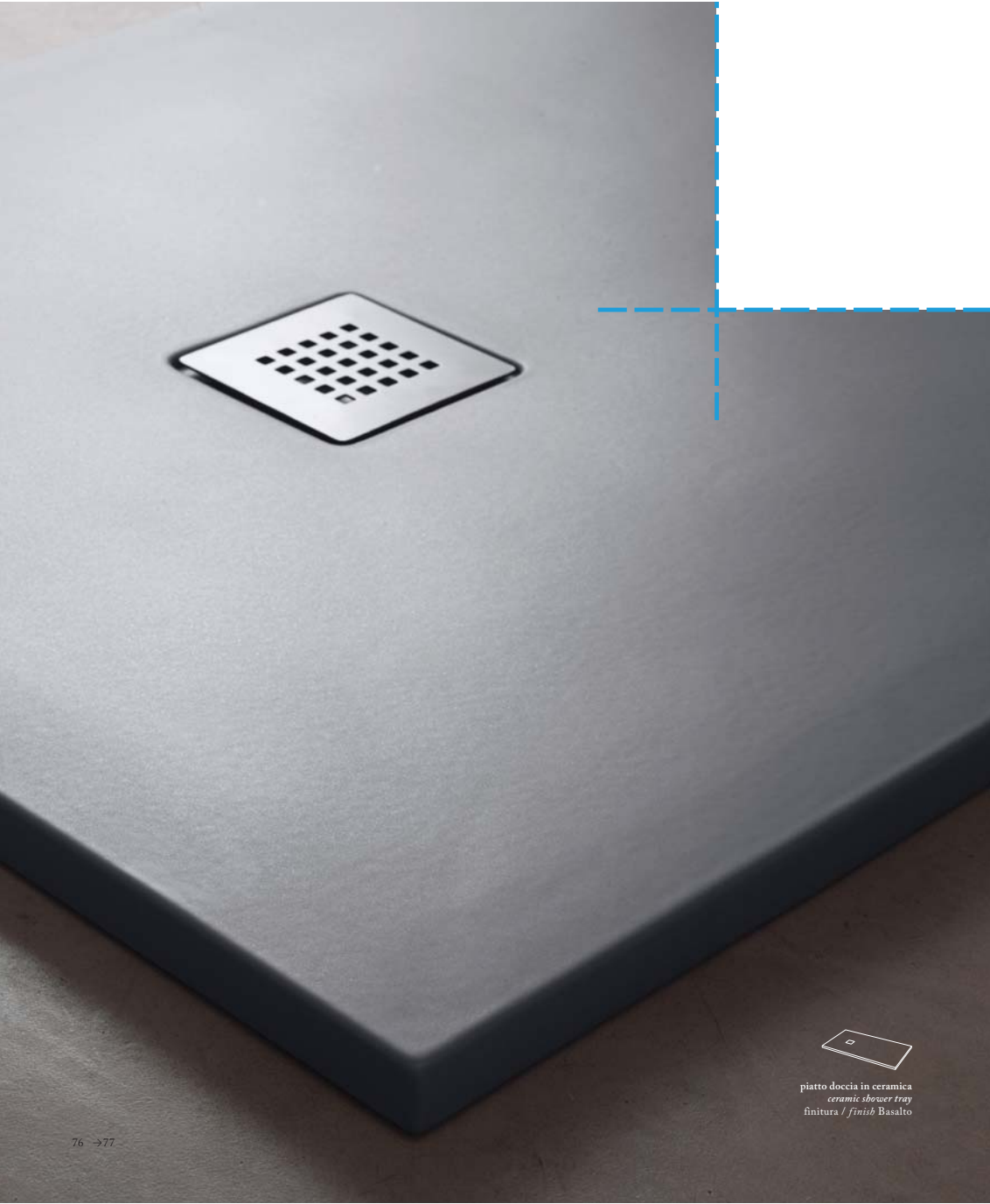

## CERAMICA SU MISURA: LA RIVOLUZIONE DEL PIATTO DOCCIA

## CUSTOMIZED CERAMIC: A SHOWER TRAY REVOLUTION

DX

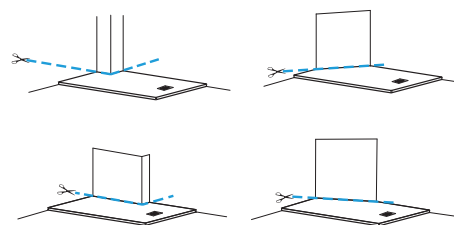

SX

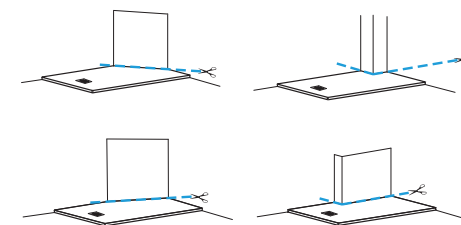

DX

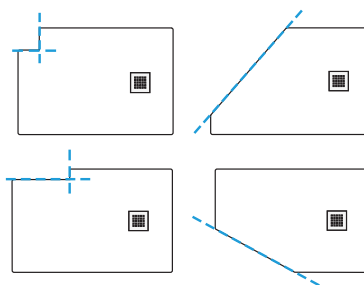

SX

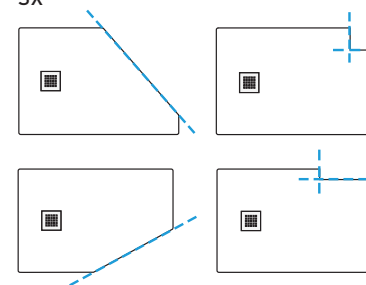

piatto doccia in ceramica  
ceramic shower tray  
finitura / finish Basalto

Caratteristica principale della collezione infinito è la possibilità di personalizzazione scegliendo tra le molteplici finiture e formati standard o a misura. Tutti i piatti doccia della collezione si possono tagliare a misura. La misura standard massima è 180 x 90 cm e la minima è 90 x 70. Non sono possibili tagli curvi. Il lato tagliato rimarrà non smaltato e dovrà essere addossato alla parete o incassato al pavimento.

*The key feature of the Infinito collection is the option of customizing it starting from many finishes and sizes. All shower trays of this collection may be custom cut. The bigger standard size is 180x90 cm, and the smaller is 90 x 70 cm. Curved cuts are not possible. The cut side will not be glazed so it must be installed against the wall or recessed in the floor.*



Ogni pezzo viene lavorato, plasmato e rifinito dalle mani esperte di artigiani che realizzano un pezzo di design, unico e prezioso.

*Each piece is worked, shaped and finished by the expert hands of craftspeople to create unique design pieces of peerless quality.*





## Le Terre di Cielo

L'invenzione del  
colore  
The invention of  
colour

“Tra tutte le qualità, il  
colore è quella di cui è  
più difficile parlare”

*“Above all characteristics,  
color is the most difficult  
to talk about”*

Aristotele, *Sui colori*

# Le Terre di Cielo





## La natura come matrice cromatica Nature as chromatic matrix

“Colori e suoni appartengono alla natura” scriveva Goethe nella sua *Teoria dei colori*, “[...] essi sono fenomeni naturali [...] sono il linguaggio stesso della natura”.

La natura è colore, gli elementi vegetali e minerali, le rocce, le piante, gli animali, si contraddistinguono in base al loro colore e alla loro conformazione. Il legame intrinseco tra colore e natura deve guidare indissolubilmente, secondo Goethe, l’atteggiamento dell’uomo nei confronti dei colori, che partecipano attivamente alle esperienze sensoriali attraverso una propria forma di comunicazione.

*“Colours and sounds belong to nature” wrote Goethe in his Theory of colours, “[...] they are natural phenomena [...] they are the very language of nature”.*

*Nature is colour; vegetal and mineral elements, stones, plants and animals are characterized on the basis of their colours and conformations.*

*According to Goethe, the intrinsic bond between colour and nature must indissolubly guide Man’s attitude to colour, which plays an active role in sensorial experiences through an own form of communication.*

**«colori e suoni appartengono alla natura [...] sono il linguaggio stesso della natura \_colours and sounds belong to nature [...] they are the very language of nature»**

Già nell’antichità l’opinione più diffusa sosteneva che i colori incorporati dell’arcobaleno si sostanziasse in quelli della natura, in particolare nelle pietre preziose e nei loro sostituti, smalti e paste vitree. Alla componente naturalistica del colore si rifanno anche molti dei nomi che questi hanno assunto nel corso dei secoli mostrando, una volta di più, il riferimento naturale di ciascun cromatismo.

*Already in antiquity it was widely held that the ethereal colours of the rainbow assumed tangible form in those of nature, especially in precious stones and their substitutes, glass glazes and paste. Many of the names that colours have been given in the course of the centuries can also be retraced to their naturalistic component: another conformation of the natural associations of each chromatic shade.*



*Lavagna*

*Basalto*

*Muschio*

*Agave*



*Cacao*

*Cemento*

*Avena*

*Polvere*

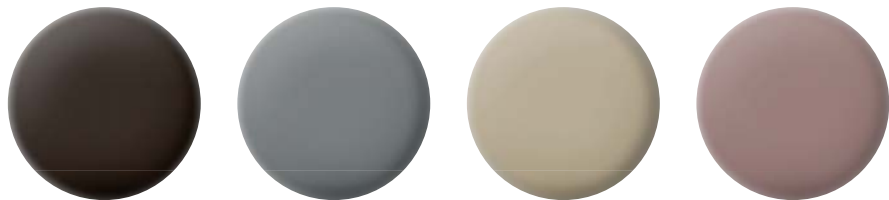

*Fango*

*Brina*

*Lino*

*Cipria*



*Arenaria*

*Pomice*

*Talco*

*Canapa*

## Le Terre di Cielo 2° edizione 2013/2016 2° edition 2013/2016

**Cielo, prima azienda a realizzare colori ceramici unici ed innovativi, dopo lo straordinario successo arricchisce la gamma con inedite nuances.**

*The first company to have made unique, innovative ceramic colors, Cielo is following this extraordinary success and introducing new nuances to the line.*

## Lavagna

Il grigio-nero profondo della roccia argillosa, si affianca alla sottile asprezza della sua superficie sfaldabile.

*The deep gray-black of this clay-based rock is paired by the subtle roughness of its foliated surface.*

Parole, colori, luci, suoni, pietra, legno, bronzo appartengono all'artista vivente. Appartengono a chiunque sappia usarli.

*Words, colours, light, sounds, stone, wood and bronze belong to the living artist. They belong to anyone who knows how to use them.*

William Seward Burroughs, *Les voteurs*, 1994



bacinella da appoggio Shui Ø45  
Shui on top bowl Ø45  
Ø45 x 12h - SFBA45  
finitura / finish Lavagna

## Talco

Scaglie e piccoli cristalli minerali si trasformano in morbida polvere di un bianco latte contaminato da punte brunastre.

*Mineral flakes and small crystals turn into a soft, milky white powder contaminated by brownish points.*



bidet sospeso Le Giare con bacino reverso  
*Le Giare reverse shape wall-hung bidet*  
37 x 55 x 33,5h - LGBSREV  
finitura / finish Talco



vaso sospeso Le Giare  
*Le Giare wall-hung wc*  
37 x 55 x 37,5h - LGV5  
finitura / finish Talco

## Brina

L'aspetto candido della brina si confonde con la sua superficie cristallina e granulosa, fatta di scaglie di morbido ghiaccio.

*The whiteness of the frost is hard to distinguish from its crystalline and granular surface, made from soft ice flakes.*



vaso a terra Smile 53  
*Smile back to wall wc 53*  
34 x 53 x h42 - SMVAS  
finiture / finish Brina



bidet a terra Smile 53  
*Smile back to wall bidet 53*  
34 x 53 x h42 - SMBID  
finiture / finish Brina

## *Avena*

Le delicate cromaticità dei fiocchi d'avena giocate su toni caldi e dorati, suggeriscono sensazioni di leggerezza e luminosità.

*The subdued tones of oat are infused with touches of warm, golden hues for an impression of lightweight luminosity.*



lavabo da appoggio L.e. Giare 60  
*Le Giare on top washbasin 60*  
60 x 45 x 14,5h - LGLA60  
finitura / finish Avena





 bacinella da appoggio Shui Ø40  
*Shui on top basin Ø40*  
Ø40 x 18h - SHBA40  
finitura / *finish* Brina





## *Arenaria*

L'origine sedimentaria dell'arenaria unisce le tonalità del grigio in un unico, elegante colore, identificativo della sua natura litica.

*The sedimentary origin of sandstone combines different shades of grey in a single, elegant colour which bears witness to its lithic nature.*



orinatoio sospeso Ball  
wall-hung urinal Ball  
66 x 30 x 70h - ORBL  
finitura / finish Arenaria





lavabo Shui Comfort quadrato 40  
Shui Comfort square washbasin 40  
40 x 40 x h12,5 - SHCOLAQ40  
finitura / finish Polvere



Il colore è un tasto,  
l'occhio il martelletto  
che lo colpisce, l'anima  
lo strumento dalle mille  
corde.

*Colour is a key, the eye  
the hammer that strikes  
it, the soul an instrument  
with a thousand chords.*

Vasilij Kandinskij, *Della spiritualità dell'arte*, 1941

### *Polvere...di Cielo*

Dal ciano al violetto, dalle  
sfumature più fredde del  
grigio all'azzurro del cielo.  
Una nuance raffinata in piena  
armonia con la natura.

*From cyan to violet, with  
cooler overtones of gray  
and sky blue. A refined hue  
in complete harmony with  
nature.*



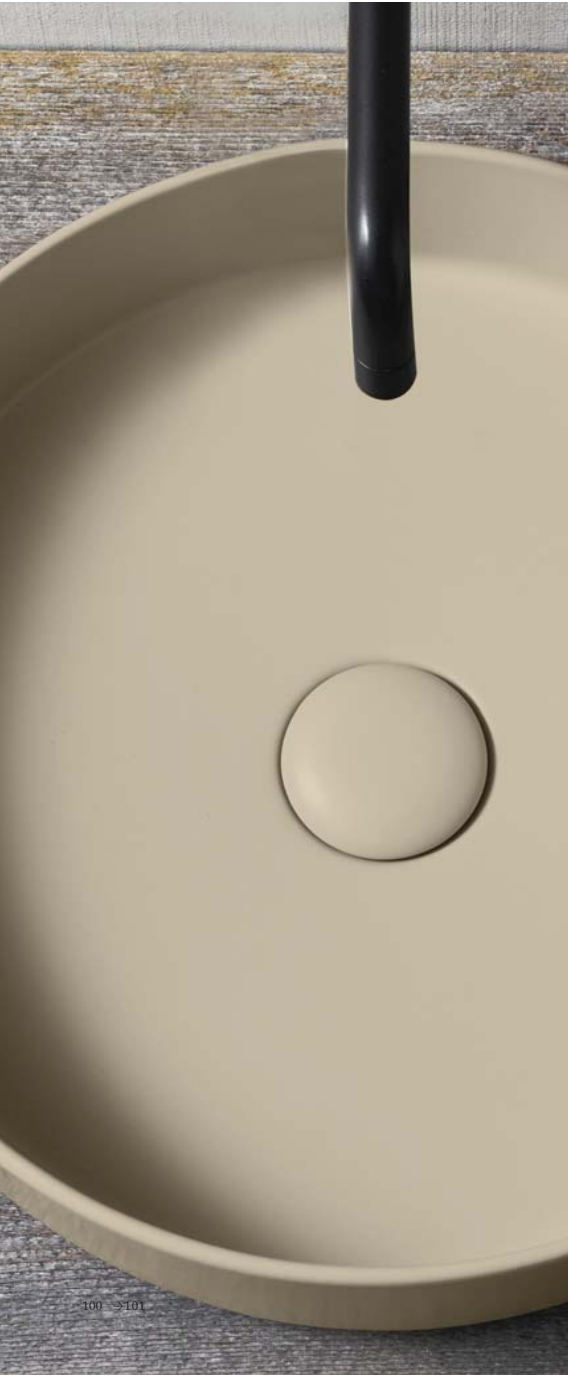

### *Lino*

L'aspetto fresco e morbido del lino si associa alla sua struttura resistente, attenuata da toni chiari e delicati.

*Flax's cool, fresh appearance is paired by its sturdy structure, softened by light, gentle hues.*



lavabo Shui Comfort tondo 40  
shui Comfort round washbasin 40  
40 x 40 x h12,5 - SHCOLAT40  
finitura / finish Lino

## Pomice

Il grigio tenue della pietra pomice si associa alla sottile scabrosità della sua superficie porosa.

*The light grey colour of the pumice stone is associated with the subtle roughness of its porous surface.*



bidet a terra Le Giare  
*Le Giare back to wall bidet*  
37 x 55 x 42,5h - LGB1  
finitura / finish Pomice



vaso a terra Le Giare  
*Le Giare back to wall wc*  
37 x 55 x 42,5h - LGVA  
finitura / finish Pomice



vaso sospeso Fluid  
*Fluid wall-hung wc*  
37 x 53 x 37h - FLVS  
finitura / finish Arenaria



bidet sospeso Fluid  
*Fluid wall-hung bidet*  
37 x 53 x 37h - FLBS  
finitura / finish Arenaria



bacinella da appoggio Shui Ø40  
Shui on top bowl Ø40  
Ø40 x 18h - SFBA.40  
finitura / finish Fango

## *Fango*

Terra e polvere intrise  
d'acqua danno vita ad un  
impasto dai toni neutri,  
in cui i marroni e i grigi si  
uniscono in un' unica nuance,  
accattivante e sensuale.

*Earth and dust mix with  
water to create a mixture of  
neutral hues, with browns  
and grays merging in an  
alluringly sensual tone.*



## Basalto

L'origine vulcanica del basalto definisce tonalità scure tendenti al blu-oceano, un colore tanto profondo quanto vicino alla superficie del mare e della notte.

*It is the volcanic origin of basalt that gives it its distinctive dark nuances tending to sea blue, a colour that is as profound as it is close to the surface of the ocean and the night.*



vaso sospeso Shui Comfort  
*Shui comfort wall-hung wc*  
37,5 x 55 x h37 - SHCOVS  
finitura / finish Basalto



bidet sospeso Shui Comfort  
*Shui Comfort wall-hung bidet*  
37,5 x 55 x h37 - SHCOBS  
finitura / finish Basalto



## Cemento

La durissima 'pietra' artificiale, generata da una morbida pasta di polvere e acqua, assume un elegante colore grigio intenso che si fonde con pigmenti testa di moro.

*This extra-hard artificial 'stone', made out of a soft paste of powder and water, takes on an intense gray hue blending with dark brown tone.*



bacinella da appoggio Shui Ø40  
*Shui on top bowl Ø40*  
Ø40 x 18h - SHBA40  
finitura / finish Cemento



bacinella da appoggio Shui Ø40  
*Shui on top bowl Ø40*  
Ø40 x 18h - SHBA40  
finitura / finish Cemento



bacinella da appoggio Shui 045  
Shui on top bowl 045  
045 x 12h - SHBA45  
finitura / finish Muschio

## *Muschio*

Il verde del muschio di sottobosco evoca sensazioni primordiali associate alla morbida tattilità della sua superficie.

*The intense green of the moss found in forest undergrowth evokes primordial sensations associated with the tactile softness of its surface.*

I colori sono i veri  
abitanti dello spazio.  
La linea non fa che  
viaggiarvi attraverso  
e percorrerlo; essa  
passa soltanto.

*Colours are the true  
inhabitants of space.  
The line merely travels  
through it, crossing it.*

Yves Klein, *Zero 1*, 1958



lavabo Shui Comfort 60 x 40  
*Shui Comfort washbasin 60 x 40*  
60 x 40 x 12,5h - SHCOLAR60  
finitura / finish Brina



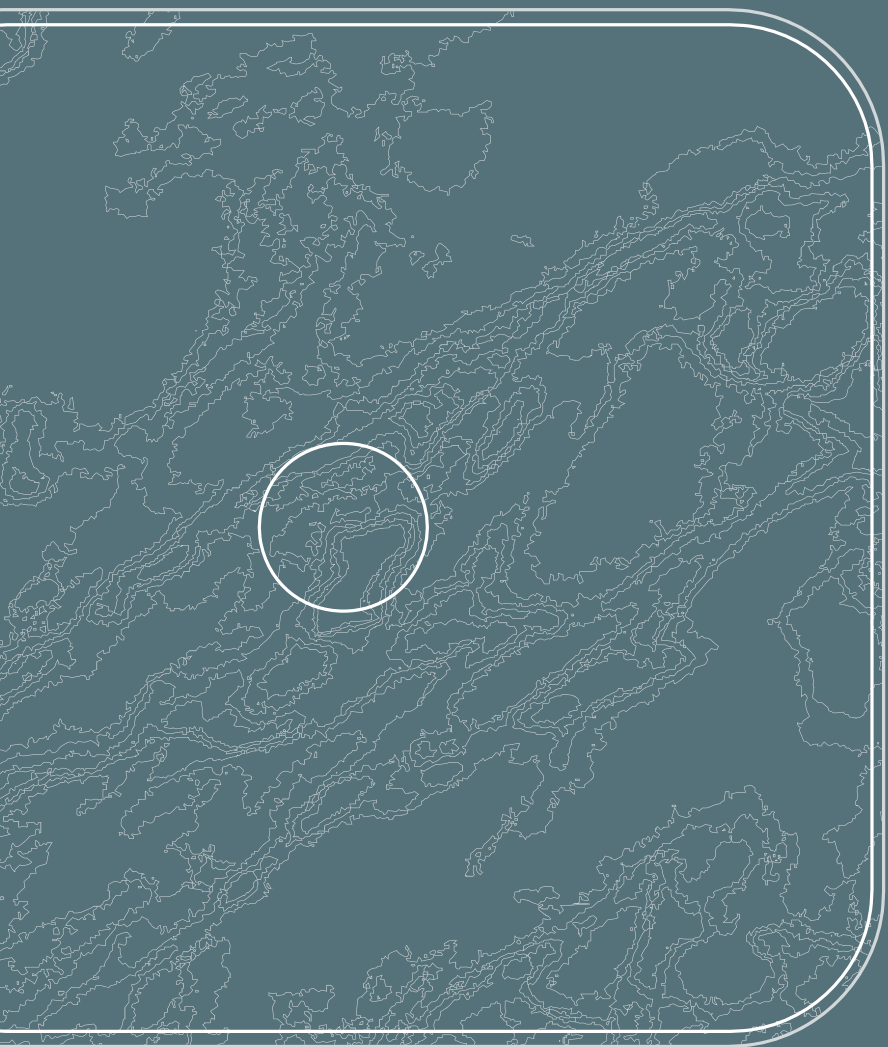

## Le Pietre

“Un progetto Tailor-made  
che conduce la ceramica verso  
nuovi inesplorati orizzonti”

*“A tailor-made project to bring  
ceramic to unexplored horizons”*

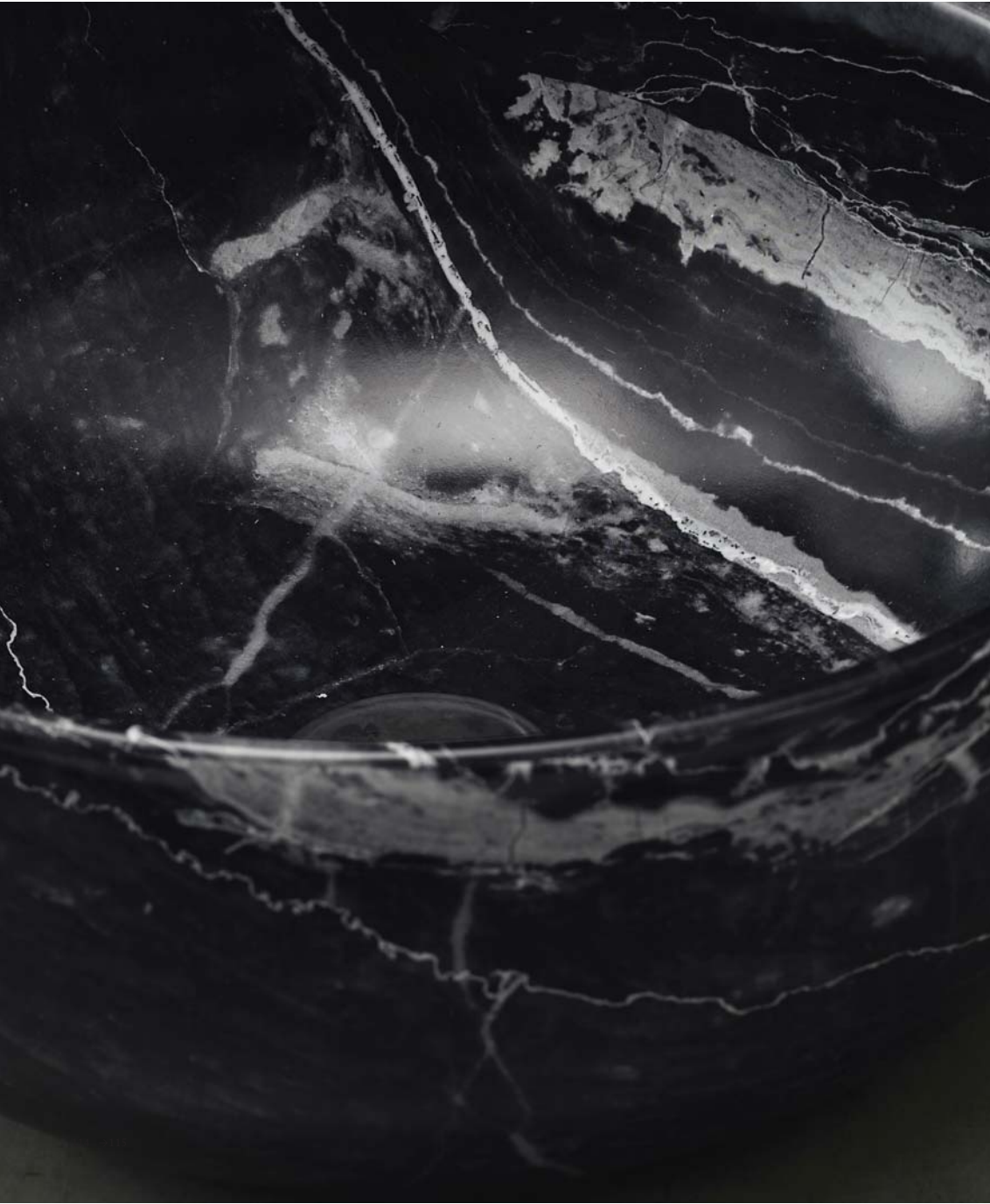

## Quando la ceramica "cambia pelle" Ceramic's metamorphosis

La versatilità del materiale ceramico unita alla sperimentazione di nuove finiture e all'incontro con altri materiali come pietre o marmi, dà vita ad un prodotto sofisticato, prezioso, unico, che conserva in sé i valori dell'artigianalità appartenenti ad un'epoca passata, ma dal carattere elegante ed estremamente innovativo.

*Ceramic's versatility as a material, the use of innovative new finishes, and relationships forged with other materials like stone and marble are the source of a uniquely sophisticated beautiful product true to the values of craftsmanship from a bygone era while being highly innovative and elegant.*

**«Troverai più  
nei boschi che nei libri.  
Gli alberi e le pietre ti  
insegneranno cose che  
nessun maestro ti dirà.  
You will find something  
far greater in the woods  
than in books. Stones  
and trees will teach  
you that which you  
cannot learn from the  
masters.»**

**Bernardo Di Clairvaux**



La Ceramica: il materiale più versatile  
che l'uomo abbia mai conosciuto

*Ceramic: the most versatile material  
that man has ever known.*



## Carrara Statuario

La colorazione bianco avorio e la sua particolare tessitura cristallina vengono evocate da una grande omogeneità e venature ridottissime. È il marmo che fin dall'antichità è stato utilizzato per le sculture più pregiate.

*This marble - since the time of antiquity - has been used for the finest sculptures. Its ivory white color and unique crystalline grain are suggested by great evenness and especially small veins.*



lavabo Shui Comfort quadrato 40  
Shui Comfort square washbasin 40  
40 x 40 x h12,5 - SHCOLAQ40  
finitura / finish Carrara Statuario

## Finiture disponibili Available finishes



Carrara Statuario

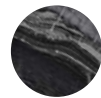

Breccia Arabescata

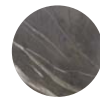

Grey Stone

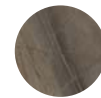

Breccia Paradiso



Nero Marquina

## Lavabi disponibili nella collezione Le Pietre Washbasins available in the Le Pietre collection



lavabo Shui Comfort rettangolare 60 x 40  
Shui Comfort rectangular washbasin 60 x 40  
60 x 40 x h12,5 - SHCOLAR60



lavabo Shui Comfort ovale 60 x 38  
Shui Comfort oval washbasin 60 x 38  
60 x 38 x h12,5 - SHCOLAO60



lavabo Shui Comfort quadrato 40  
Shui Comfort square washbasin 40  
40 x 40 x h12,5 - SHCOLAQ40



lavabo Shui Comfort tondo 40  
Shui Comfort round washbasin 40  
40 x 40 x h12,5 - SHCOLAT40



lavabo Le Giare da appoggio 60  
Le Giare on top washbasin 60  
60 x 45 x h14,5 - LGLA60



bacinella d'appoggio Shui senza troppo pieno Ø45 - Shui on top bowl without overflow Ø45 - ø45 x h12 - SHBA45



bacinella d'appoggio Shui senza troppo pieno Ø40 - Shui on top bowl without overflow Ø40 - ø40 x h18 - SHBA40

I toni delle finiture sono sempre da considerarsi indicativi. Sono nella norma infatti lievi differenze di tonalità degli stessi.  
*The nuances of shown colors should always be considered approximated. Some slight color differences could be possible.*



bacinella da appoggio Shui Ø40  
*Shui on top bowl Ø40*  
Ø40 x 18h - SHBA40  
finitura / *finish* Breccia Arabescata



### *Breccia Arabescata*

Di colore nero intenso, con delle venature bianche che disegnano una trama simile ad un arabesco. Particolarmente bello per la sua varietà cromatica che lo rende unico ed elegante.

*An intense black, its white veins form a pattern not unlike an arabesque. Uniquely beautiful for its varied colorations that render it unique and elegant.*



bacinella da appoggio Shui Ø45  
*Shui on top bowl Ø45*  
Ø45 x 12h - SHBA45  
finitura / *finish* Breccia Arabescata



## Grey Stone

I toni caldi e profondi che vanno dal grigio-antracite al marrone, colpiti da delicate venature bianche, evocano una bellezza senza tempo, conservata nelle pietre naturali.

*Deep warm hues range from gray-charcoal to brown, shot through with delicate white veins, expressing the timeless beauty that natural stones hold within.*



lavabo Le Giare da appoggio 60  
Le Giare on top washbasin 60  
60 x 45 x 14,5h - LGLA60  
finitura / finish Grey Stone



lavabo Shui Comfort quadrato 40  
*Shui Comfort square washbasin 40*  
40 x 40 x h12,5 - SHCOLAQ40  
finitura / finish Breccia Paradiso



### *Breccia Paradiso*

Dal marrone scuro al nocciola, presenta accenti di grigio e venature di color crema, leggermente dorate. È un marmo dai toni caldi e dalla struttura compatta.

*From dark brown to hazelnut, it features gray highlights and cream-colored, slightly golden veins. This marble has warm hues and a compact structure.*



bacinella da appoggio Shui Ø40  
Shui on top bowl Ø40  
Ø40 x 18h - SHBA40  
finitura / finish Nero Marquina



## Nero Marquina

È un marmo a grana fine di colore nero profondo, picchiettato da resti di fossili bianchi e percorso da venature bianche più evidenti, che occasionalmente virano anche verso il verde e l'ocra.

*Deep black, fine grained marble, it is flecked with the white of fossil remains and shot through with more apparent white veins, at points tending towards green and ochre.*



lavabo Shui Comfort tondo 40  
shui Comfort round washbasin 40  
40 x 40 x h12,5 - SHCOLAT40  
finitura / finish Nero Marquina





Cura del dettaglio, materiali di  
pregio, sapienza artigianale.

*Meticulous details, superior materials,  
fine craftsmanship*

Aprile 2016

fotolito e stampa  
*TAP Grafiche - Poggibonsi*

## **Ceramica Cielo Spa**

Via Falerina km 7800

01034 - Fabrica di Roma (VT)

t +39 0761 56701 / f +39 0761 540363

[info@ceramicacielo.it](mailto:info@ceramicacielo.it)

[www.ceramicacielo.it](http://www.ceramicacielo.it)

## **Spazio Cielo**

Via Pontaccio 6

20121 - Milano Italy

t +39 0239661165