

CATALOGO GENERALE_PARTE PRIMA 1
0 1 8

SANITARI *SANITARY-WARE* _ **TOP** _ **LAVABI** *SINKS* _ **LAVABI FREESTANDING** *FREESTANDING SINKS* _ **VASCHE** *TUBS*

antoniolupi

bagnarsi ad arte_bathing with art

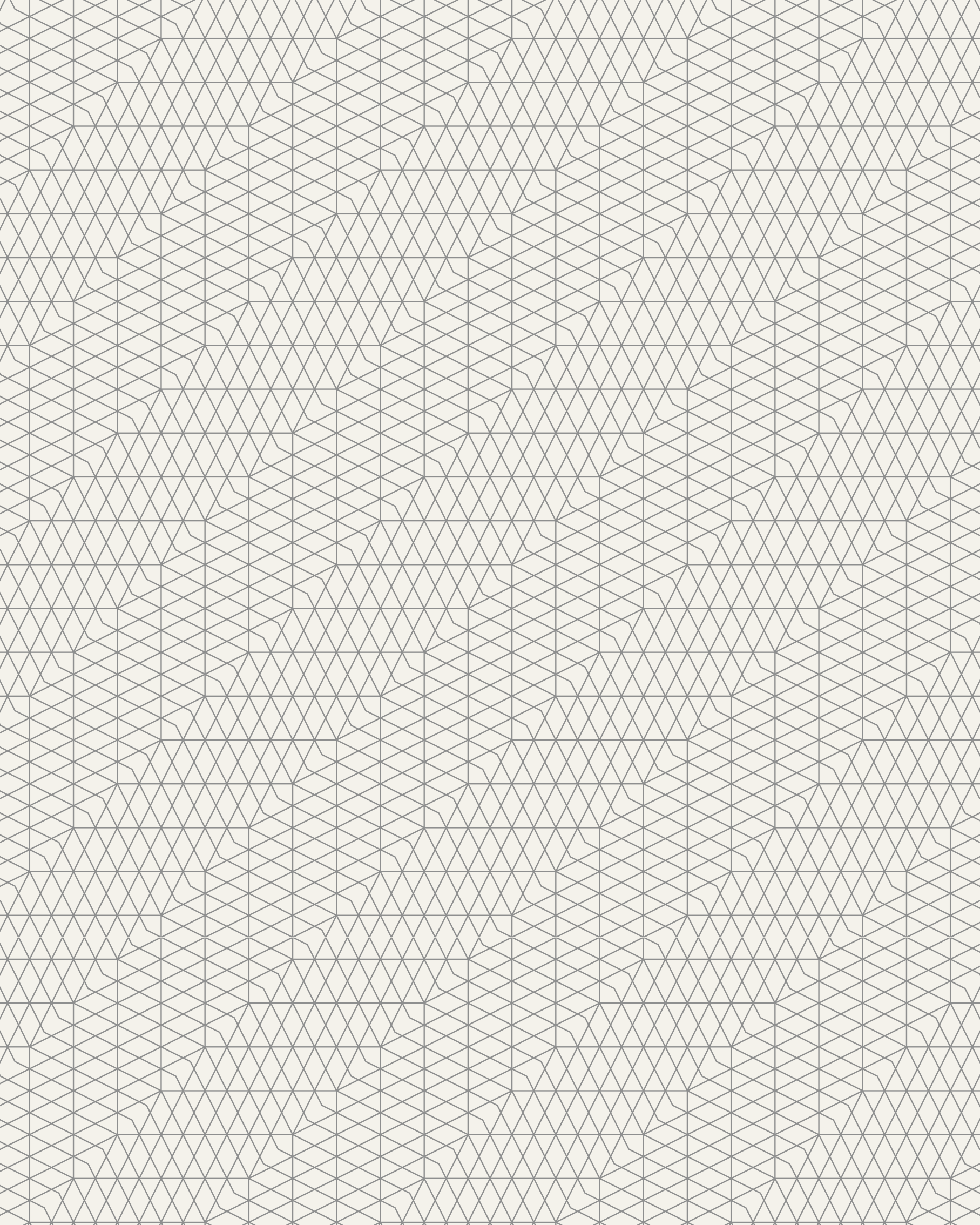

CATALOGO GENERALE_PARTE PRIMA
0 1 8

www.antoniolupi.it

Per essere costantemente informati su novità e prodotti in modo dettagliato, vi invitiamo a navigare nel nostro sito sempre aggiornato. Nell'area download potrete scaricare tutto il materiale tecnico ed informativo che vi necessita.

To constantly be up to date in a detailed manner on novelties and products please navigate through our website. In the download area you can find all the necessary technical information.



Scarica l'App su iTunes e Google Play per entrare nel mondo antoniolupi

Download the App on iTunes and Google Play to discover the world of antoniolupi

antoniolupi

bagnarsi ad arte_bathing with art



INDICE / INDEX

4 - 29
SANITARI / *SANITARY-WARE*

30 - 91
TOP / *TOPS*

92 - 271
LAVABI / *SINKS*

272 - 339
LAVABI / *SINKS*
FREESTANDING

340 - 431
VASCHE / *TUBS*



SANITARY / *SANITARY-WARE*

sanitary / sanitary-ware



CABO design Daniel Debiasi - Federico Sandri

Una forma scultorea fatta di superfici sinuose e continue, una silhouette raffinata che esalta le potenzialità del materiale ceramico ed esprime una sensazione di leggerezza sia nella versione sospesa che in quella a terra.

Cabo è la collezione di sanitari che associa estetica sofisticata e massima igiene, grazie all'assenza nel wc della brida tradizionale.

Il vaso in ceramica della collezione Cabo, utilizza il sistema LESS_RING che oltre a garantire una perfetta pulizia del volume interno e massima capacità di sciacquo, dona all'insieme un'immagine finale gradevole. Il movimento circolare consente di lavare in modo preciso e senza spruzzi tutta la superficie, contrariamente a quanto avveniva con i normali vasi con la brida, per un'igiene del 100%.

A sculptural form made of sinuous and continuous surfaces, a refined silhouette that enhances the potential of ceramic material and expresses a feeling of lightness available in both the suspended version and in the floor version.

Cabo is the collection of sanitary ware that combines sophisticated aesthetics and maximum hygiene thanks to the absence of the traditional toilet rim.

The ceramic water closet, from the Cabo collection, uses the LESS_RING system that ensures perfect internal cleaning and a maximum ability to rinse. The circular movement allows to wash in a precise manner and without splashing, contrary to what happens with standard water closets with a rim, to assure 100% hygiene.







SISTEMA "LESS_RING" / "LESS_RING" FLUSHING SYSTEM



Il vaso in ceramica della collezione Cabo, utilizza il sistema LESS_RING che oltre a garantire una perfetta pulizia del volume interno e massima capacità di sciacquo, dona all'insieme un'immagine finale gradevole. Il movimento circolare consente di lavare in modo preciso e senza spruzzi tutta la superficie, contrariamente a quanto avveniva con i normali vasi con la brida, per un'igiene del 100%.

The ceramic water closet, from the Cabo collection, uses the LESS_RING system that ensures perfect internal cleaning and a maximum ability to rinse. The circular movement allows to wash in a precise manner and without splashing, contrary to what happens with standard water closets with a rim, to assure 100% hygiene.

H	P	L	art.	
26	54	36,6	CABO1	Ceramica Lucida / High gloss Ceramic
26	54	36,6	CABO3	Ceramica Satinata / Satin Ceramic

Vaso in ceramica lucida o satinata, sospeso con scarico a parete e sistema senza brida, completo di sedile avvolgente FLAT con sistema di sganciamento rapido, realizzato in resina termoindurente con chiusura rallentata "soft-close".

High gloss or satin suspended ceramic water closet with wall drain and washdown rimless flushing, complete with seat and cover FLAT made of thermosetting resin, quick release system and soft closing hinges.

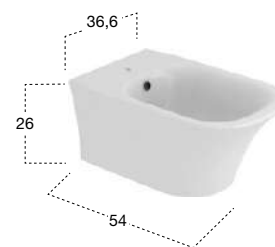

H	P	L	art.	
26	54	36,6	CAB02	Ceramica Lucida / High gloss Ceramic
26	54	36,6	CAB04	Ceramica Satinata / Satin Ceramic

Bidet monoforo in ceramica lucida o satinata, sospeso con scarico a parete.

High gloss or satin suspended ceramic bidet with wall drainage and single tap hole.

CABO



SISTEMA "LESS_RING" / "LESS_RING" FLUSHING SYSTEM



H	P	L	art.	
42	54	36,6	CAB021	Ceramica Lucida / High gloss Ceramic
42	54	36,6	CAB023	Ceramica Satinata / Satin Ceramic

Vaso in ceramica lucida o satinata, da terra con scarico a pavimento o a parete e sistema senza brida, completo di sedile avvolgente FLAT con sistema di sganciamento rapido, realizzato in resina termoindurente con chiusura rallentata "soft-close".

High gloss or satin freestanding ceramic water closet with floor or wall drain and washdown rimless flushing, complete with seat and cover FLAT made of thermosetting resin, quick release system and soft closing hinges.

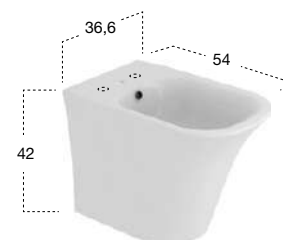
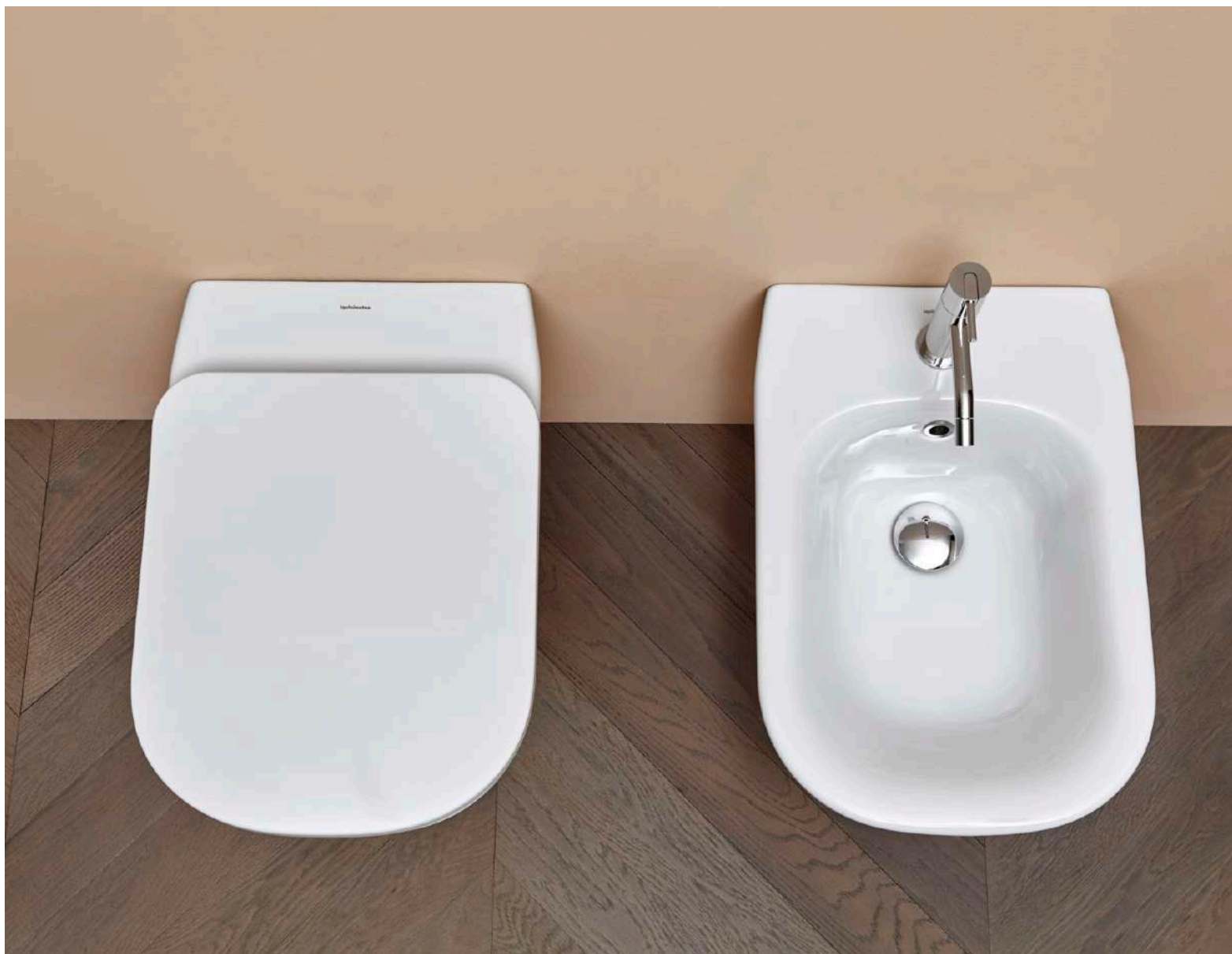

H	P	L	art.	
42	54	36,6	CAB022	Ceramica Lucida / High gloss Ceramic
42	54	36,6	CAB024	Ceramica Satinata / Satin Ceramic

Bidet monoforo in ceramica lucida o satinata, da terra con scarico a parete.

High gloss or satin freestanding ceramic bidet with wall drainage and single center tap hole.



Sedile con sistema di sganciamento rapido.

Seat and cover with quick release system.



Sedile con chiusura rallentata "soft-close".
Seat and cover with soft closing hinges.



KOMODO design AL Studio

Immagine pulita ed essenziale generata dalla sintesi organica di linee rette e superfici curve che si integrano dando vita a elementi compatti, dall'estetica contemporanea. Komodo è una collezione di sanitari realizzata in ceramica nella finitura lucida o satinata che comprende vaso sospeso con scarico a parete, completo di sedile avvolgente FLAT con sistema di sganciamento rapido, realizzato in resina termoindurente con chiusura rallentata "soft-close" e bidet monoforo sospeso, sempre con scarico a parete.

Clean essential image generated by the organic synthesis of straight lines and curved surfaces that integrate together creating compact elements from contemporary aesthetics. Komodo is a collection of suspended sanitary-ware made in glossy or matt ceramic complete with seat and cover FLAT made of thermosetting resin, quick release system and soft closing hinges and bidet with single centered tap hole.



KOMODO

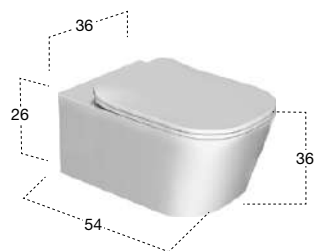

H	P	L	art.	
26	54	36	KOMODO1	Ceramica Lucida / High gloss Ceramic
26	54	36	KOMODO3	Ceramica Satinata / Satin Ceramic

Vaso in ceramica lucida o satinata, sospeso con scarico a parete, completo di sedile avvolgente FLAT con sistema di sganciamento rapido, realizzato in resina termoindurente con chiusura rallentata "soft-close".

High gloss or satin suspended ceramic water closet with wall drain, complete with seat and cover FLAT made of thermosetting resin, quick release system and soft closing hinges.

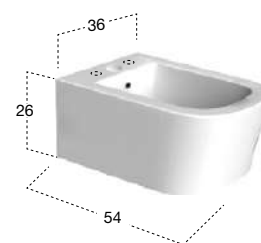

H	P	L	art.	
26	54	36	KOMODO2	Ceramica Lucida / High gloss Ceramic
26	54	36	KOMODO4	Ceramica Satinata / Satin Ceramic

Bidet monoforo in ceramica lucida o satinata, sospeso con scarico a parete.

High gloss or satin suspended ceramic bidet with wall drainage and single tap hole.

KOMODO





ONDA design Nevio Tellatin

Una linea che rompe gli equilibri lasciando immutata la sensazione di armonia, un segno che esprime eleganza senza perdere la funzionalità dell'insieme, un tratto deciso e dinamico che si sviluppa con continuità e si integra perfettamente, sovrapponendosi, all'essenzialità di una geometria pura. Organicità ed essenzialità convivono in un elemento tecnico che diventa espressivo. Onda è la placca di comando in acciaio inox per cassetta wc nella quale si esprime tutta la pulizia formale di antoniolupi, l'attenzione ai dettagli, la qualità dei materiali e delle superfici riservata anche agli accessori. Un disegno semplice ma allo stesso tempo innovativo, un equilibrio proporzionale perfetto che trasmette immediatamente la funzione per la quale è stata pensata senza per questo ridurla a mero elemento tecnico. Un gesto semplice, un tasto unico basculante che assicura una piacevolezza tattile che diventa ergonomia e facilità d'uso. Onda è disponibile nella finitura lucida o satinata.

A harmonious item, a sign that expresses elegance without losing its function, a decisive and dynamic trait that develops continuously and seamlessly integrating perfectly within the space, overlapping essence of pure geometry. Organic and simplicity coexist in a technical element which becomes meaningful. Onda is a flush plate in stainless steel for water cisterns which expresses the formal clean lines of antoniolupi, attention to detail, the quality of materials, also reserved for accessories.

A simple design but at the same time innovative, a perfect proportional balance that immediately transmits the function for which it was conceived without reducing it to a mere technical element. A simple gesture, a single button that provides a pleasing touch that becomes ergonomic and easy to use. Onda is available in polished or in a satin finish.



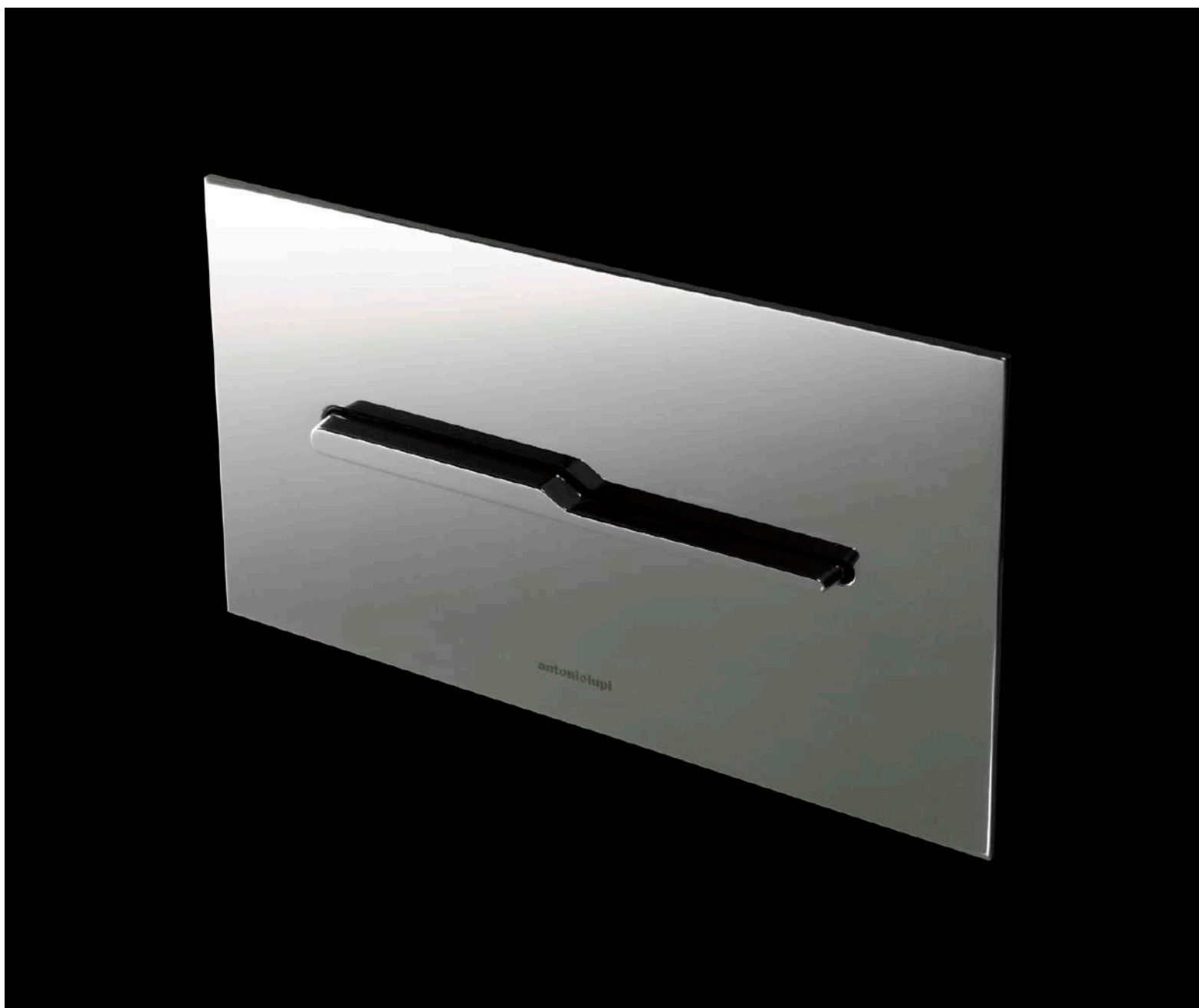

H	L	art.
15,5	27	ONDA

Placca di comando per cassetta wc a tasto unico basculante per il risciacquo a due quantità in acciaio inox AISI 304 satinato o lucido, completa di kit adattatore di montaggio.

Mechanical dual flush plate for toilet cisterns in satin or polished stainless steel AISI 304 complete with installation adapter kit.

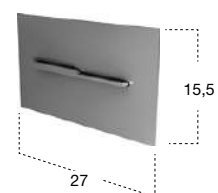

TENSO design GI-RA

Modello e design registrato, brevetto depositato
Registered model and design, patent pending

Un nuovo concetto di idroscopino in acciaio inox, con la sicurezza della doppia chiusura: ruotando la placchetta di 90°, contemporaneamente si apre l'acqua e la finestra che lo nasconde con il suo flessibile... basta ruotare la testina per dare il via al getto.

Una volta ruotata di nuovo la testina e riposto velocemente l'idroscopino nel suo alloggiamento, ruotando la placchetta, chiudiamo insieme, con un unico gesto, acqua e finestra.

A new concept of hydrobrush in satin stainless steel with double locking security: by rotating the plate 90°, water and the window that contains it with a flexible hose will open simultaneously... simply rotate the head for water flow.

Once rotated the head again and stowed quickly away, rotate the plate and close with one single step, water and window.



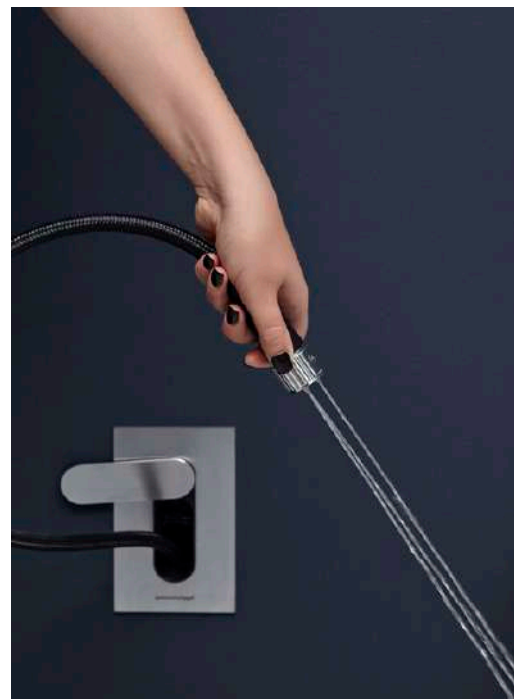
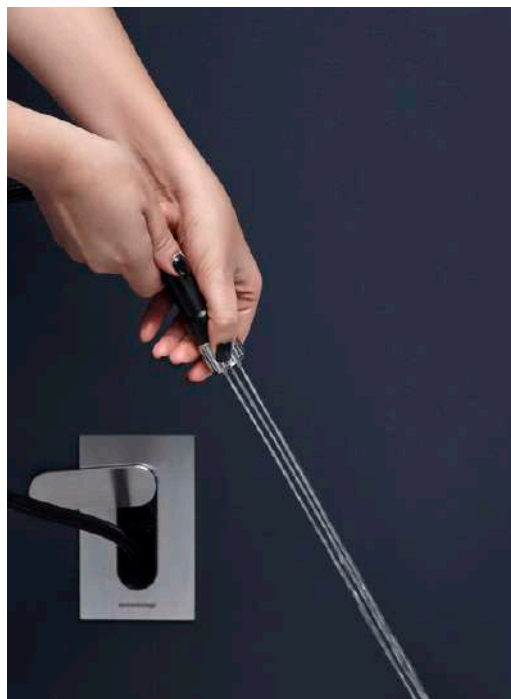

H	P	L	art.
50	8	34	TENSO

Idroscopino da incasso in acciaio inox satinato o lucido con doppio sistema di apertura e chiusura acqua e flessibile 85 cm ad alta pressione.

Encased hydrobrush cleaner in satin or polished stainless steel with double opening and closing water system and high pressure flexible hose 85 cm.

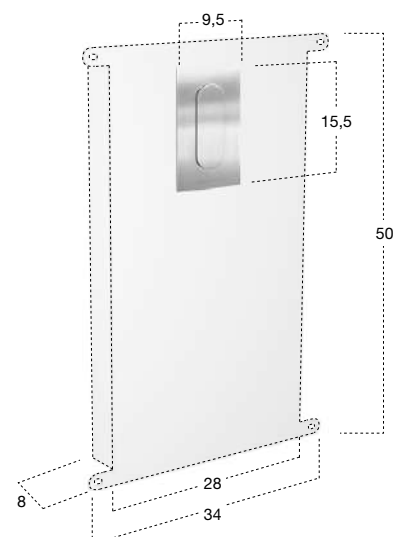

CARTATENSO design GI-RA

Modello e design registrato, brevetto depositato
Registered model and design, patent pending





H	P	L	art.
50	8	34	CARTATENSO

Porta carta e idroscopino da incasso in acciaio inox satinato o lucido con doppio sistema di apertura e chiusura acqua e flessibile di 85 cm ad alta pressione.

Encased hydrobrush cleaner and paper roll holder in satin or polished stainless steel with double opening and closing water system and high pressure flexible hose 85 cm.

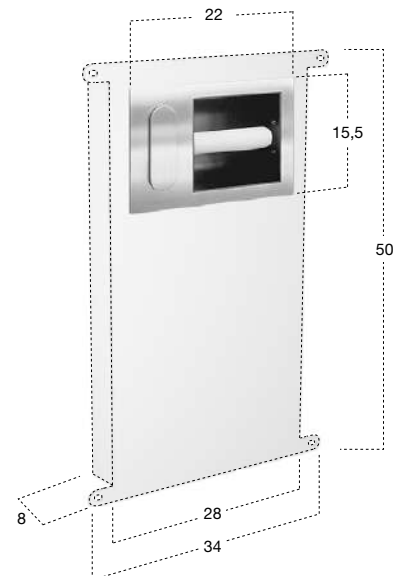



GIRO_SCHIZZO design GI-RA

Un elemento tecnico che assume una valenza estetica nella definizione dell'immagine complessiva dello spazio, un complemento che propone una forma compatta e rigorosa nella quale le geometrie degli elementi che lo compongono, si integrano con equilibrio ed eleganza discreta. GIRO_SCHIZZO è l'idroscopino da esterno in acciaio satinato AISI 316/L, completo di supporto e presa d'acqua a parete, con flessibile 100 cm ad alta pressione.

GIRO_SCHIZZO non si nasconde nella parete, ma rivela sin da subito la propria presenza, perché anche gli elementi funzionali possano assumere una connotazione formale. La funzionalità rimane però l'obiettivo primario. Grazie a un getto potente e concentrato, permette di assolvere alle funzioni di pulizia in modo ottimale.

A technical element that assumes value in the overall aesthetics when defining space, a complement which proposes a compact and rigorous form in which the geometries of the elements that compose it are integrated with balance and discreet elegance. GIRO_SCHIZZO is a wall mounted hydrobrush in brushed steel AISI 316/L, complete with support and high pressure flexible hose 100 cm. GIRO_SCHIZZO is not hidden in the wall but reveals its presence because even functional elements may take on a formal connotation. The functionality, however, remains the primary objective. With a powerful and concentrated jet optimal cleaning results are obtained.



GIRO_SCHIZZO

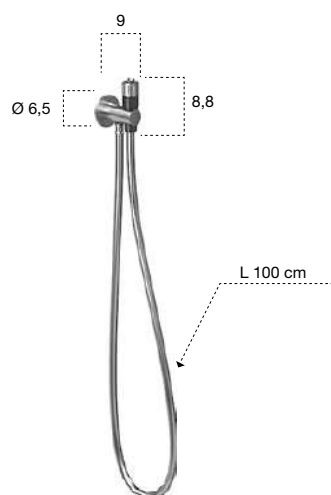
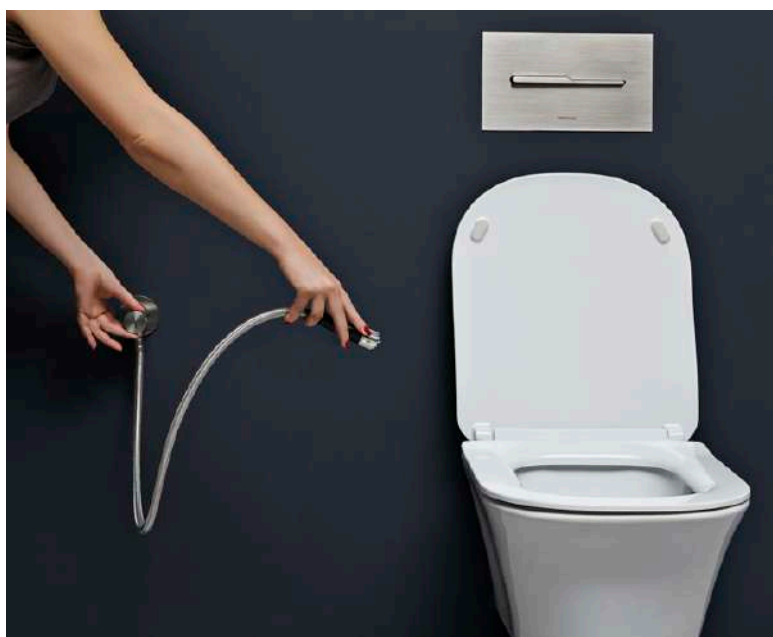

H	P	L	art.
8,8	9	6,5	GIRO_SCHIZZO

Idroscopino in acciaio inox satinato AISI 316/L con presa d'acqua e chiusura integrata al supporto a parete, completo di flessibile 100 cm ad alta pressione.

Wall mounted hydrobrush in satin stainless steel AISI 316/L complete with support and water outlet, high pressure flexible hose 100 cm.



FLUMOOD

Corian nel 2001, il Cristalplant nel 2004 e poi ancora il Ceramilux...ora il Flumood, un materiale di nuova generazione brevetto e proprietà di antoniolupi. L'ultimo...per ora...

Dalla ricerca dell'azienda è nato Flumood, un nuovo materiale brevettato e di proprietà, ecologico, compatto, non poroso e atossico, con una superficie facilmente pulibile con i comuni detergenti per la pulizia domestica e ripristinabile in caso di graffi o segni derivanti dall'uso quotidiano.

Perfetto per l'ambiente bagno Flumood è in grado di associare alla notevole resistenza una presenza estetica di notevole impatto ma anche un'estrema piacevolezza al tatto, che lo fanno preferire sia per la realizzazione di lavabi ma anche per piani d'appoggio di qualsiasi dimensione e forma. Proprio l'aspetto materico è una delle sue caratteristiche vincenti. Può essere infatti proposto sia nella finitura Satin che in quella Texture, caratterizzata da un effetto "raw" simile a quello di una pietra a spacco. Senza dimenticare il colore, anch'esso tema portante della ricerca dell'azienda. Flumood viene proposto, oltre al bianco, anche in versione colorata grazie alla goffratura esterna dei prodotti come da cartella colori antoniolupi.

Oggi il nuovo materiale viene proposto su alcune nuove collezioni ma la sua diffusione nell'ambito della gamma di proposte è rapida e concreta. A partire da Simplo disegnato da Mario Ferrarini, sia nella versione freestanding che da appoggio, per proseguire con Fusto di Nevio Tellatin ma anche con le proposte, sempre dedicate al mondo del lavabo, Calco e Senso. La versatilità del Flumood permette di realizzare qualsiasi forma, di esplorare nuovi territori, di interpretare esigenze diverse.

FLUMOOD

Corian in 2001, Cristalplant in 2004 and then Ceramilux ... now Flumood, a next-generation material and patent owned by antoniolupi. The last ... for now ...

From company research Flumood was born, a new patented and owned material, eco-friendly, compact, non-porous and non-toxic, with an easily cleanable surface and recoverable in case of scratches or marks derived from daily use.

Flumood is perfect for the bathroom environment with a considerable resistance and strong aesthetic impact, extremely pleasant to the touch referred for the construction of basins but also for tops of any size and shape. Just the material aspect is one of its winning features. It can be in fact proposed in both the Satin or Texture finish, characterized by a "raw" effect similar to that of a split stone. Not to mention the color, which is also the main theme of the research company. Flumood is available in white as well as other colors proposed by the company.

Today, this new material is offered on new collections but diffused within the proposed range. From Simplo designed by Mario Ferrarini, both the freestanding version and the top mounted sink, followed by Fusto, Nevio Tellatin and sinks, Calco and Senso. The versatility of Flumood allows to create any form, to break new ground, to interpret different needs.

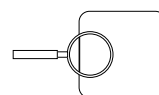

ANTIBATTERICO
ATOSSICO
ANTIBACTERIAL
NON TOXIC

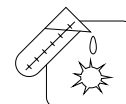

RESISTENTE ALLE
SOSTANZE CHIMICHE
RESISTANT TO
CHEMICALS



IGNIFUGO
FIREPROOF



VERNICIABILE
PAINTABLE

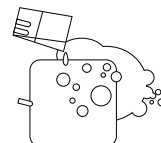

IDROREPELLENTE
WATER REPELLENT

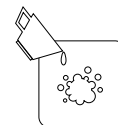

ANTIMACCHIA
STAIN RESISTANT

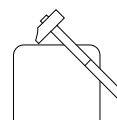

SOLIDO
SOLID



ECOLOGICO
ECOLOGICAL

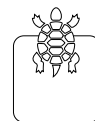

LUNGA DURATA
LONG LIFE

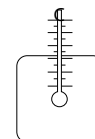

RESISTENTE ALLE
VARIAZIONI DI TEMPERATURA
RESISTANT TO VARIATIONS
IN TEMPERATURE

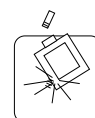

OTTIMA RESISTENZA AI GRAFFI
E ALLE ABRASIONI
EXCELLENT RESISTANCE TO
SCRATCHES AND ABRASIONS



CARTEGGIABILE
COME IL LEGNO
SAND LIKE WOOD

TOP / TOPS

top / tops





LAVABI INTEGRATI IN FLUMOOD (BASICO, NIDO, NUVOLA, PODIO) design Nevio Tellatin

Integrazione perfetta, assoluta continuità materica, linee pulite ed essenziali: i lavabi integrati nel piano realizzati in Flumood, il nuovo materiale brevettato da antoniolupi, assicurano estetica coordinata e pulizia delle linee, coordinandosi al meglio con diverse tipologie di contenitori e collezioni di mobili. Basico, dalla forma rettangolare, è il lavabo integrato caratterizzato da una geometria perfetta e da un bordo posteriore ribassato che può alloggiare il rubinetto e/o servire come mensola d'appoggio per sapone, dispenser o altri accessori. Disponibile solo nella versione Satin (liscia) propone un bacino con profondità variabile, 47 o 54 cm. Nido e Nuvola sono due lavabi integrati di dimensione standard, entrambi con profondità di 54 cm. Nido ha una forma rettangolare ed è disponibile sia nella versione Satin che in finitura Texture (effetto pietra), a definire un piacevole contrasto e una sensazione tattile inedita tra top e interno del volume. Nuvola invece, ha un bacino dalla forma ovale che morbidamente definisce una depressione rispetto al livello del top ed è disponibile solamente nella finitura Satin. Maxi capacità invece per Podio che presenta un bacino molto grande, dalla larghezza pressoché raddoppiata rispetto a un lavabo tradizionale. Viene proposto nelle finiture Satin e Texture e può essere caratterizzato da un pianetto copri piletta, sempre realizzato in Flumood, che divide di fatto il bacino in permettendo di passare facilmente da un lavabo singolo a uno doppio. Rimosso dal volume e posizionato sopra il top questo pratico ed elegante "rialzo" diventa una piccola mensola su cui posizionare accessori e strumenti per l'igiene personale. Un dettaglio sofisticato, un elemento funzionale che permette di accrescere la versatilità del lavabo.

INTEGRATED SINKS IN FLUMOOD (BASICO, NIDO, NUVOLA, PODIO) design Nevio Tellatin

Perfect integration, absolute continuity of material, clean and essential lines: the built-in washbasins made in Flumood, the new patented antoniolupi material, ensure coordinated aesthetics and clean lines, coordinating best with different types of containers and furniture collections. Basico, rectangular in shape, is the built-in washbasin with a perfect geometry and a low back edge that can accommodate a tap and / or serve as a support stand for soap dispensers or other accessories. Only available in the Satin version (smooth) offers a basin with varying depths, 47 or 54 cm. Nido and Nuvola are two integrated standard washbasins, both with a depth of 54 cm. The Nido basin has a rectangular shape and is available in both Satin and Texture finishes (stone effect), to define a pleasant contrast and a tactile feel between the top and inside of the bowl. Nuvola, on the other hand, has an oval shaped basin and is only available in the Satin finish. Maxi capacity for Podio, which has a very large basin, with a width almost doubled compared to a traditional washbasin. It is proposed in the Texture and Satin finish and can be characterized by a drain cover, all in Flumood, which divides the basin transforming easily from a single to a double sink. Removable from the bowl and placed on the top becomes a small shelf on which to place accessories and personal items. A sophisticated detail, a functional element that enhances the versatility of the washbasin.



top / tops

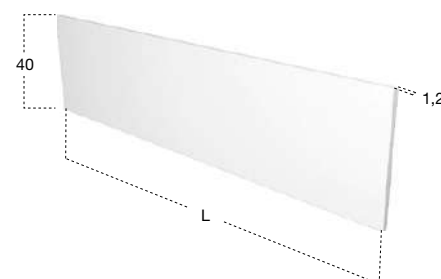

H	P	L	art.	
40	1,2	da / from 54	a / to 272,4	BC140

Alzatina in Flumood in finitura Satin o Texture.

Flumood backsplash in Satin or Texture finish.





top / tops



Per collezione / For collection

BESPOKE - PIANA - LUNARIA - TEMPRA

H	P	L	art.
1,2	40	da / from 54 a / to 272,4	BC140
	47		BC147
	54		BC154

Per collezione / For collection

PANTA REI

H	P	L	art.
1,2	40	da / from 54 a / to 216	BC240
	47		BC247
	54		BC254

Per collezione / For collection

PLANETA

H	P	L	art.
1,2	40	da / from 54 a / to 216	BC340
	47		BC347
	54		BC354

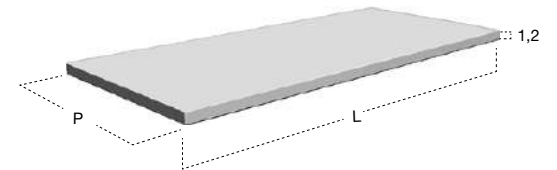

Top in Flumood finitura Satin o Texture, spessore 12 mm.

Top in Flumood Satin or Texture finish, 12 mm thick.

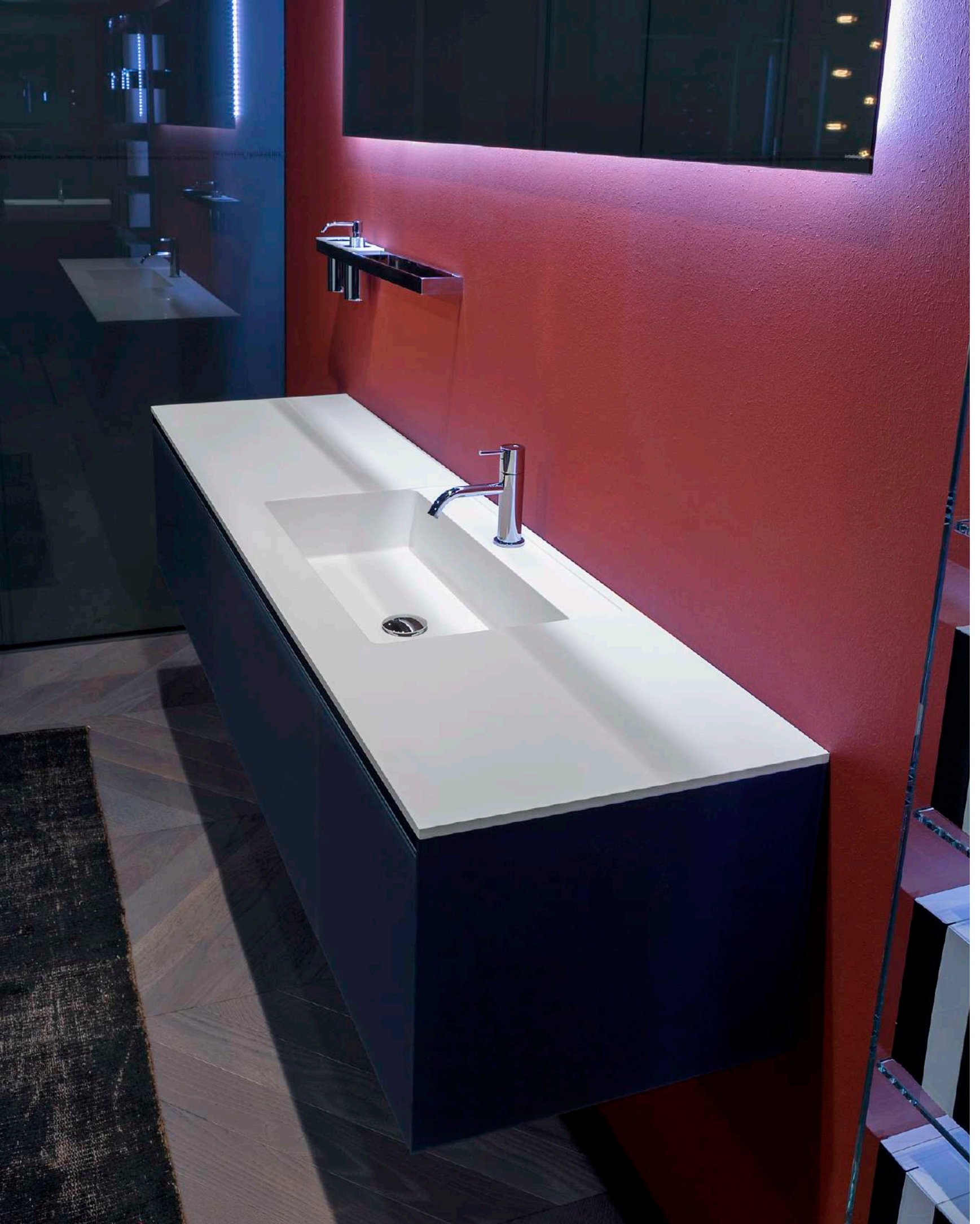



top / tops



Per collezione / For collection				
BESPOKE - PIANA - LUNARIA - TEMPRA				
H	P	L	art.	
1,2	47	da / from 72	a / to 272,4	BC147 + BASIC047
	54			BC154 + BASIC054

Per collezione / For collection				
PANTA REI				
H	P	L	art.	
1,2	47	da / from 72	a / to 216	BC247 + BASIC047
	54			BC254 + BASIC054

Per collezione / For collection				
PLANETA				
H	P	L	art.	
1,2	47	da / from 72	a / to 216	BC347 + BASIC047
	54			BC354 + BASIC054

Top con lavabo integrato sopraiano in Flumood in finitura Satin, spessore 12 mm completo di piletta con scarico libero e raccordo per sifone.

N.B. solo per porta lavabi H 37,5 e H 50 cm. Nei porta lavabi H 37,5 è possibile inserire solo sifone art. MICRO.

Top with integrated sink in Flumood Satin finish, 12 mm thick, complete with drain pipe fitting and open plug.

P.S. only for sink units cm 37,5 and 50 H. In sink units cm 37,5 H it is only possible to use siphon art. MICRO.

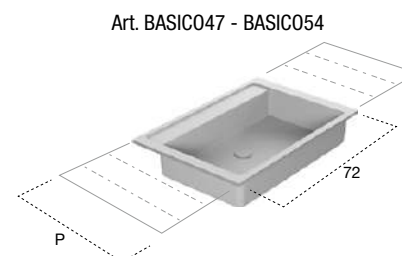

Art. BASIC047 - BASIC054

+

Art. BC147 - BC247 - BC347
Art. BC154 - BC254 - BC354

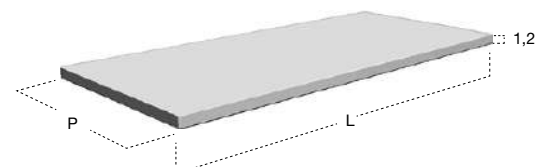





top / tops



Per collezione / For collection				
BESPOKE - PIANA - LUNARIA - TEMPRA				
H	P	L	art.	
1,2	47	da / from 144	a / to 272,4	BC147 + n° 2 BASIC047
	54			BC154 + n° 2 BASIC054

Per collezione / For collection				
PANTA REI				
H	P	L	art.	
1,2	47	da / from 144	a / to 216	BC247 + n° 2 BASIC047
	54			BC254 + n° 2 BASIC054

Per collezione / For collection				
PLANETA				
H	P	L	art.	
1,2	47	da / from 144	a / to 216	BC347 + n° 2 BASIC047
	54			BC354 + n° 2 BASIC054

Top con doppio lavabo integrato sopra piano in Flumood finitura Satin, spessore 12 mm, completo di piletta con scarico libero e raccordo per sifone.

N.B. solo per porta lavabi H 37,5 e H 50 cm. Nei porta lavabi H 37,5 è possibile inserire solo sifone art. MICRO.

Top with double integrated sink in Flumood Satin finish, 12 mm thick, with drain pipe fitting and open plug.

P.S. only for sink units cm 37,5 and 50 H. In sink units cm 37,5 H it is only possible to use siphon art. MICRO.

Art. BASIC047 - BASIC054

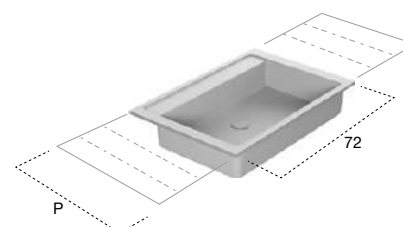

+

Art. BC147 - BC247 - BC347
Art. BC154 - BC254 - BC354

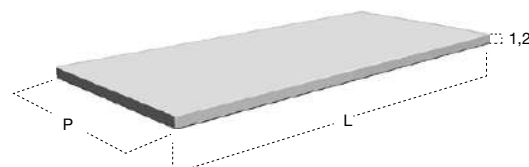





top / tops



Per collezione / For collection				
BESPOKE - PIANA - LUNARIA - TEMPRA				
H	P	L	art.	
1,2	54	da / from 54	a / to 272,4	BC154 + NID054
	54	da / from 108	a / to 272,4	BC154 + n° 2 NID054

Per collezione / For collection				
PANTA REI				
H	P	L	art.	
1,2	54	da / from 54	a / to 216	BC254 + NID054
	54	da / from 108	a / to 216	BC254 + n° 2 NID054

Per collezione / For collection				
PLANETA				
H	P	L	art.	
1,2	54	da / from 54	a / to 216	BC354 + NID054
	54	da / from 108	a / to 216	BC354 + n° 2 NID054

Top con singolo o doppio lavabo integrato in Flumood spessore 12 mm finitura Satin o Texture, completo di piletta con scarico libero e raccordo per sifone.

N.B. solo per porta lavabi H 37,5 e H 50 cm. Nei porta lavabi H 37,5 è possibile inserire solo sifone art. MICRO.

Top with single or double integrated sink in Flumood Satin or Texture finish 12 mm thick, with drain pipe fitting and open plug.

P.S. only for sink units cm 37,5 and 50 H. In sink units cm 37,5 H it is only possible to use siphon art. MICRO.

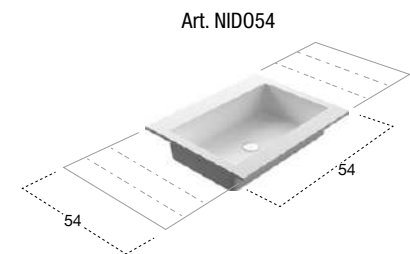

+

Art. BC154 - BC254 - BC354

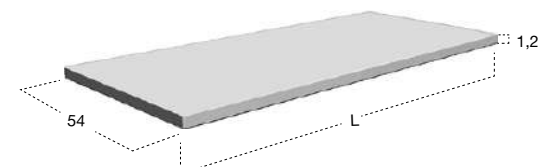

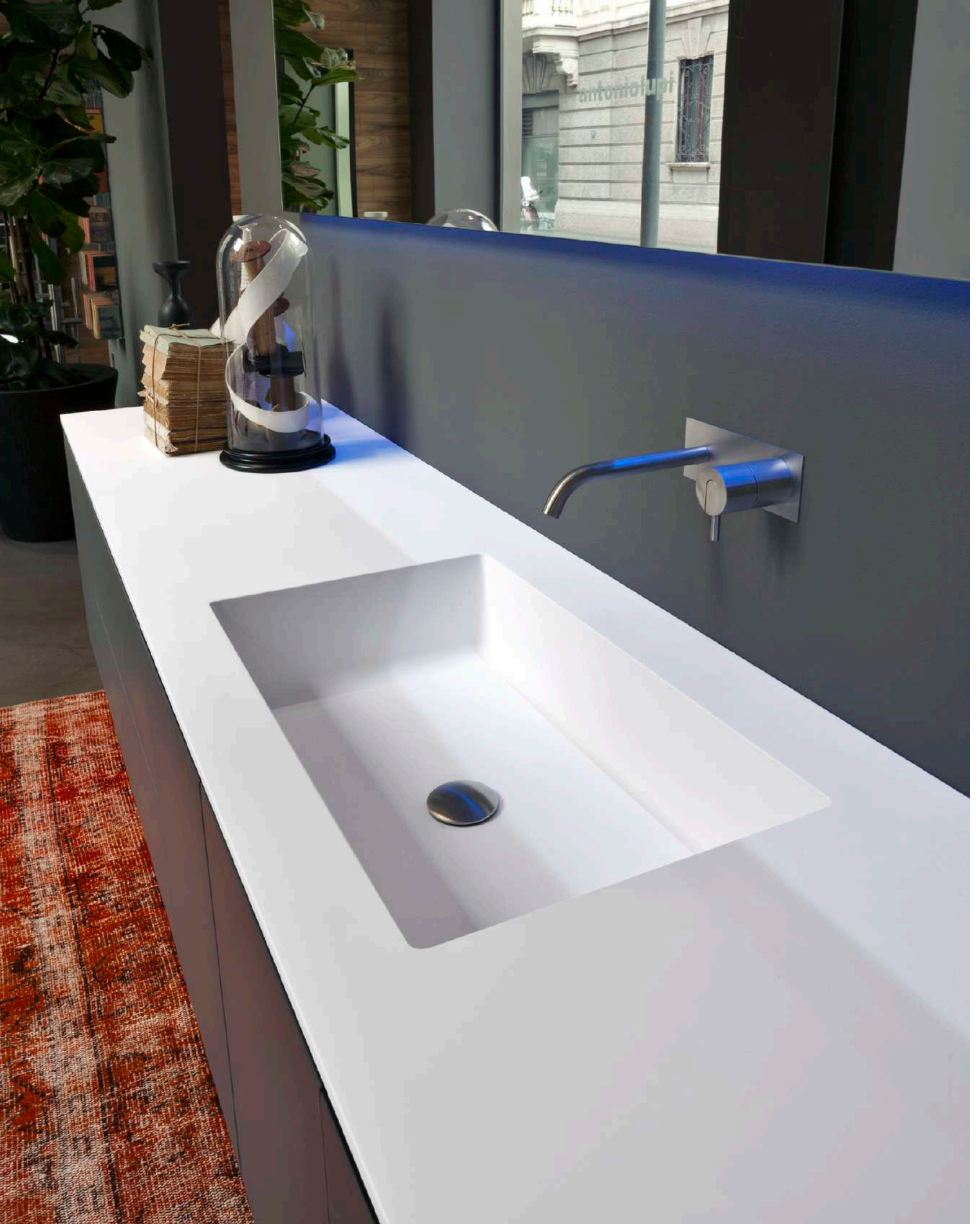



top / tops



Per collezione / For collection				
BESPOKE - PIANA - LUNARIA - TEMPRA				
H	P	L	art.	
1,2	54	da / from 72	a / to 272,4	BC154 + NIDO
	54	da / from 144	a / to 272,4	BC154 + n° 2 NIDO
Per collezione / For collection				
PANTA REI				
H	P	L	art.	
1,2	54	da / from 72	a / to 216	BC254 + NIDO
	54	da / from 144	a / to 216	BC254 + n° 2 NIDO
Per collezione / For collection				
PLANETA				
H	P	L	art.	
1,2	54	da / from 72	a / to 216	BC354 + NIDO
	54	da / from 144	a / to 216	BC354 + n° 2 NIDO

Top con singolo o doppio lavabo integrato in Flumood spessore 12 mm finitura Satin o Texture, completo di piletta con scarico libero e raccordo per sifone.

N.B. solo per porta lavabi H 37,5 e H 50 cm. Nei porta lavabi H 37,5 è possibile inserire solo sifone art. MICRO.

Top with single or double integrated sink in Flumood Satin or Texture finish 12 mm thick, with drain pipe fitting and open plug.

P.S. only for sink units cm 37,5 and 50 H. In sink units cm 37,5 H it is only possible to use siphon art. MICRO.

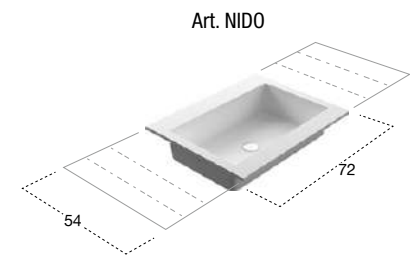

Art. NIDO

+

Art. BC154 - BC254 - BC354

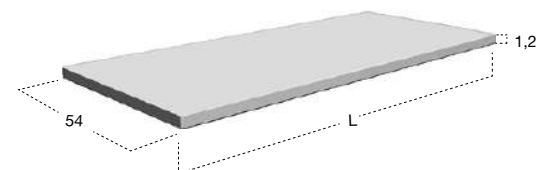





top / tops



Per collezione / For collection

BESPOKE - PIANA - LUNARIA - TEMPRA

art.

H	P	L			art.
1,2	54	da / from 72	a / to 272,4		BC154 + NUVOLA
	54	da / from 144	a / to 272,4		BC154 + n° 2 NUVOLA

Per collezione / For collection

PANTA REI

art.

H	P	L			art.
1,2	54	da / from 72	a / to 216		BC254 + NUVOLA
	54	da / from 144	a / to 216		BC254 + n° 2 NUVOLA

Per collezione / For collection

PLANETA

art.

H	P	L			art.
1,2	54	da / from 72	a / to 216		BC354 + NUVOLA
	54	da / from 144	a / to 216		BC354 + n° 2 NUVOLA

Top con singolo o doppio lavabo integrato in Flumood spessore 12 mm finitura Satin, completo di piletta con scarico libero e raccordo per sifone.

N.B. solo per porta lavabi H 37,5 e H 50 cm. Nei porta lavabi H 37,5 è possibile inserire solo sifone art. MICRO.

Top with single or double integrated sink in Flumood Satin finish 12 mm thick, with drain pipe fitting and open plug.

P.S. only for sink units cm 37,5 and 50 H. In sink units cm 37,5 H it is only possible to use siphon art. MICRO.

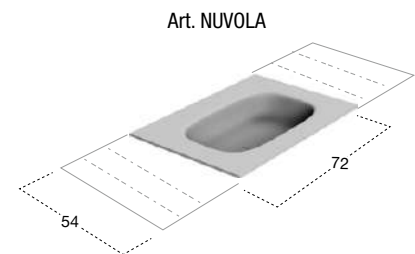

+

Art. BC154 - BC254 - BC354

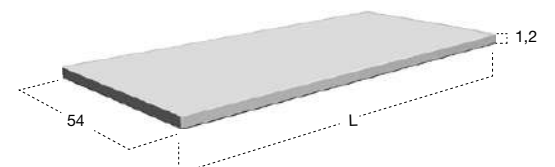

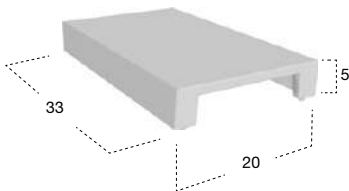

H	P	L	art.
5	33	20	PIANETTO

Pianetto optional copripiletta in Flumood finitura Satin.

Optional Flumood drain cover in satin finish.



top / tops



Per collezione / For collection					
BESPOKE - PIANA - LUNARIA					
H	P	L	art.		
1,2	54	da / from 108	a / to 272,4	BC154 + PODIO	

Per collezione / For collection					
PANTA REI					
H	P	L	art.		
1,2	54	da / from 108	a / to 216	BC254 + PODIO	

Per collezione / For collection					
PLANETA					
H	P	L	art.		
1,2	54	da / from 108	a / to 216	BC354 + PODIO	

Top con lavabo integrato in Flumood finitura Satin o Texture, spessore 12 mm completo di piletta con scarico libero e raccordo per sifone.

N.B. solo per porta lavabi H 37,5 e H 50 cm. Nei porta lavabi H 37,5 è possibile inserire solo sifone art. MICRO.

Top with integrated sink in Flumood Satin or Texture finish, 12 mm thick, complete with drain pipe fitting and open plug.

P.S. only for sink units cm 37,5 and 50 H. In sink units cm 37,5 H it is only possible to use siphon art. MICRO.

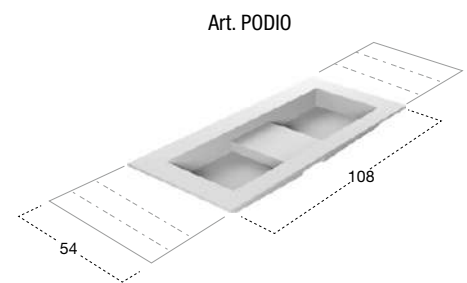

+

Art. BC154 - BC254 - BC354

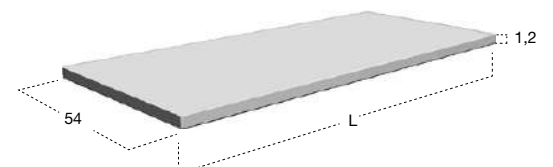

PODIO





top / tops





top / tops

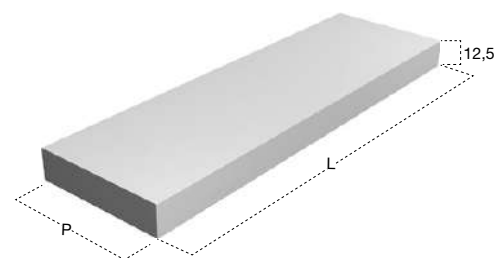

H	P	L	art.	
12,5	40	da / from 72	a / to 272,4	BCS40
	47			BCS47
	54			BCS54

Top scatolare in Flumood in finitura Satin o Texture, spessore 125 mm.

Suspended Flumood top in Satin or Texture finish, 125 mm thick.



Art. BASIC047 - BASIC054

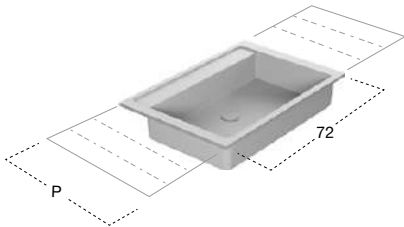

+

Art. BCS47 - BCS54

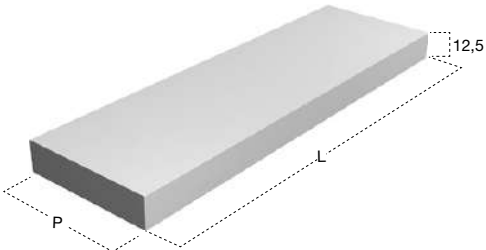

H	P	L	art.
12,5	47	da / from 72 a / to 272,4	BCS47 + BASIC047
	54		BCS54 + BASIC054

Top con lavabo integrato in Flumood finitura Satin, spessore 125 mm, completo di piletta con scarico libero e raccordo per sifone.

Top with integrated sink in Flumood Satin finish 125 mm thick, complete with drain pipe fitting and open plug.

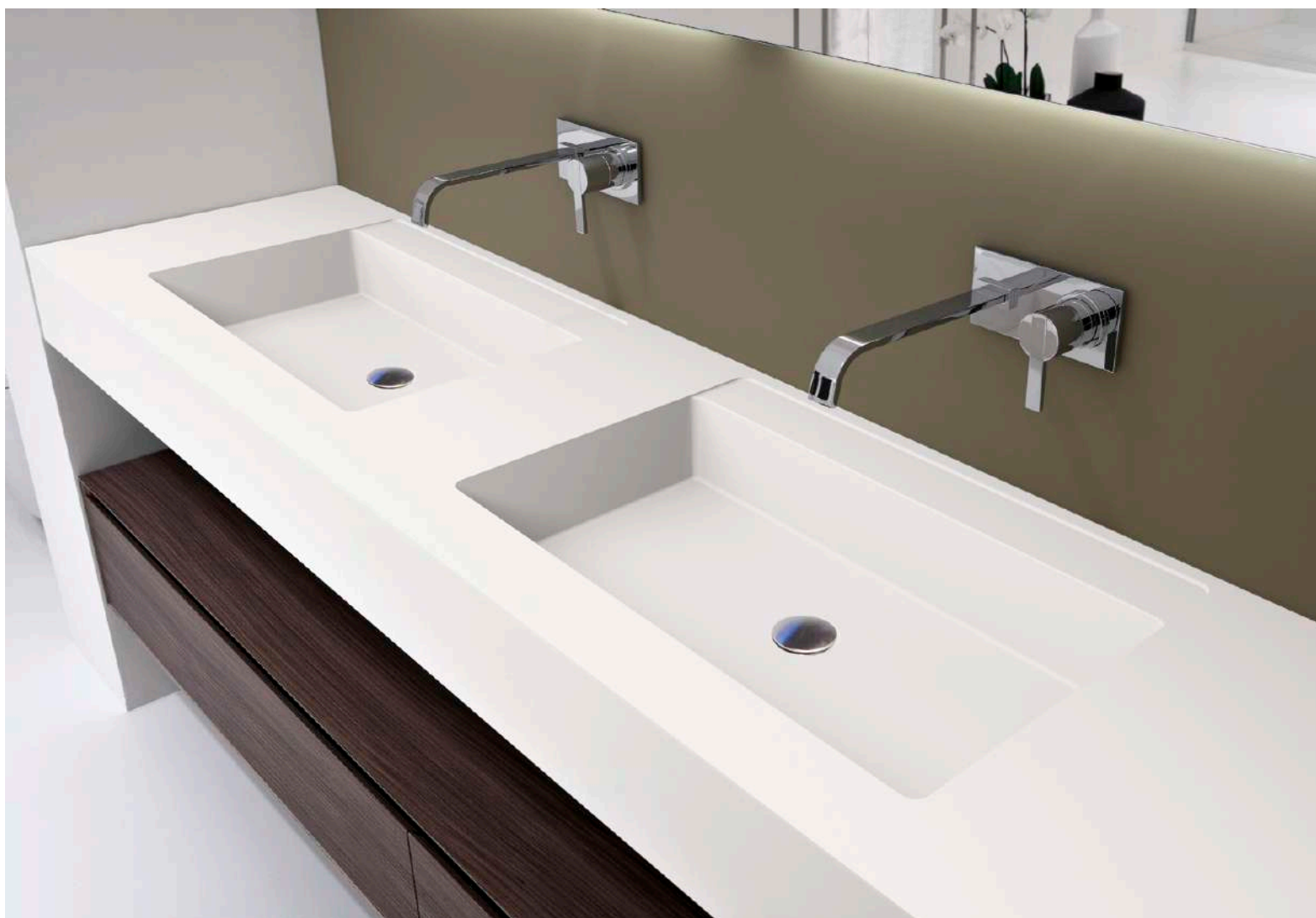

top / tops



Art. BASIC047 - BASIC054

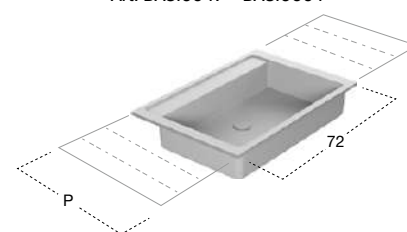

+

Art. BCS47 - BCS54

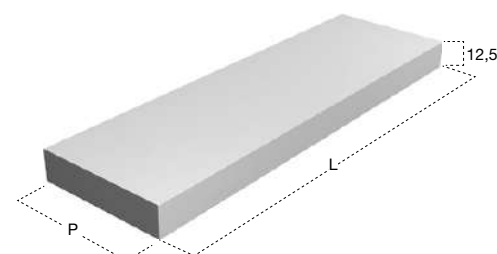

H	P	L	art.	
12,5	47	da / from 144	a / to 272,4	BCS47 + n° 2 BASIC047
	54			BCS54 + n° 2 BASIC054

Top con doppio lavabo integrato in Flumood finitura Satin spessore 125 mm, completo di piletta con scarico libero e raccordo per sifone.

Top with double integrated sink in Flumood Satin finish 125 mm thick, complete with drain pipe fitting and open plug.



Art. NID054

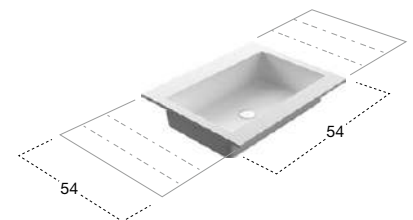

+

Art. BCS54

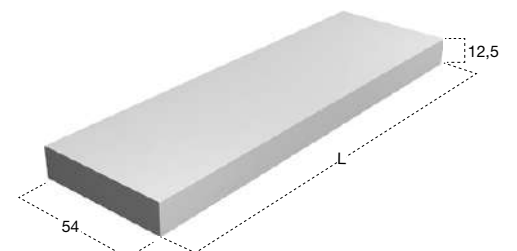

H	P	L	art.		
12,5	54	da / from 54	a / to 272,4	BCS54 + NID054	
		54	da / from 108	a / to 272,4	BCS54 + n° 2 NID054

Top con singolo o doppio lavabo integrato in Flumood finitura Satin o Texture spessore 125 mm, completo di piletta con scarico libero e raccordo per sifone.

Top with single or double integrated sink in Flumood Satin or Texture finish 125 mm thick, complete with drain pipe fitting and open plug.



top / tops

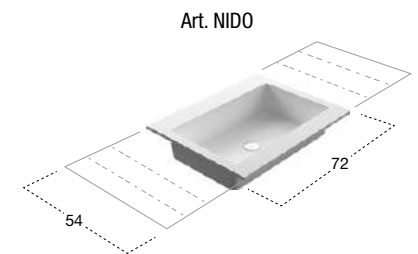

Art. NIDO

+

Art. BCS54

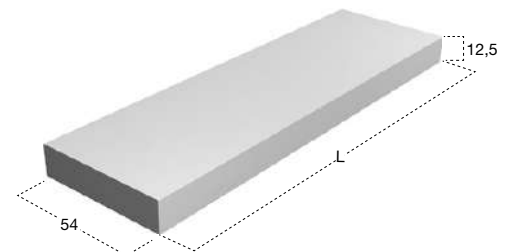

H	P	L	art.	
12,5	54	da / from 72	a / to 272,4	BCS54 + NIDO
	54	da / from 144	a / to 272,4	BCS54 + n° 2 NIDO

Top con singolo o doppio lavabo integrato in Flumood finitura Satin o Texture spessore 125 mm, completo di piletta con scarico libero e raccordo per sifone.

Top with single or double integrated sink in Flumood Satin or Texture finish 125 mm thick, complete with drain pipe fitting and open plug.

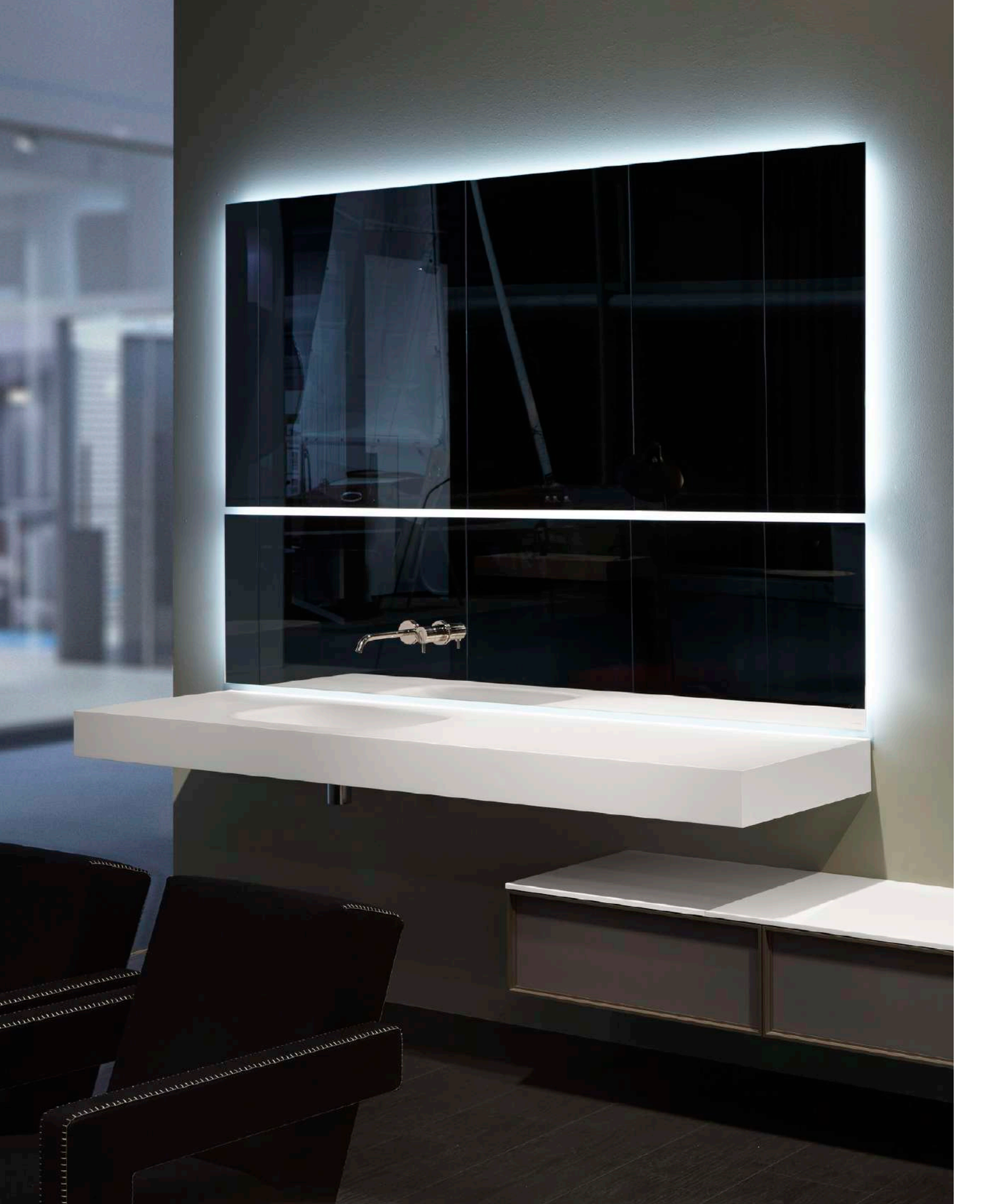



top / tops



H	P	L	art.	
12,5	54	da / from 72	a / to 272,4	BCS54 + NUVOLA
	54	da / from 144	a / to 272,4	BCS54 + n° 2 NUVOLA

Top con singolo o doppio lavabo integrato in Flumood finitura Satin spessore 125 mm, completo di piletta con scarico libero e raccordo per sifone.

Top with single or double integrated sink in Flumood Satin finish 125 mm thick, complete with drain pipe fitting and open plug.

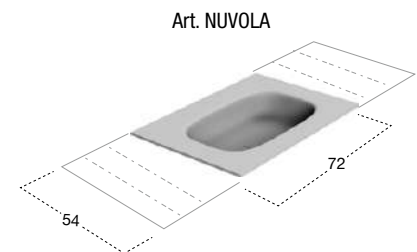

+

Art. BCS54

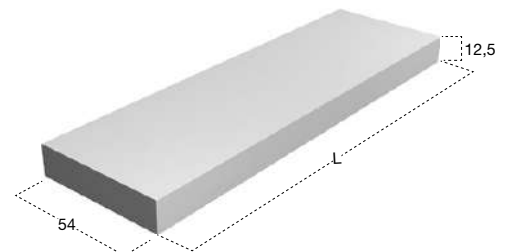





top / tops

H	P	L	art.
5	33	20	PIANETTO

Pianetto optional copripiletta in Flumood finitura Satin.

Optional Flumood drain cover in satin finish.

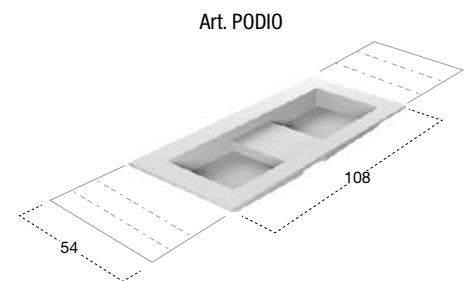
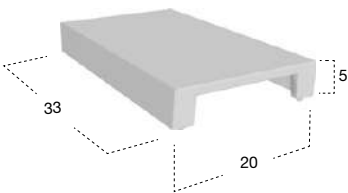

Art. PODIO

+

Art. BCS54

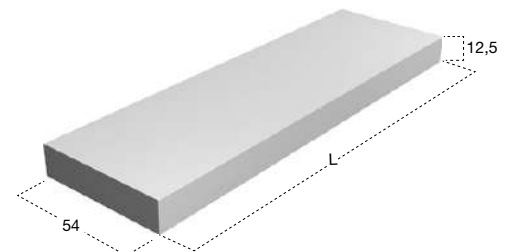

H	P	L	art.
12,5	54	da / from 108 a / to 272,4	BCS54 + PODIO

Top con lavabo integrato in Flumood finitura Satin o Texture, spessore 125 mm, completo di piletta con scarico libero e raccordo per sifone.

Top with integrated sink in Flumood Satin or Texture finish, 125 mm thick complete with drain pipe fitting and open plug which may be wall mounted or used on furniture.



Per collezione / For collection

BESPOKE - PIANA - LUNARIA - TEMPRA

H	P	L	art.
1,2	40	da / from 27 a / to 299,4	CR140
	54		CR154

Per collezione / For collection

PANTA REI

H	P	L	art.
1,2	40	da / from 36 a / to 216	CR240
	54		CR254

Per collezione / For collection

PLANETA

H	P	L	art.
1,2	40	da / from 27 a / to 216	CR340
	54		CR354

Top o alzatina in Corian spessore 12 mm.

Top or backsplash in Corian 12 mm thick.

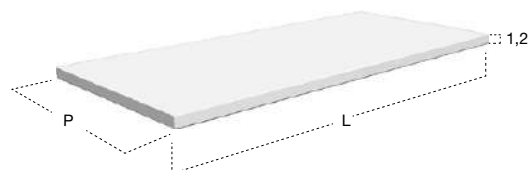



top / tops

Per collezione / For collection

BESPOKE - PIANA - LUNARIA - TEMPRA

art.

H	P	L			
1,2	40	da / from 72	a / to 299,4	CR140 + MYSLOT472	
	40	da / from 90	a / to 299,4	CR140 + MYSLOT490	

Per collezione / For collection

PANTA REI

art.

H	P	L			
1,2	40	da / from 72	a / to 216	CR240 + MYSLOT472	
	40	da / from 90	a / to 216	CR240 + MYSLOT490	

Per collezione / For collection

PLANETA

art.

H	P	L			
1,2	40	da / from 72	a / to 216	CR340 + MYSLOT472	
	40	da / from 90	a / to 216	CR340 + MYSLOT490	

Top con lavabo integrato in Corian spessore 12 mm, con sistema di scarico predisposto per sifone.
 N.B. solo per porta lavabi H 37,5 e H 50 cm. Nei porta lavabi H 37,5 è possibile inserire solo sifone art. MICRO. Solo per rubinetteria a parete.

Top with integrated sink completely in Corian 12 mm thick, with drain prepared for siphon.
 P.S. only for sink units cm 37,5 and 50 H. In sink units cm 37,5 H it is only possible to use siphon art. MICRO. Only for wall mount tap.

Art. MYSLOT472 - MYSLOT490

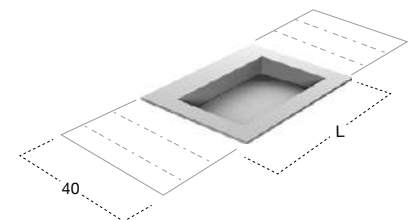

+

Art. CR140 - CR240 - CR340

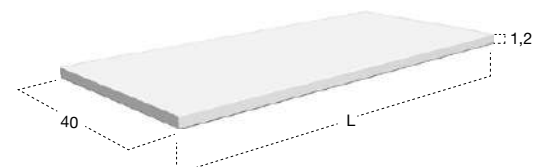

MYSLOT



Art. MYSLOT72 - MYSLOT90

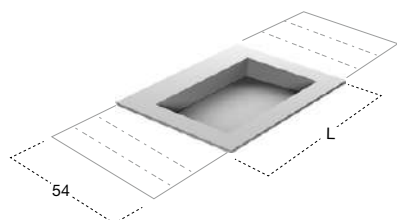

+

Art. CR154 - CR254 - CR354

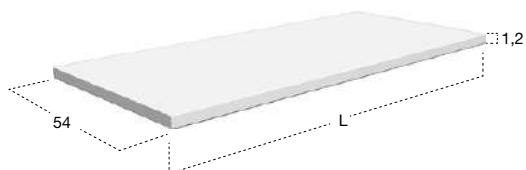

Per collezione / For collection

BESPOKE - PIANA - LUNARIA - TEMPRA

art.

H	P	L		
1,2	54	da / from 72	a / to 299,4	CR154 + MYSLOT72
	54	da / from 90	a / to 299,4	CR154 + MYSLOT90

Per collezione / For collection

PANTA REI

art.

H	P	L		
1,2	54	da / from 72	a / to 216	CR254 + MYSLOT72
	54	da / from 90	a / to 216	CR254 + MYSLOT90

Per collezione / For collection

PLANETA

art.

H	P	L		
1,2	54	da / from 72	a / to 216	CR354 + MYSLOT72
	54	da / from 90	a / to 216	CR354 + MYSLOT90

Top con lavabo integrato in Corian spessore 12 mm, con sistema di scarico predisposto per sifone.
N.B. solo per porta lavabi H 37,5 e H 50 cm. Nei porta lavabi H 37,5 è possibile inserire solo sifone art. MICRO.

*Top with integrated sink completely in Corian 12 mm thick, with drain prepared for siphon.
P.S. only for sink units cm 37,5 and 50 H. In sink units cm 37,5 H it is only possible to use siphon art. MICRO.*



top / tops

Per collezione / For collection				
BESPOKE - PIANA - LUNARIA - TEMPRA				
H	P	L	art.	
1,2	54	da / from 144	a / to 299,4	CR154 + n° 2 MY SLOT72

Per collezione / For collection				
PANTA REI				
H	P	L	art.	
1,2	54	da / from 144	a / to 216	CR254 + n° 2 MY SLOT72

Per collezione / For collection				
PLANETA				
H	P	L	art.	
1,2	54	da / from 144	a / to 216	CR354 + n° 2 MY SLOT72

Top con doppio lavabo integrato in Corian spessore 12 mm, con sistema di scarico predisposto per sifone.

N.B. solo per porta lavabi H 37,5 e H 50 cm. Nei porta lavabi H 37,5 è possibile inserire solo sifone art. MICRO.

Top with double integrated sink completely in Corian 12 mm thick, with drain prepared for siphon.
P.S. only for sink units cm 37,5 and 50 H. In sink units cm 37,5 H it is only possible to use siphon art. MICRO.

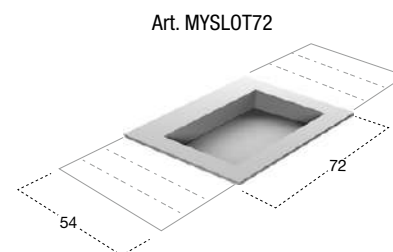

+

Art. CR154 - CR254 - CR354

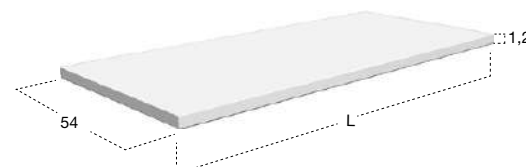



OPENSLOT design Nevio Tellatin

antoniolupi completa nel 2017 la trilogia del programma Slot, che nel 2001 ha ridefinito l'archetipo del lavabo trasformando la piletta da semplice componente funzionale in dettaglio estetico e tratto distintivo del progetto.

Già nel 2008, My-Slot aveva ampliato la versatilità del lavabo rendendolo disponibile anche con uno scarico tradizionale. In entrambi i casi l'utilizzo del Corian come unico materiale impiegato e la totale assenza della piletta e del troppopieno, descrivevano un'estetica minimale mai vista prima.

Le forme nitide ed essenziali, i volumi puliti e rigorosi, le linee rette e l'equilibrio proporzionale delle superfici, che sono nel dna del progetto, si ritrovano, dopo oltre 15 anni dal lancio di quello che è oggi un vero bestseller, anche nella nuova versione del lavabo.

Open-Slot è la proposta che propone uno scarico tradizionale ispezionabile come quello di un normalissimo lavabo, nascosto alla vista grazie a un carter di copertura removibile, sempre realizzato in Corian. Una soluzione che permette di preservare l'identità e l'immagine di Slot ma allo stesso tempo di rendere più semplici le operazioni di manutenzione e di pulizia di ogni sua parte.

In 2017, Antoniolupi completes the trilogy of the Slot series, which in 2001 redefined the archetype of the wash basin by transforming the drain from a simple functional component into aesthetic detail and distinctive feature of the project.

Already in 2008, My-Slot had expanded the versatility of the washbasin making it available with a traditional drain. In either case the use of Corian as the only material and the total absence of the drain and overflow, describes minimal aesthetics ever seen before.

Sharp and essential shapes, clean and rigorous volumes, straight lines and proportional balance of the surfaces, which are in the DNA of the project, are found, after more than 15 years since the launch of what is now a real bestseller, even in the new version.

Open-Slot is the proposal of a traditional drain inspection as that of a standard washbasin concealed by sight thanks to a removable cover, always made in Corian. A solution that preserves the identity and image of the Slot, but at the same time makes it easier to maintain and clean any part of it.





top / tops

Per collezione / For collection

BESPOKE - PIANA - LUNARIA - TEMPRA

art.

H	P	L		
1,2	54	da / from 72	a / to 299,4	CR154 + OPENSLOT72
	54	da / from 90	a / to 299,4	CR154 + OPENSLOT90
	54	da / from 108	a / to 299,4	CR154 + OPENSLOT108

Per collezione / For collection

PANTA REI

art.

H	P	L		
1,2	54	da / from 72	a / to 299,4	CR254 + OPENSLOT72
	54	da / from 90	a / to 299,4	CR254 + OPENSLOT90
	54	da / from 108	a / to 299,4	CR254 + OPENSLOT108

Per collezione / For collection

PLANETA

art.

H	P	L		
1,2	54	da / from 72	a / to 299,4	CR354 + OPENSLOT72
	54	da / from 90	a / to 299,4	CR354 + OPENSLOT90
	54	da / from 108	a / to 299,4	CR354 + OPENSLOT108

Top con lavabo integrato in Corian spessore 12 mm, completo di piletta con scarico libero e raccordo per sifone.

N.B. solo per porta lavabi H 37,5 e H 50 cm. Nei porta lavabi H 37,5 è possibile inserire solo sifone art. MICRO. Solo per rubinetteria a parete.

Top with integrated sink completely in Corian 12 mm thick, with drain pipe fitting and open plug.
P.S. only for sink units cm 37,5 and 50 H. In sink units cm 37,5 H it is only possible to use siphon art. MICRO. Only for wall mount tap.

Art. OPENSLOT72 - OPENSLOT90 - OPENSLOT108

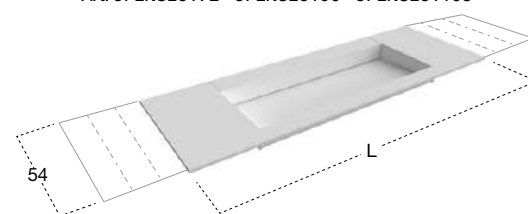

+

Art. CR154 - CR254 - CR354

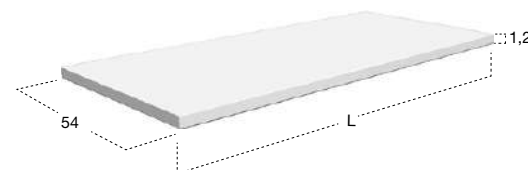





top / tops

Per collezione / For collection

BESPOKE - PIANA - LUNARIA - TEMPRA

art.

H	P	L		art.
1,2	54	da / from 72	a / to 299,4	CR154 + SEGN072
	54	da / from 90	a / to 299,4	CR154 + SEGN090

Per collezione / For collection

PANTA REI

art.

H	P	L		art.
1,2	54	da / from 72	a / to 216	CR254 + SEGN072
	54	da / from 90	a / to 216	CR254 + SEGN090

Per collezione / For collection

PLANETA

art.

H	P	L		art.
1,2	54	da / from 72	a / to 216	CR354 + SEGN072
	54	da / from 90	a / to 216	CR354 + SEGN090

Top con lavabo integrato in Corian spessore 12 mm, completo di piletta con scarico libero e raccordo per sifone.

N.B. solo per porta lavabi H 37,5 e H 50 cm. Nei porta lavabi H 37,5 è possibile inserire solo sifone art. MICRO.

Top with integrated sink completely in Corian 12 mm thick, with drain pipe fitting and open plug.
P.S. only for sink units cm 37,5 and 50 H. In sink units cm 37,5 H it is only possible to use siphon art. MICRO.

Art. SEGN072 - SEGN090

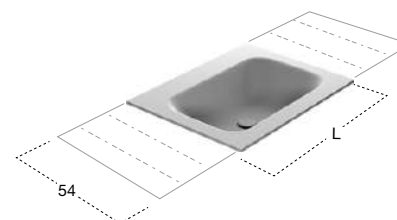

+

Art. CR154 - CR254 - CR354

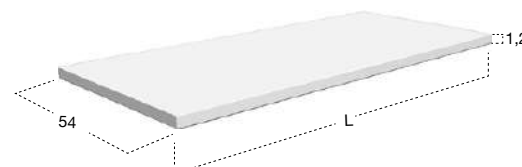

SEGNO



Art. SEGN072

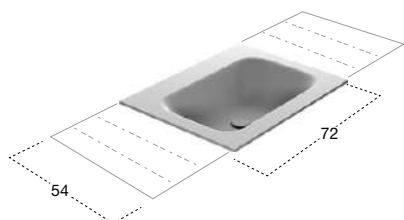

+

Art. CR154 - CR254 - CR354

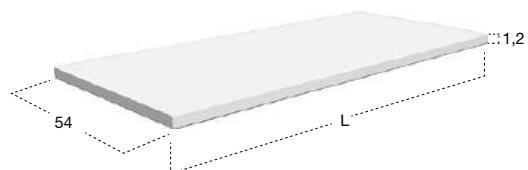

Per collezione / For collection

BESPOKE - PIANA - LUNARIA - TEMPRA

art.

H	P	L
1,2	54	da / from 144 a / to 299,4

CR154 + n° 2 SEGN072

Per collezione / For collection

PANTA REI

art.

H	P	L
1,2	54	da / from 144 a / to 216

CR254 + n° 2 SEGN072

Per collezione / For collection

PLANETA

art.

H	P	L
1,2	54	da / from 144 a / to 216

CR354 + n° 2 SEGN072

Top con doppio lavabo integrato in Corian spessore 12 mm, completo di piletta con scarico libero e raccordo per sifone.

N.B. solo per porta lavabi H 37,5 e H 50 cm. Nei porta lavabi H 37,5 è possibile inserire solo sifone art. MICRO.

Top with double integrated sink completely in Corian 12 mm thick, with drain pipe fitting and open plug.

P.S. only for sink units cm 37,5 and 50 H. In sink units cm 37,5 H it is only possible to use siphon art. MICRO.



top / tops

Per collezione / For collection				
BESPOKE - PIANA - LUNARIA - TEMPRA				
H	P	L	art.	
1,2	54	da / from 180	a / to 299,4	CR154 + n° 2 SEGNO90

Per collezione / For collection				
PANTA REI				
H	P	L	art.	
1,2	54	da / from 180	a / to 216	CR254 + n° 2 SEGNO90

Per collezione / For collection				
PLANETA				
H	P	L	art.	
1,2	54	da / from 180	a / to 216	CR354 + n° 2 SEGNO90

Top con doppio lavabo integrato in Corian spessore 12 mm, completo di piletta con scarico libero e raccordo per sifone.

N.B. solo per porta lavabi H 37,5 e H 50 cm. Nei porta lavabi H 37,5 è possibile inserire solo sifone art. MICRO.

Top with double integrated sink completely in Corian 12 mm thick, with drain pipe fitting and open plug. P.S. only for sink units cm 37,5 and 50 H. In sink units cm 37,5 H it is only possible to use siphon art. MICRO.

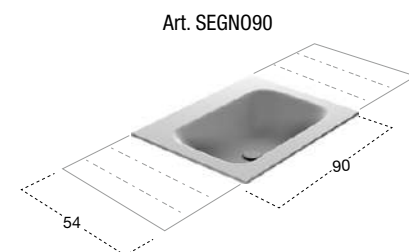

+

Art. CR154 - CR254 - CR354

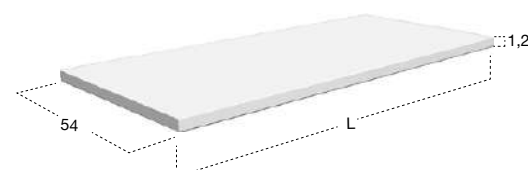



Art. ARC072 - ARC090

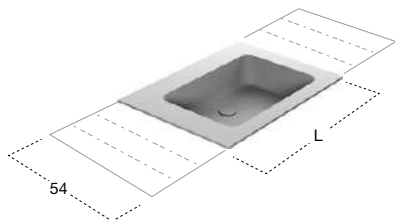

+

Art. CR154 - CR254 - CR354

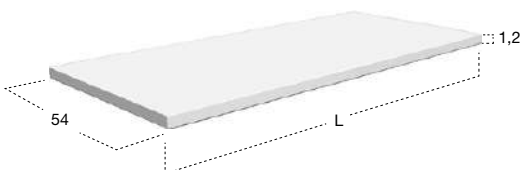

Per collezione / For collection

BESPOKE - PIANA - LUNARIA - TEMPRA

art.

H	P	L			
1,2	54	da / from 72	a / to 299,4	CR154 + ARC072	
	54	da / from 90	a / to 299,4	CR154 + ARC090	

Per collezione / For collection

PANTA REI

art.

H	P	L			
1,2	54	da / from 72	a / to 216	CR254 + ARC072	
	54	da / from 90	a / to 216	CR254 + ARC090	

Per collezione / For collection

PLANETA

art.

H	P	L			
1,2	54	da / from 72	a / to 216	CR354 + ARC072	
	54	da / from 90	a / to 216	CR354 + ARC090	

Top con lavabo integrato in Corian spessore 12 mm, completo di piletta con scarico libero e raccordo per sifone.
N.B. solo per porta lavabi H 37,5 e H 50 cm. Nei porta lavabi H 37,5 è possibile inserire solo sifone art. MICRO.

*Top with integrated sink completely in Corian 12 mm thick, with drain pipe fitting and open plug.
P.S. only for sink units cm 37,5 and 50 H. In sink units cm 37,5 H it is only possible to use siphon art. MICRO.*



top / tops

Per collezione / For collection				
BESPOKE - PIANA - LUNARIA - TEMPRA				
H	P	L	art.	
1,2	54	da / from 144	a / to 299,4	CR154 + n° 2 ARC072

Per collezione / For collection				
PANTA REI				
H	P	L	art.	
1,2	54	da / from 144	a / to 216	CR254 + n° 2 ARC072

Per collezione / For collection				
PLANETA				
H	P	L	art.	
1,2	54	da / from 144	a / to 216	CR354 + n° 2 ARC072

Top con doppio lavabo integrato in Corian spessore 12 mm, completo di piletta con scarico libero e raccordo per sifone.

N.B. solo per porta lavabi H 37,5 e H 50 cm. Nei porta lavabi H 37,5 è possibile inserire solo sifone art. MICRO.

Top with double integrated sink completely in Corian 12 mm thick, with drain pipe fitting and open plug. P.S. only for sink units cm 37,5 and 50 H. In sink units cm 37,5 H it is only possible to use siphon art. MICRO.

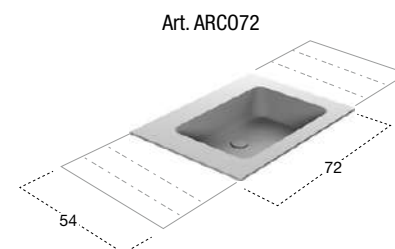

+

Art. CR154 - CR254 - CR354

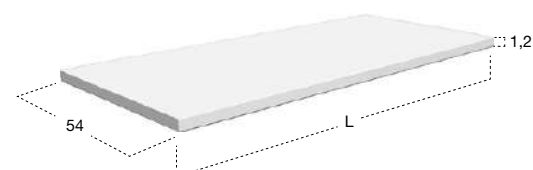





top / tops



Art. OPENSLOT72 - OPENSLOT90 - OPENSLOT108

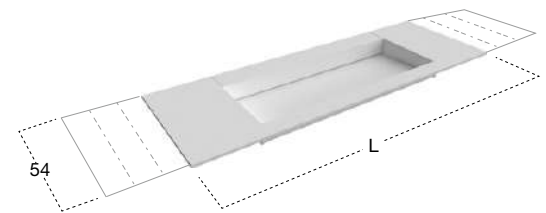

+

Art. CRS54

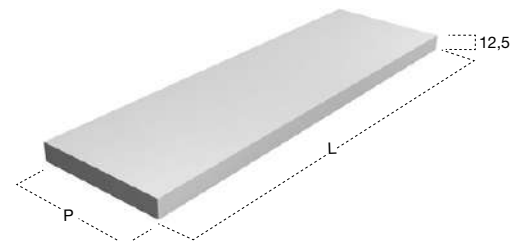

H	P	L			art.
12,5	54	da / from 72	a / to 299,4		CRS54 + OPENSLOT72
	54	da / from 90	a / to 299,4		CRS54 + OPENSLOT90
	54	da / from 108	a / to 299,4		CRS54 + OPENSLOT108

Top con lavabo integrato sopra piano o da parete in Corian spessore 125 mm, completo di piletta con scarico libero e raccordo per sifone.

N.B. solo per rubinetteria a parete.

Top with integrated sink completely in Corian 125 mm thick complete with drain pipe fitting and open plug which may be wall mounted or used on furniture.

P.S. only for wall mount tap.





top / tops

Art. MYSLLOT472 - MYSLLOT490 - MYSLLOT72 - MYSLLOT90

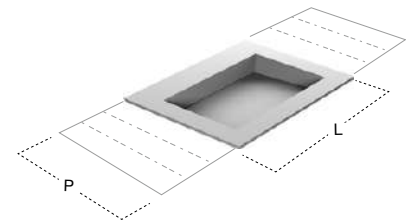

+

Art. CRS40 - CRS54

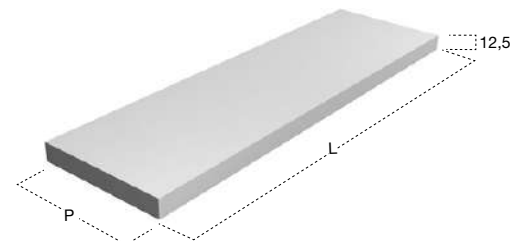

H	P	L			art.
12,5	40	da / from 72	a / to 299,4		CRS40 + MYSLLOT472
	40	da / from 90	a / to 299,4		CRS40 + MYSLLOT490

H	P	L			art.
12,5	54	da / from 72	a / to 299,4		CRS54 + MYSLLOT72
	54	da / from 90	a / to 299,4		CRS54 + MYSLLOT90

Top con lavabo integrato in Corian, spess. 125 mm con sistema di scarico predisposto per sifone.

Top with integrated sink completely in Corian 125 mm thick with drain prepared for siphon that can be wall mounted or used on furniture.





top / tops

Art. MYSLOT72

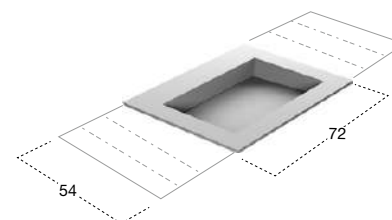

+

Art. CRS54

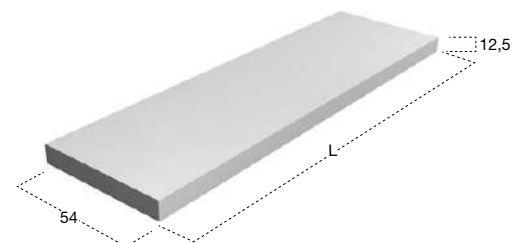

H	P	L	art.	
12,5	54	da / from 144	a / to 299,4	CRS54 + n° 2 MYSLOT72

Top con doppio lavabo integrato in Corian, spess. 125 mm con sistema di scarico predisposto per sifone.

Top with double integrated sinks completely in Corian 125 mm thick with drain prepared for siphon that can be wall mounted or used on furniture.



SLOT design Nevio Tellatin

Ha cambiato il modo di concepire il lavabo, ha ridefinito l'archetipo di un suo componente meramente funzionale trasformandolo in strumento compositivo del progetto, ha sancito l'inizio di un nuovo percorso, quello del minimalismo assoluto.

Pulito, essenziale, rigoroso, moderno. In una sola parola Slot. Il Corian come materiale d'elezione con il suo uniforme candore e la setosa superficie da toccare, il disegno come regola da seguire. Forme nette, linee squadrate, spigoli vivi e ampiezza dei bordi ma soprattutto totale assenza della piletta, del troppopieno, di tutto ciò che in qualche modo può offuscare la perfetta estetica dell'oggetto. Rimane una fessura, un taglio nella parte posteriore del bacino, un'apertura sottile che corre lungo tutto lo sviluppo del lavabo e accoglie l'acqua grazie all'impercettibile inclinazione del fondo, nascondendo alla vista il sifone integrato. Le parti tecniche sono invisibili, l'acqua defluisce lungo una scanalatura lineare, l'immagine del lavabo rimane pulita, assoluta, essenziale.

A different way of conceiving a sink redefining the archetype of its purely functional component of the project, transforming it into a compositional tool, marks the beginning of a new path, that of absolute minimalism.

Clean, essential, rigorous, modern. In one word Slot. Corian as a material of choice with its uniform whiteness and silky surface to touch, such as the design rule to follow. Net shapes, square lines, sharp edges and width of the borders but total absence of drain, overflow, of all that can somehow confuse the perfect aesthetics of the object. It remains a slit, a cut in the rear part of the basin, a thin opening that runs along the whole development of the basin and accommodates the water through the imperceptible inclination of the bottom, hiding the integrated siphon. The technical parts are invisible, water flows along a linear slot, the sink image remains clean, absolute, essential.



top / tops

Art. SLOT

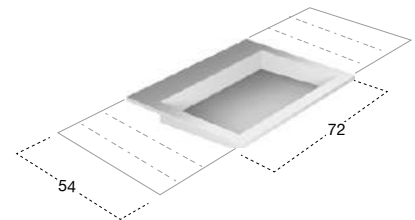

+

Art. CRS15

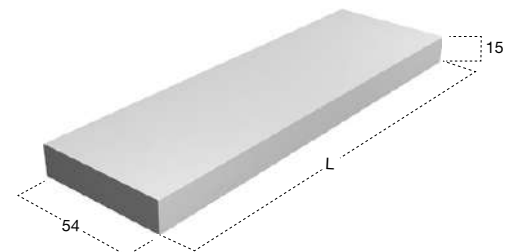

H	P	L	art.	
15	54	da / from 72	a / to 299,4	CRS15 + SLOT

Top con lavabo integrato in Corian spess. 150 mm, con sifone incorporato.

Top with integrated sink in Corian 150 mm thick with incorporated trap which may be wall mounted or used on furniture.





top / tops

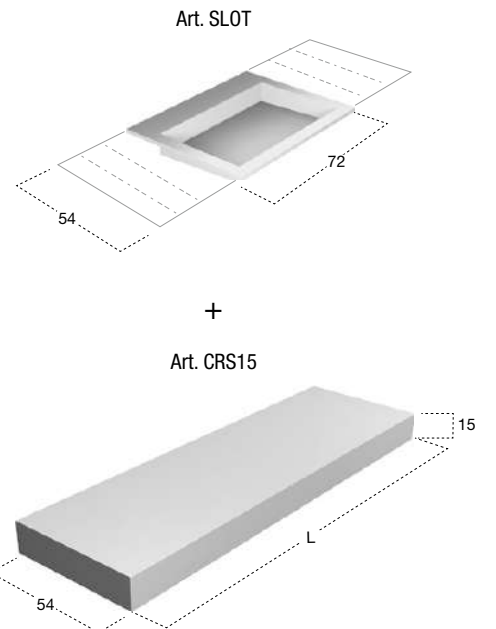

H	P	L			art.
15	54	da / from 144	a / to 299,4		CRS15 + n° 2 SLOT

Top con doppio lavabo integrato in Corian, spess. 150 mm, con sifone incorporato.

Top with double integrated sinks completely in Corian 150 mm thick with incorporated trap which may be wall mounted or used on furniture.



Art. SEGN072 - SEGN090

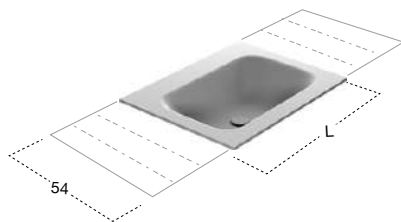

+

Art. CRS54

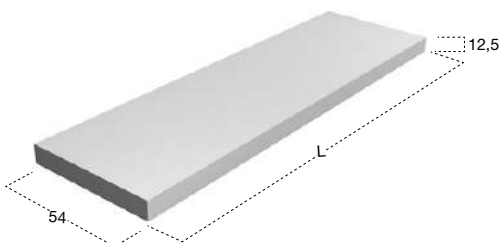

H	P	L	art.	
12,5	54	da / from 72	a / to 299,4	CRS54 + SEGN072
	54	da / from 90	a / to 299,4	CRS54 + SEGN090

Top con lavabo integrato sopra piano o da parete in Corian spessore 125 mm, completo di piletta con scarico libero e raccordo per sifone.

Top with integrated sink completely in Corian 125 mm thick complete with drain pipe fitting and open plug which may be wall mounted or used on furniture.



top / tops

Art. SEGN072 - SEGN090

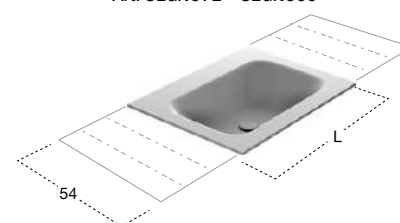

+

Art. CRS54

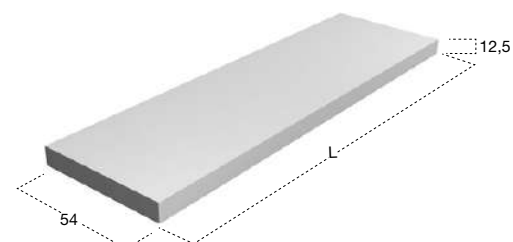

H	P	L			art.
12,5	54	da / from 144	a / to 299,4		CRS54 + n° 2 SEGN072
	54	da / from 180	a / to 299,4		CRS54 + n° 2 SEGN090

Top con doppio lavabo integrato sopra piano o da parete in Corian spessore 125 mm, completo di piletta con scarico libero e raccordo per sifone.

Top with double integrated sink completely in Corian 125 mm thick complete with drain pipe fitting and open plug which may be wall mounted or used on furniture.



Art. ARC072 - ARC090

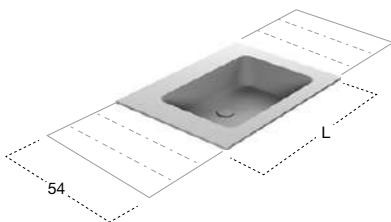

+
Art. CRS54

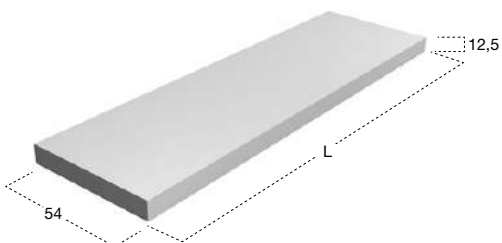

H	P	L			art.
12,5	54	da / from 72	a / to 299,4		CRS54 + ARC072
	54	da / from 90	a / to 299,4		CRS54 + ARC090

Top con lavabo integrato sopra piano o da parete in Corian spessore 125 mm, completo di piletta con scarico libero e raccordo per sifone.

Top with integrated sink completely in Corian 125 mm thick complete with drain pipe fitting and open plug which may be wall mounted or used on furniture.



top / tops

H	P	L	art.	
12,5	54	da / from 144	a / to 299,4	CRS54 + n° 2 ARC072

Top con doppio lavabo integrato sopra piano o da parete in Corian spessore 125 mm, completo di piletta con scarico libero e raccordo per sifone.

Top with double integrated sink completely in Corian 125 mm thick complete with drain pipe fitting and open plug which may be wall mounted or used on furniture.

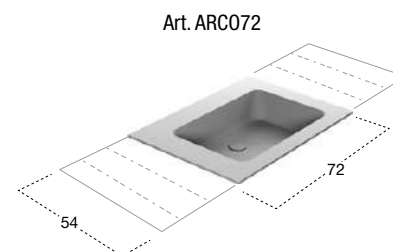

+
Art. CRS54

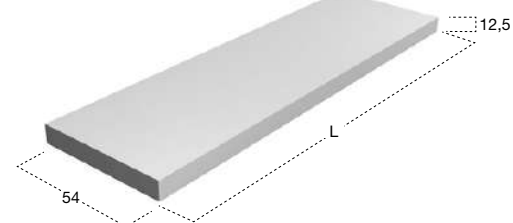





top / tops

rovere thermo



rovere evaporato



top / tops

rovere thermo

I top scatolati sono realizzati con multistrato di betulla finlandese ad incollaggio fenolico con impiallacciatura in Rovere Evaporato spazzolato 4 mm e in Rovere Thermo o Noce Canaletto in 6 decimi.

Boxy tops are made of Finnish Birch plywood with phenolic adhesives veneered with 4 mm Rovere Evaporato and 6-tenths Rovere Thermo or Noce Canaletto.

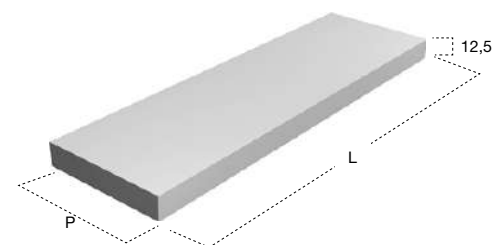

H	P	L	art.
12,5	40	da / from 54 a / to 299,4	BANCO140
	47		BANCO147
	54		BANCO154

Top scatolare in legno spessore 125 mm.

Suspended wood top, 125 mm thick.



LAVABI / SINKS



lavabi / sinks

CALICE design Domenico De Palo e Mario Ferrarini

Modello e design registrato, brevetto depositato
Registered model and design, patent filed

Una forma appena accennata che nasce dal sapiente controllo della forza dirompente del segno, un volume leggero che morbidamente fuoriesce dalla parete per inoltrarsi sinuosamente nello spazio, un riferimento esplicito a un'immagine classica reinterpretata attraverso un materiale contemporaneo grazie al quale conferire assoluta continuità alla superficie.

Il racconto del magico incontro tra spazio e materia si arricchisce di un nuovo episodio. Dopo Strappo, Silenzio e Soffio prosegue la ricerca di antoniolupi sul tema dell'integrazione tra lavabo e parete, sulla possibilità di dare continuità alla superficie verticale per descrivere un bacino che accoglie l'acqua in uno spazio fluido e avvolgente. Con Calice, la tradizionale scansione del lavabo a colonna viene sviluppata con eleganza e pulizia formale per una collezione in grado ancora una volta di emozionare.

L'equilibrio dei volumi, le profondità di colonna e bacino, il perfetto raccordo tra le parti. Un progetto di armonia e dialogo fra gli elementi, un insieme di raccordi assoluti e curve calibrate, un confronto tra naturale e artificiale, tra organicità e disegno architettonico che danno vita a un oggetto prezioso, un calice in Corian, che nobilita l'acqua che contiene.

A form that is born from the clever control of the disruptive force of the sign, a light volume that softly emerges from the wall to sinuously enter space, an explicit reference to a classical image reinterpreted through a contemporary material to give absolute continuity to the surface. The story of the magical encounter between space and matter is enriched with a new episode. After Strappo, Silenzio and Soffio research continues for antoniolupi on the theme of integration between sink and wall, on the ability to give continuity to the vertical surface in order to describe a basin that welcomes water in a fluid and enveloping space. With Calice, the traditional sink is developed with elegance and formal cleansing for a collection that can once again thrill.

The balance of the volumes, the depths of the column and basin, the perfect connection between the parts. A project of harmony and dialogue between the elements, a set of absolute joints and calibrated curves, a comparison between natural and artificial, between organic and architectural design that give birth to a precious object, a glass in Corian, which enhances the water that it contains.



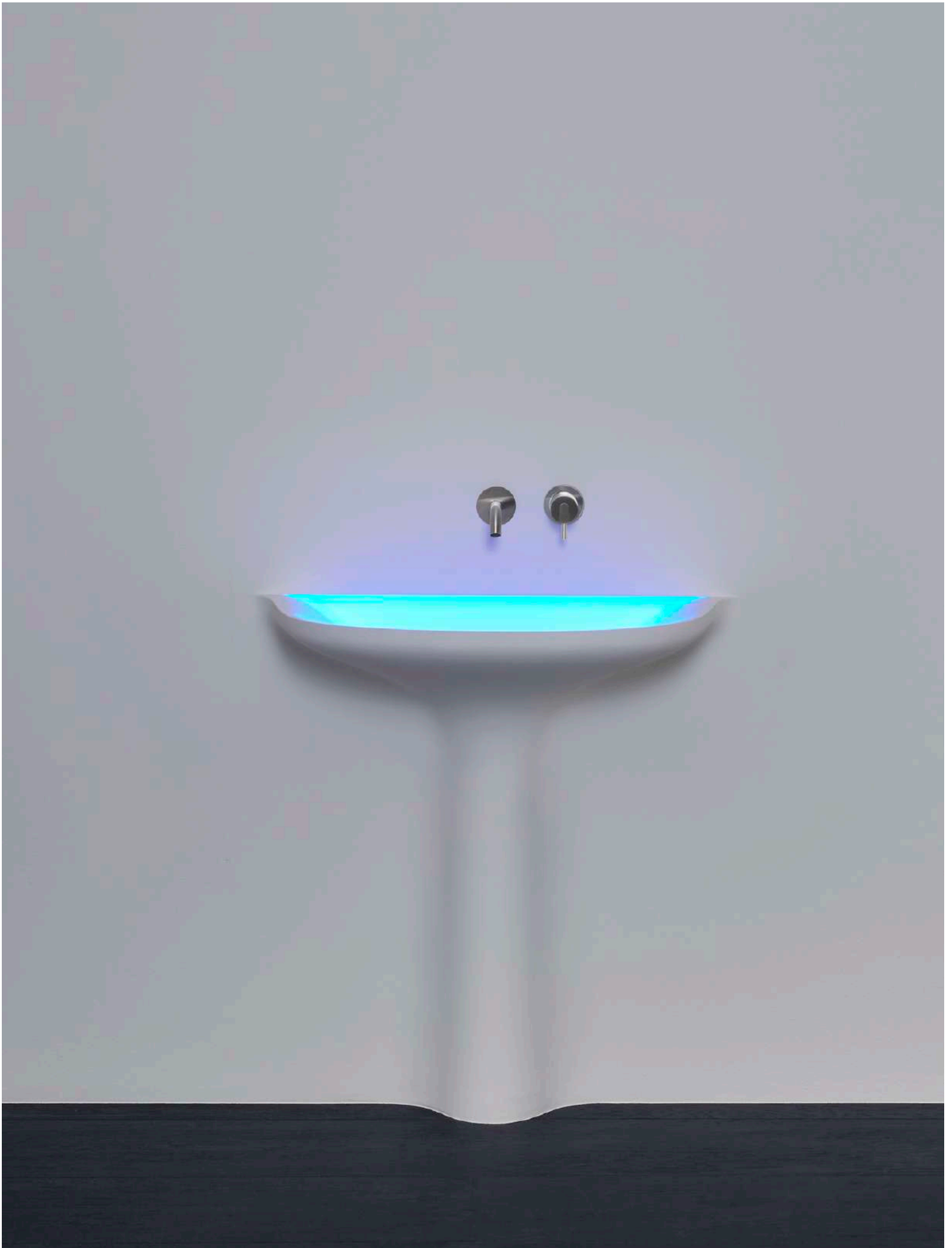

lavabi / sinks





lavabi / sinks

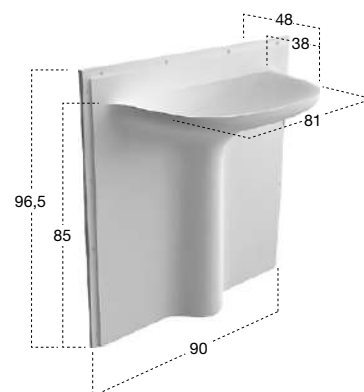

H	P	L	art.	art.
96,5	48	90	CALICE	CALICEL Con illuminazione a led / With led lighting

Lavabo da incasso a parete in Corian, con o senza illuminazione a led, completo di piletta ispezionabile, sifone e tubo flessibile.

Encased Corian sink with or without led lighting, complete with inspectable drain, trap and flexible hose.

STRAPPO design Domenico De Palo

Modello e design registrato, brevetto depositato
Registered model and design, patent filed

Un lembo della parete che si strappa generando rumore, un foglio sottile che viene "tirato fuori dal muro" e rivela uno spazio nascosto, celato alla vista, nel quale è ospitato il lavabo. L'essenza in un gesto, quello dello strappo, del prendere una parte della parete e tirarla con forza rivelando con sorpresa ciò che vi è nascosto dietro. Strappo è il lavabo integrato che nasce dalla trasposizione di un'azione, che sembra voler uscire dal muro ma che allo stesso tempo si mimetizza nella parete, senza apparire in tutta la sua forma a una prima vista frontale ma svelando tutto se stesso solo dopo una visione laterale.

Strappo è realizzato interamente in Corian e può essere integrato perfettamente nella parete perché dopo essere stato installato può essere stuccato e rifinito con lo stesso materiale e colore di cui è composta la superficie muraria. Al contrario può essere valorizzato per contrasto definendo un campo di colore diverso da quello della parete. L'illuminazione led contribuisce ad accrescere la magia e a valorizzare la sensazione di fluido movimento, anche se generato da un'azione repentina, che è nel dna di questo scenografico lavabo.

A thin sheet that is "pulled out of the wall" and reveals a hidden space, hidden from sight, which houses the sink.

The essence in a gesture, that of a tear, taking a part of the wall and pulling it tight, surprisingly revealing what is hidden behind. Strappo is the integrated sink that comes from the implementation of an action, which seems to come out from the wall but at the same time blends within, without appearing in all its forms at a first front view but revealing all of itself only after viewing it from the side.

Strappo is made entirely in Corian and can perfectly be integrated in the wall because after installation can be stuccoed and finished with the same material and colour as the wall. It can also be enhanced if painted a different colour from the wall. The led lighting contributes to enhance the magic and the feeling of fluid movement even if generated by sudden action which is in the DNA of this sink.



COLORI / COLOURS

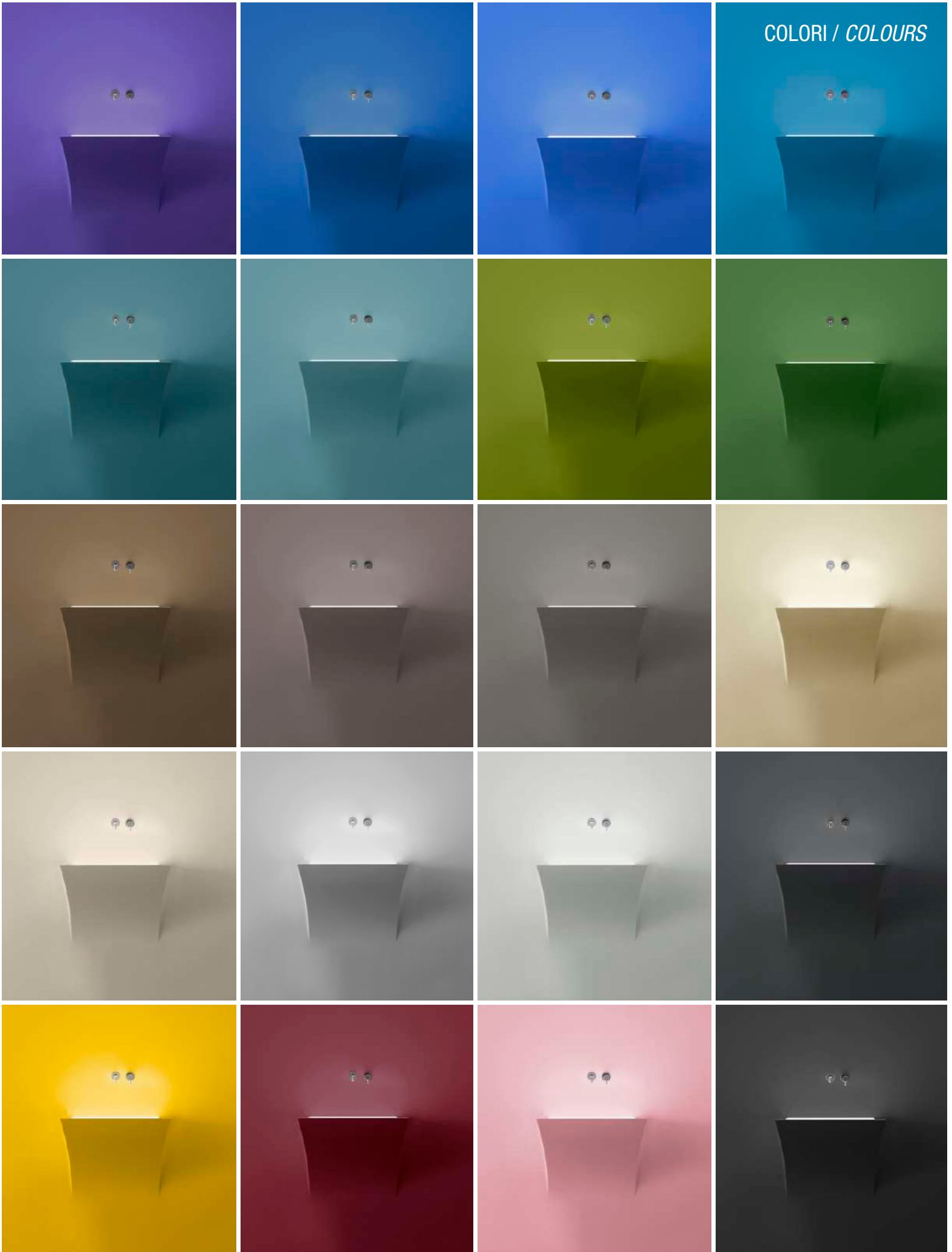

lavabi / sinks





lavabi / sinks

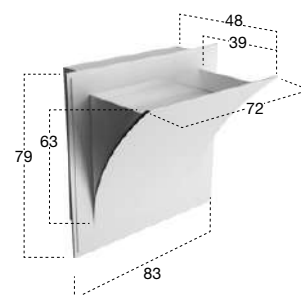

H	P	L	art.	art.
79	48	83	STRAPPO	STRAPPOL Con illuminazione a led / With led lighting

Lavabo da incasso a parete in Corian, con o senza illuminazione a led, completo di piletta ispezionabile, sifone e tubo flessibile.

Encased Corian sink with or without led lighting, complete with inspectable drain, trap and flexible hose.

STRAPPO



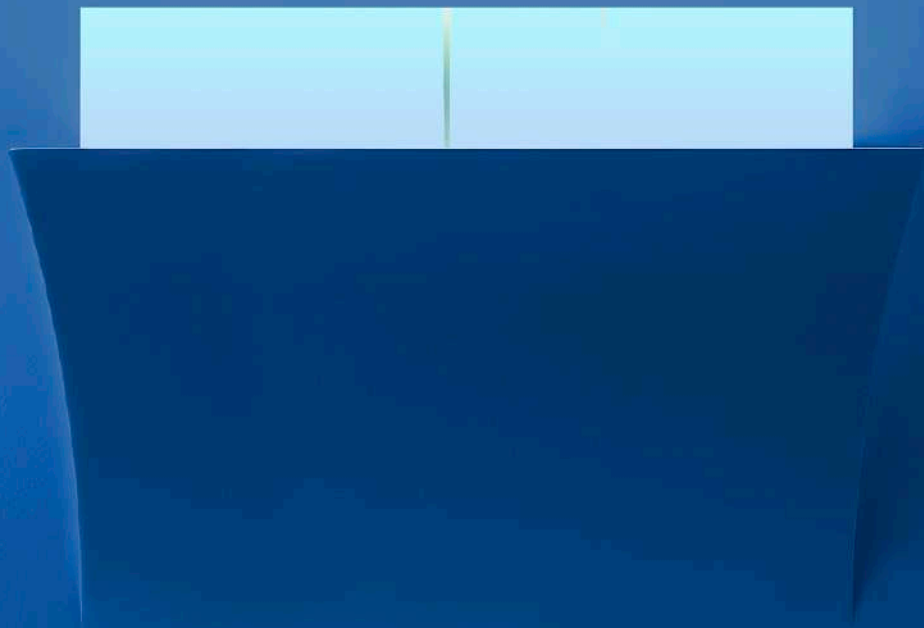





lavabi / sinks

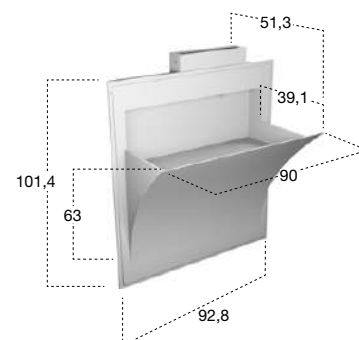

H	P	L	art.	art.
101,4	51,3	92,8	STRAPPOXL	STRAPPOXLL Con illuminazione a led / With led lighting

Lavabo da incasso a parete in Corian, con o senza illuminazione a led, completo di rubinetteria, piletta ispezionabile, sifone e tubo flessibile.

Encased Corian sink with or without led lighting, complete with tap, inspectable drain, trap and flexible hose.

SILENZIO design Domenico De Palo

Modello e design registrato, brevetto depositato
Registered model and design, patent filed

Un gesto scultoreo e delicato, un segno generatore, una morbida sinuosità che fuoriesce dalla parete; in sintesi un taglio e una luce, quali unici elementi della composizione. La funzionalità diventa oggetto inedito, esclusivo. Il ruolo del bacino, quello del contenere definisce l'aspetto finale del lavabo attraverso una forma organica che accoglie l'acqua che sgorga come una sorgente dalla parete. Silenzio è un lavabo integrato che diventa tutt'uno con la parete stessa, è un taglio di luce che sottolinea un andamento sinuoso, descrive un gesto creativo, da cui tutto ha origine. Un lavabo nudo, realizzato interamente in Corian e poi integrato perfettamente nella parete nella quale si mimetizza al meglio quando vengono usati lo stesso rivestimento e gli stessi colori per completarlo. Il movimento sinuoso viene enfatizzato dalla perfezione della finitura e dall'assoluta continuità del rivestimento che lascia al colore il ruolo di protagonista e alla luce il compito di esaltarne e di segnalare che qualcosa di magico sta accadendo oltre la superficie.

A sculptural and delicate gesture that comes out of the wall; in summary a cut and a light the essential elements of the composition.

Function becomes an unusual and exclusive object. The role of the basin defines the final aspect through an organic form that welcomes water that comes from the wall. Silenzio is an integrated sink that becomes one with the wall, it is a cut of light the underlines a sinuous course, it describes a creative gesture from which everything originates.

A bare sink made entirely in Corian and then seamlessly integrated in the wall which blends best when the same material and colours as the wall are used to complete it. The sinuous movement can be emphasized with the perfection of the finish and absolute continuity of the coating that leaves colour as the lead player and light the role to exalt it showing that something magical is happening.





lavabi / sinks

SILENZIO









lavabi / sinks

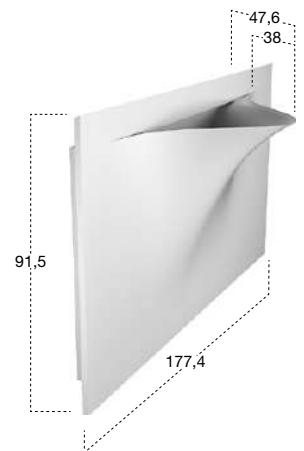

H	P	L	art.	art.
91,5	47,6	177,4	SILENZIO	SILENZIOL Con illuminazione a led / With led lighting

Lavabo da incasso a parete in Corian, con o senza illuminazione a led, completo di piletta ispezionabile, sifone e tubo flessibile.

Encased Corian sink with or without led lighting, complete with inspectable drain, trap and flexible hose.



SOFFIO design Domenico De Palo

Modello e design registrato, brevetto depositato
Registered model and design, patent filed

Un gesto delicato per descrivere l'essenza stessa del lavabo a muro, una perfetta fusione tra forme morbide e lineari, un soffio leggero che modella la materia dandole nuova forma.

Nasce dalla sintesi tra Strappo e Silenzio, definendo al meglio la simbiosi di questi lavabi con la parete dalla quale vengono generati. Soffio viene originato da una leggera folata di vento che delicatamente trasforma la superficie. Senza la forza di Strappo, senza l'organicità di Silenzio ma riproponendo un'immagine più conosciuta, seppur inedita nella sua creazione e concezione.

Soffio affianca i modelli Strappo e Silenzio nel filone di ricerca di antoniolupi legato a una perfetta fusione tra l'oggetto, lo spazio e gli elementi architettonici che lo definiscono. In particolare l'integrazione di lavabi, accessori e camini nella parete è espressione della volontà di nascondere l'intervento artificiale dell'uomo lasciando all'acqua e al fuoco il ruolo di veri protagonisti del rito che si rinnova.

A delicate gesture to describe the essence of the sink, a perfect fusion between soft and linear shapes a slight wind that molds matter giving it a new shape.

Born from the synthesis between Strappo and Silenzio defining the best symbiosis of these basins with the wall from which they are generated. Soffio is originated by a light gust of wind that delicately transforms the surface. Without the force of Strappo, without the organic shape of Silenzio but proposing a more known image. Soffio joins the models Strappo and Silenzio in the line of research of antoniolupi tied to a perfect fusion between the object, the space and the architectural elements that define it. In particular the integration of sinks, accessories and chimneys in the wall are an expression of the will to hide the artificial intervention of man leaving water and fire the role of true protagonist.



lavabi / sinks





lavabi / sinks

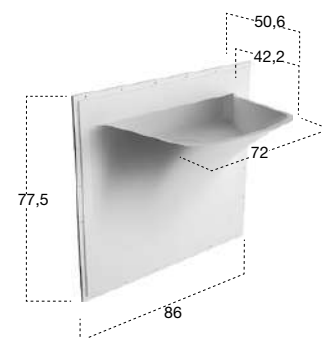

H	P	L	art.	art.
77,5	50,6	86	SOFFIO	SOFFIOL Con illuminazione a led / With led lighting

Lavabo da incasso a parete in Corian, con o senza illuminazione a led, completo di piletta ispezionabile, sifone e tubo flessibile.

Encased Corian sink with or without led lighting, complete with inspectable drain, trap and flexible hose.

Dans toutes les choses de la nature il y a quelque chose de merveilleux

Aristotele

BATTIGIA, la merveille d'un lavabo inspiré par la nature.



BATTIGIA design Michel Boucquillon

Modello e design registrato, brevetto depositato

Registered model and design, patent filed

Battigia, è un nuovo lavabo in Corian, che continua e sviluppa la serie di lavabi "nascosti", che sono una peculiarità della produzione antoniolupi. In questo caso, l'unica cosa che fuoriesce dal muro, è una lastra in vetro inclinata (che può essere realizzata anche in marmo), mentre anche la rubinetteria scompare, celata nel vano della parete. Nella struttura interna, è integrata anche l'illuminazione a led con luce bianca e blu, che crea un effetto di grande suggestione. Quando il rubinetto è aperto e l'acqua scende, si ha l'impressione di un fenomeno naturale, una piccola cascata, il mare che si infrange sulla riva. Come gli altri lavabi incassati, anche Battigia può essere rivestito come si desidera, stuccato, intonacato, e verniciato.

Disponibile in cinque misure: 90, 108, 126, 144 e 180 cm, a richiesta può essere realizzato anche su misura.

Battigia is a new sink in Corian, that extends and develops the series of "hidden" sinks which are a peculiarity of the antoniolupi production. In this case, the only thing that protrudes from the wall is a sheet of inclined glass (that can also be made of marble) while the tap is hidden in the wall compartment. White and blue LED lighting is integrated in the structure creating an effect of great beauty. When the tap is open and the water falls one gets the impression of natural phenomenon, a small cascade or the sea breaking on the shore. As the other encased sinks Battigia can also be covered as one wishes, stuccoed, plastered and painted.

Available in five lengths; 90,108,126,144 and 180 cm upon request can be made to measure.



BATTIGIA

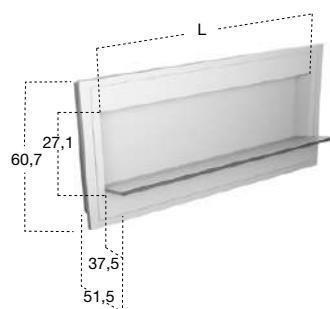

H	P	L	art.	art.
60,7	51,5	?	BATTIGIA	BATTIGIAL Con illuminazione a led / With led lighting

Lavabo da incasso a parete in Corian, con o senza illuminazione a led, completo di rubinetteria piletta ispezionabile, sifone e tubo flessibile, con lastra in cristallo extrachiaro o cristallo acidato.
(L 90, 108, 126, 144, 180 cm)

*Encased Corian sink with or without led lighting, complete with tap, inspectable drain, siphon and flexible hose. Available with extra-clear or acid glass surface.
(L 90, 108, 126, 144, 180 cm)*



lavabi / sinks

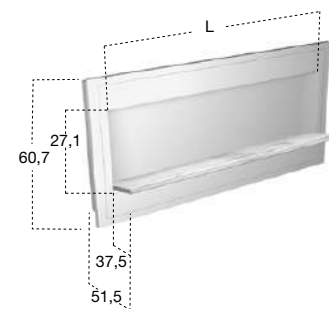

H	P	L	art.	art.
60,7	51,5	?	BATTIGIAM	BATTIGIAML Con illuminazione a led / With led lighting

Lavabo da incasso a parete in Corian, con o senza illuminazione a led, completo di rubinetteria piletta ispezionabile, sifone e tubo flessibile, con lastra in marmo Carrara.
(L 90, 108, 126, 144, 180 cm)

*Encased Corian sink with or without led lighting, complete with tap, inspectable drain, siphon and flexible hose, with Carrara marble surface.
(L 90, 108, 126, 144, 180 cm)*





CANALE design Carlo Colombo

Modello e design registrato, brevetto depositato
Registered model and design, patent filed

Un elemento tecnico che diventa componente espressiva, un dettaglio che identifica una collezione tanto da condizionarne il nome, un progetto che riassume le potenzialità infinite di un'azienda. Canale è il simbolo dell'approccio sartoriale di antoniolupi all'ambiente bagno, è un lavabo a parete realizzato interamente in Flumood, che si sviluppa in larghezza secondo le specifiche esigenze del cliente in un intervallo compreso tra 90 e 216 cm.

Le forme sono squadrate, nette e rigorose, lo sviluppo longitudinale è nel dna del prodotto, gli spessori sono contenuti grazie all'evoluzione tecnologica e all'impiego di questo straordinario materiale, la capienza del bacino è molto elevata. Il lavabo Canale unisce estetica e funzionalità proprio grazie al "canale" che è in realtà una comoda base d'appoggio rialzata sulla quale riporre accessori e tutto quanto è necessario per lo svolgimento delle azioni quotidiane nell'area lavabo.

A technical element that becomes an expressive component, a detail that identifies a collection so much as to affect the name, a project that summarizes the infinite potential of a company. Canale is the tailored approach, symbol of antoniolupi's bathroom environments, it is a wall-mounted washbasin made entirely in Flumood, which develops in width according to the specific needs of the client in a range between 90 and 216 cm.

The shapes are square, sharp and rigid, the longitudinal development is in the DNA of the product, the thicknesses are contained due to improved technology and the use of this extraordinary material, the capacity of the basin is very high. The basin Canale combines aesthetics and functionality thanks to the actual "channel" that it is, a convenient surface on which to store accessories and everything necessary for everyday usage.





lavabi / sinks

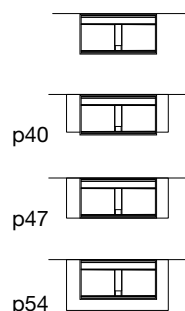

H	P	L	art.
5	33	20	PIANETTO

Pianetto optional copripiletta in Flumood finitura Satin.

Optional Flumood drain cover in satin finish.

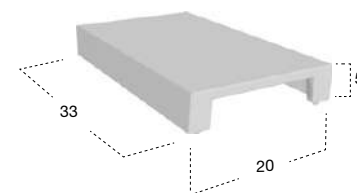

H	P	L	art.
12,5	47	?	CANALE

Lavabo rettangolare sopraiano o da parete in Flumood, completo di piletta con scarico libero e raccordo per sifone.
(L da 90 cm a 216 cm)

Rectangular top mount or wall mount Flumood sink, complete with drain pipe fitting and open plug.
(L from 90 to 216 cm)

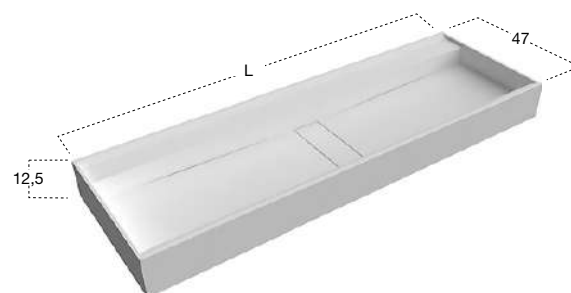

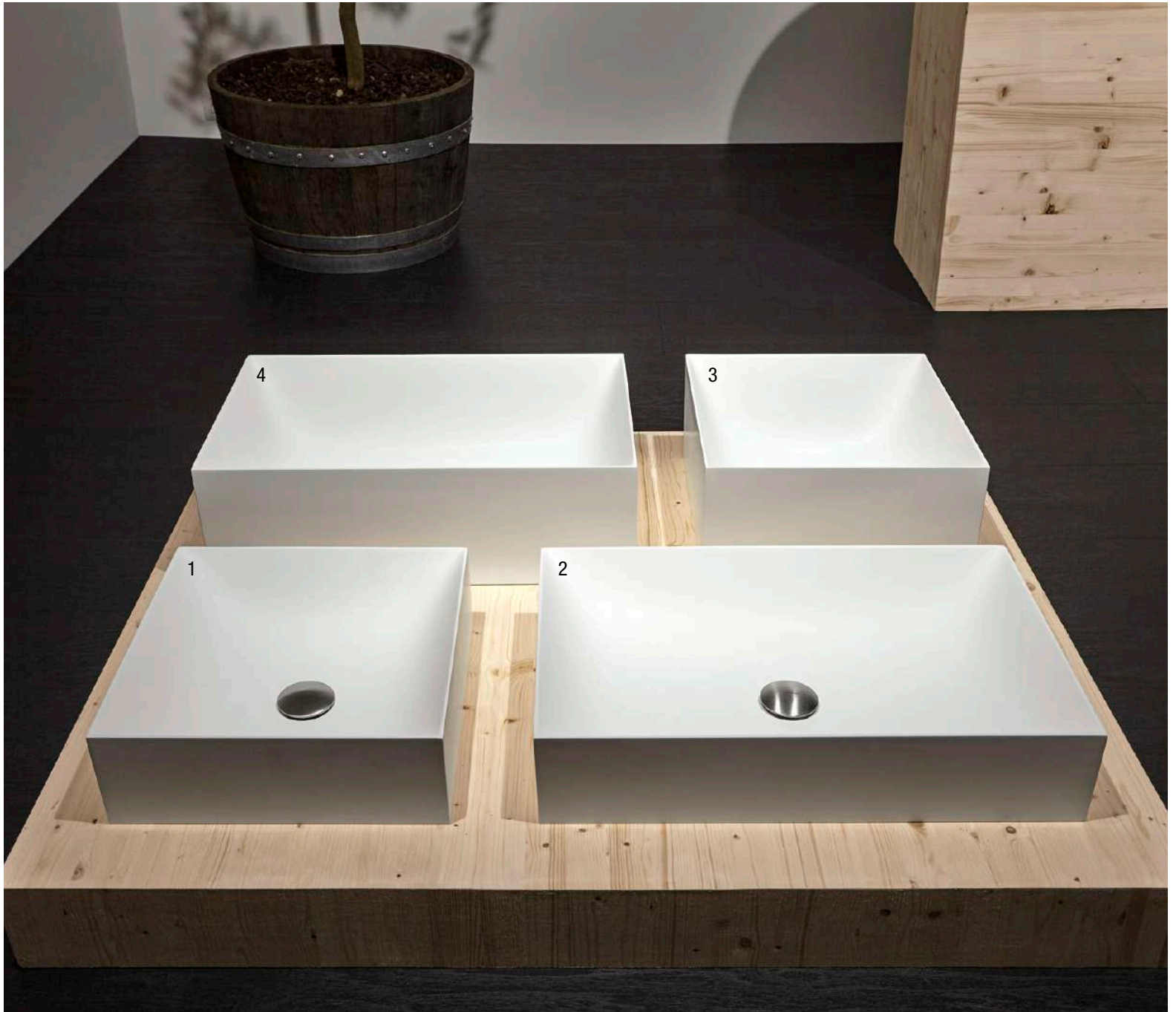

- | | | |
|---|---------------|---------------------|
| 1 | Art. STRATOS1 | H 12,5 P 40 L 40 cm |
| 2 | Art. STRATOS2 | H 12,5 P 40 L 63 cm |
| 3 | Art. STRATOS3 | H 18,8 P 40 L 40 cm |
| 4 | Art. STRATOS4 | H 18,8 P 40 L 63 cm |

STRATOS design Mario Ferrarini

Le linee nette e le geometrie rigorose del volume esterno si addolciscono nella morbida fluidità del bacino. Stratos è una commistione di due anime che si integrano in modo elegante in un'immagine armonica, è un perimetro rigido che esprime sicurezza e solidità proteggendo una superficie organica che si sviluppa al suo interno e si estende senza soluzione di continuità.

Una forma scultorea, un volume idealmente scavato dalla forza primordiale dell'acqua. Stratos è un lavabo realizzato in Flumood, il materiale brevettato da antoniolupi, e disponibile nella forma quadrata o rettangolare in due diverse altezze (12,5 e 18,8 cm). Stratos può essere appoggiato su un piano o sospeso a parete.

The sharp lines and the rigorous external geometrical shapes are softened with the fluidness of the internal shape of the basin. Stratos is a mixture of two souls integrated in an elegant and harmonious manner. It's rigid perimeter expresses safety and solidity protecting an organic interior that extends without interruption.

A sculptural shape, a volume ideally dug from the primordial force of water. Stratos is a washbasin made in Flumood, material patented by antoniolupi, and available in a square or rectangular shape in two different heights (12,5 and 18,8 cm). Stratos can be top mounted or wall mounted.



lavabi / sinks

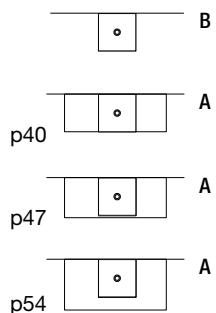

Verniciabile esternamente in tutti i colori del nostro campionario
 Can be externally lacquered in all colors of our collection

H	P	L	art.
12,5	40	40	STRATOS1

Lavabo quadrato sopra piano (A) o da parete (B) in Flumood, completo di piletta con scarico libero e raccordo per sifone.

Square top mount (A) or wall (B) mount Flumood sink, complete with drain pipe fitting and open plug.

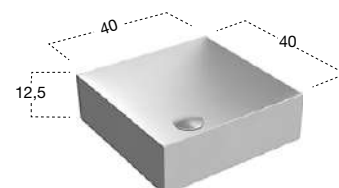

STRATOS



Verniciabile esternamente in tutti i colori del nostro campionario
Can be externally lacquered in all colors of our collection

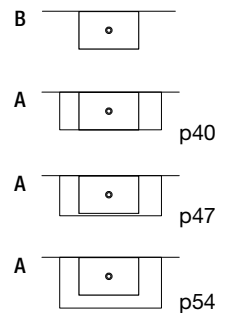
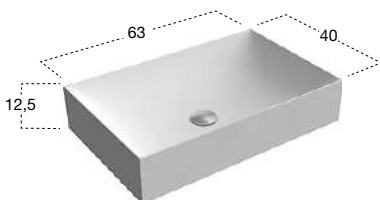

H	P	L	art.
12,5	40	63	STRATOS2

Lavabo rettangolare sopra piano (A) o da parete (B) in Flumood, completo di piletta con scarico libero e raccordo per sifone.

Rectangular top mount (A) or wall mount (B) Flumood sink, complete with drain pipe fitting and open plug.



lavabi / sinks

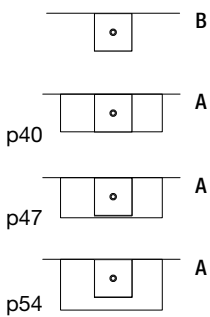

Verniciabile esternamente in tutti i colori del nostro campionario
Can be externally lacquered in all colors of our collection

H	P	L	art.
18,8	40	40	STRATOS3

Lavabo quadrato sopra piano (A) o da parete (B) in Flumood, completo di piletta con scarico libero e raccordo per sifone.

Square top mount (A) or wall mount (B) Flumood sink, complete with drain pipe fitting and open plug.

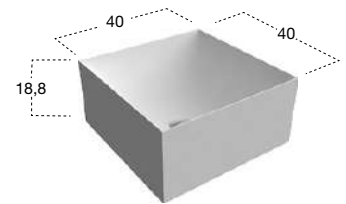

STRATOS



Verniciabile esternamente in tutti i colori del nostro campionario
Can be externally lacquered in all colors of our collection

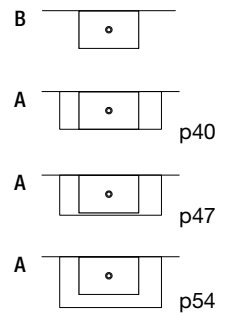
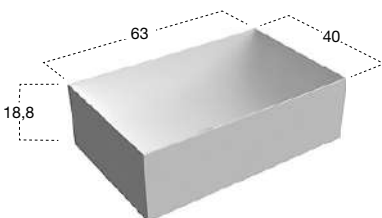

H	P	L	art.
18,8	40	63	STRATOS4

Lavabo rettangolare sopra piano (A) o da parete (B) in Flumood, completo di piletta con scarico libero e raccordo per sifone.

Rectangular top mount (A) or wall mount (B) Flumood sink, complete with drain pipe fitting and open plug.



lavabi / sinks

STRATOS1

L 40 P 40 H 12,5

STRATOS3

L 40 P 40 H 18,8



STRATOS2

L 63 P 40 H 12,5

STRATOS4

L 63 P 40 H 18,8



lavabi / sinks

STRATOS1





lavabi / sinks

SIMPLO design Mario Ferrarini

Modello e design registrato, brevetto depositato
Registered model and design, patent filed

Eleganti nel perfetto equilibrio delle proporzioni, minimali nella definizione complessiva della forma ma allo stesso tempo organici: i Simplo sono perfetti nell'interpretare attraverso i bordi sottili e gli angoli curvi, le ultime tendenze in materia di interior design e di progettazione di elementi che compongono l'ambiente bagno. La sottigliezza dei bordi permette inoltre di sfruttare al massimo la capacità del bacino, mentre il comodo piano d'appoggio, amplifica la funzionalità del lavabo e del lavamani. I Simplo sono realizzati interamente in Flumood. Il lavamani può essere appeso a parete o appoggiato su un piccolo mobile e può trovare posto all'interno di nicchie, vani o bagni di servizio.

Elegant in their perfectly balanced proportions, minimal in their overall definition of form but at the same time organic: the Simplo basins are perfect in interpreting thin edges and curved corners, the latest trends in interior design and elements of design that make up the bathroom environment. The subtle edges allow you to take advantage of the full capacity of the basins, while the comfortable surface amplifies their functionality. Simplo are made entirely in Flumood. These washbasins can be hung on the wall or top mounted on a small cabinet and can find a place in niches or guest bathrooms.









lavabi / sinks

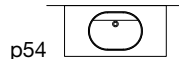
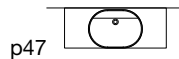
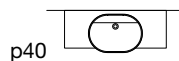

Verniciabile esternamente in tutti i colori del nostro campionario
Can be externally lacquered in all colors of our collection

H	P	L	art.
11,3	45	63	SIMPLOVALE

Lavabo ovale sopra piano in Flumood, completo di piletta con scarico libero e raccordo per sifone.

Oval top mount Flumood sink, complete with drain pipe fitting and open plug.



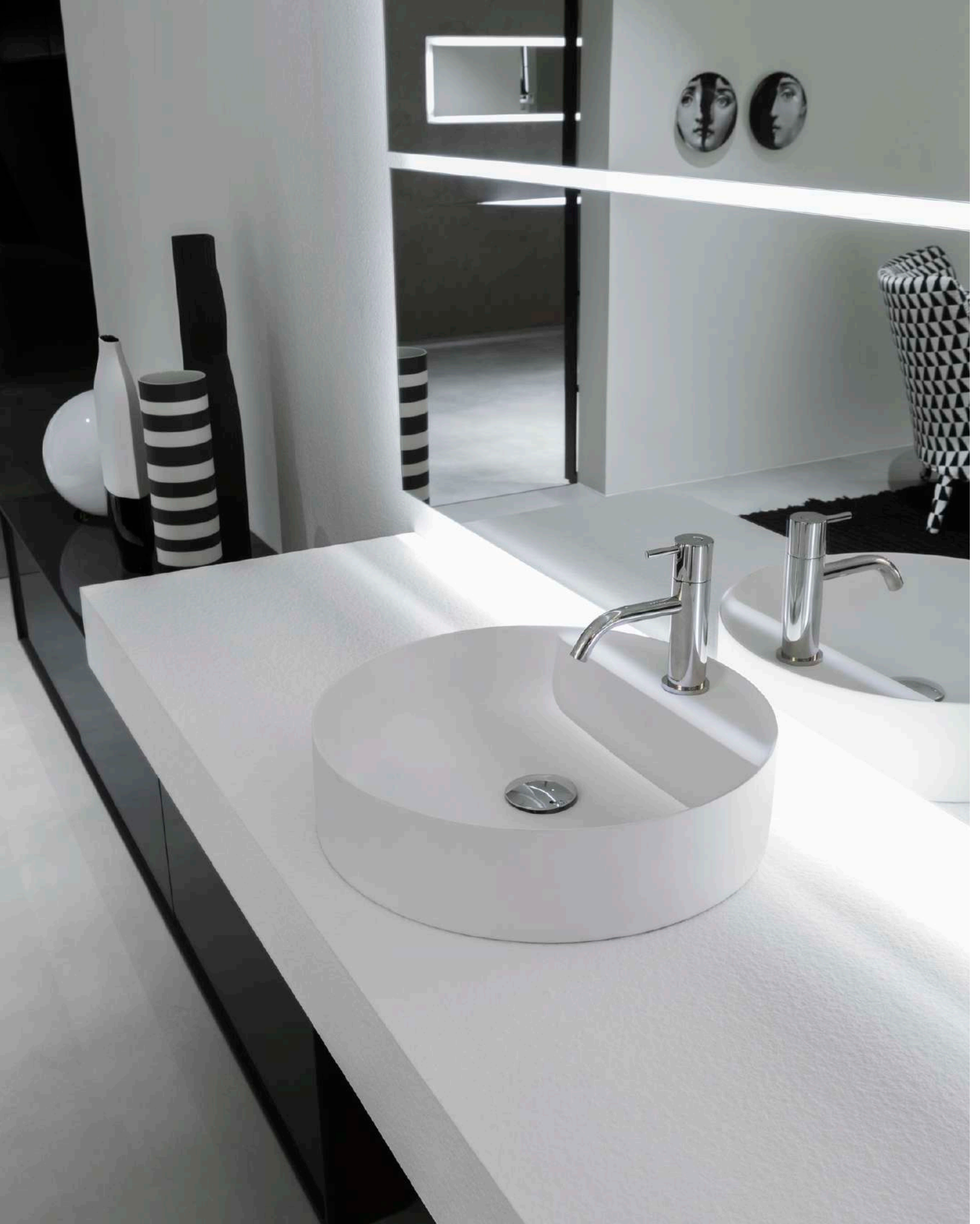



lavabi / sinks

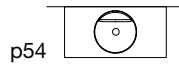
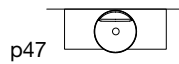
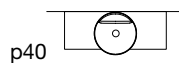

Verniciabile esternamente in tutti i colori del nostro campionario
Can be externally lacquered in all colors of our collection



H	Ø	art.
11	45	SIMPLOTONDO

Lavabo tondo sopra piano in Flumood completo di piletta con scarico libero e raccordo per sifone.

Round top mount Flumood sink complete with drain pipe fitting and open plug.

SIMPLO





lavabi / sinks





lavabi / sinks

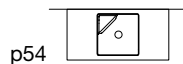
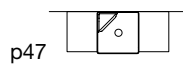
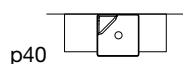

Verniciabile esternamente in tutti i colori del nostro campionario
Can be externally lacquered in all colors of our collection

H	P	L	art.
11	42	42	SIMPL042

Lavabo quadrato sopra piano dx o sx in Flumood completo di piletta con scarico libero e raccordo per sifone.

Right or left hand square top mount Flumood sink complete with drain pipe fitting and open plug.







lavabi / sinks

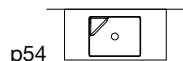
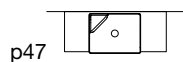
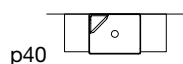

Verniciabile esternamente in tutti i colori del nostro campionario
Can be externally lacquered in all colors of our collection

H	P	L	art.
11	42	54	SIMPL054

Lavabo rettangolare sopraiano in Flumood completo di piletta con scarico libero e raccordo per sifone.

Rectangular top mount Flumood sink complete with drain pipe fitting and open plug.

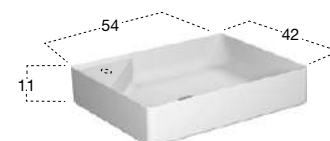





lavabi / sinks

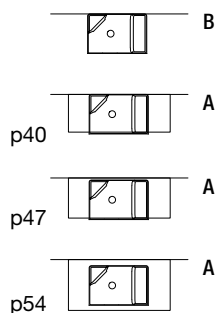

Verniciabile esternamente in tutti i colori del nostro campionario
 Can be externally lacquered in all colors of our collection

H	P	L	art.
11	42	63	SIMPL063

Lavabo rettangolare sopra piano (A) o da parete (B) in Flumood completo di piletta con scarico libero e raccordo per sifone.

Rectangular top mount (A) or wall mount (B) Flumood sink complete with drain pipe fitting and open plug.







lavabi / sinks

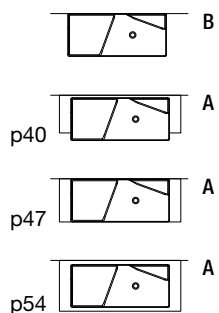

Verniciabile esternamente in tutti i colori del nostro campionario
 Can be externally lacquered in all colors of our collection

H	P	L	art.
11	47	108	SIMPL0108

Lavabo rettangolare sopra piano (A) o da parete (B) in Flumood completo di piletta con scarico libero e raccordo per sifone.

Rectangular top mount (A) or wall mount (B) Flumood sink complete with drain pipe fitting and open plug.

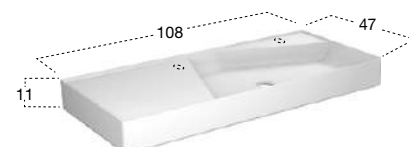

SIMPL054 + SMPI154





lavabi / sinks

SIMPL063 + SMP1163





lavabi / sinks

SIMPL0108 + SMPI1108



* Verniciabile esternamente in tutti i colori del nostro campionario
Can be externally lacquered in all colors of our collection

SIMPL042 + SMPI5142

H	P	L	art.
11	42	42	SIMPL042 *

Lavabo quadrato sopra piano dx o sx in Flumood completo di piletta con scarico libero e raccordo per sifone.

Right or left hand square top mount Flumood sink complete with drain pipe fitting and open plug.

H	P	L	art.
37,5	42	42	SMPI5142

Porta lavabo dx o sx con 1 anta, abbinabile solo con lavabo Art. SIMPL042.

Right or left single door sink unit to be combined with Art. SIMPL042

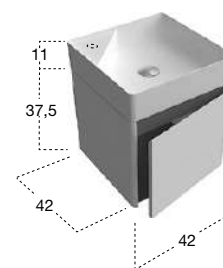

SIMPL054 + SMPI154

H	P	L	art.
11	42	54	SIMPL054 *

Lavabo rettangolare sopra piano in Flumood completo di piletta con scarico libero e raccordo per sifone.

Rectangular top mount Flumood sink complete with drain pipe fitting and open plug.

H	P	L	art.
37,5	42	54	SMPI154

Porta lavabo con 1 cassetto Art. SLIM, abbinabile solo con lavabo Art. SIMPL054.

Sink unit with 1 drawer Art. SLIM to be combined with Art. SIMPL054.

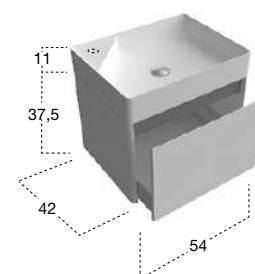

SIMPL063 + SMPI163

H	P	L	art.
11	42	63	SIMPL063 *

Lavabo rettangolare sopra piano in Flumood completo di piletta con scarico libero e raccordo per sifone.

Rectangular top mount Flumood sink complete with drain pipe fitting and open plug.

H	P	L	art.
37,5	42	63	SMPI163

Porta lavabo con 1 cassetto Art. SLIM, abbinabile solo con lavabo Art. SIMPL063.

Sink unit with 1 drawer Art. SLIM to be combined with Art. SIMPL063.

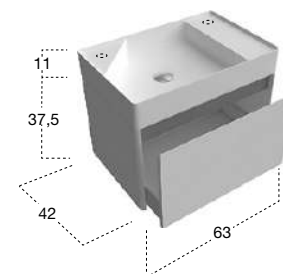

SIMPL0108 + SMPI1108

H	P	L	art.
11	47	108	SIMPL0108 *

Lavabo rettangolare sopra piano in Flumood completo di piletta con scarico libero e raccordo per sifone.

Rectangular top mount Flumood sink complete with drain pipe fitting and open plug.

H	P	L	art.
37,5	47	108	SMPI1108

Porta lavabo con 1 cassetto Art. SLIM, abbinabile solo con lavabo Art. SIMPL0108.

Sink unit with 1 drawer Art. SLIM to be combined with Art. SIMPL0108.

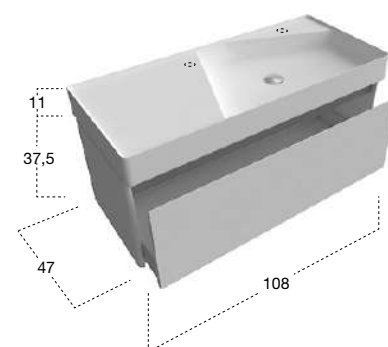





lavabi / sinks



* Verniciabile esternamente in tutti i colori del nostro campionario
 Can be externally lacquered in all colors of our collection

H	P	L	art.
11	25	45	SIMPLOMANI *

Lavabo rettangolare sopra piano o da parete in Flumood, completo di piletta con scarico libero e raccordo per sifone.

Rectangular top mount or wall mount Flumood sink, complete with drain pipe fitting and open plug.

H	P	L	art.
50	25	45	SIMPLOMANI *

Porta lavabo dx o sx con 1 anta e 1 ripiano interno, abbinabile solo con lavabo Art. SIMPLOMANI versione A e C.

Right or left single door sink unit with 1 internal shelf to be combined with Art. SIMPLOMANI in version A and C.

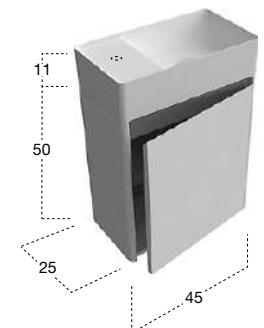



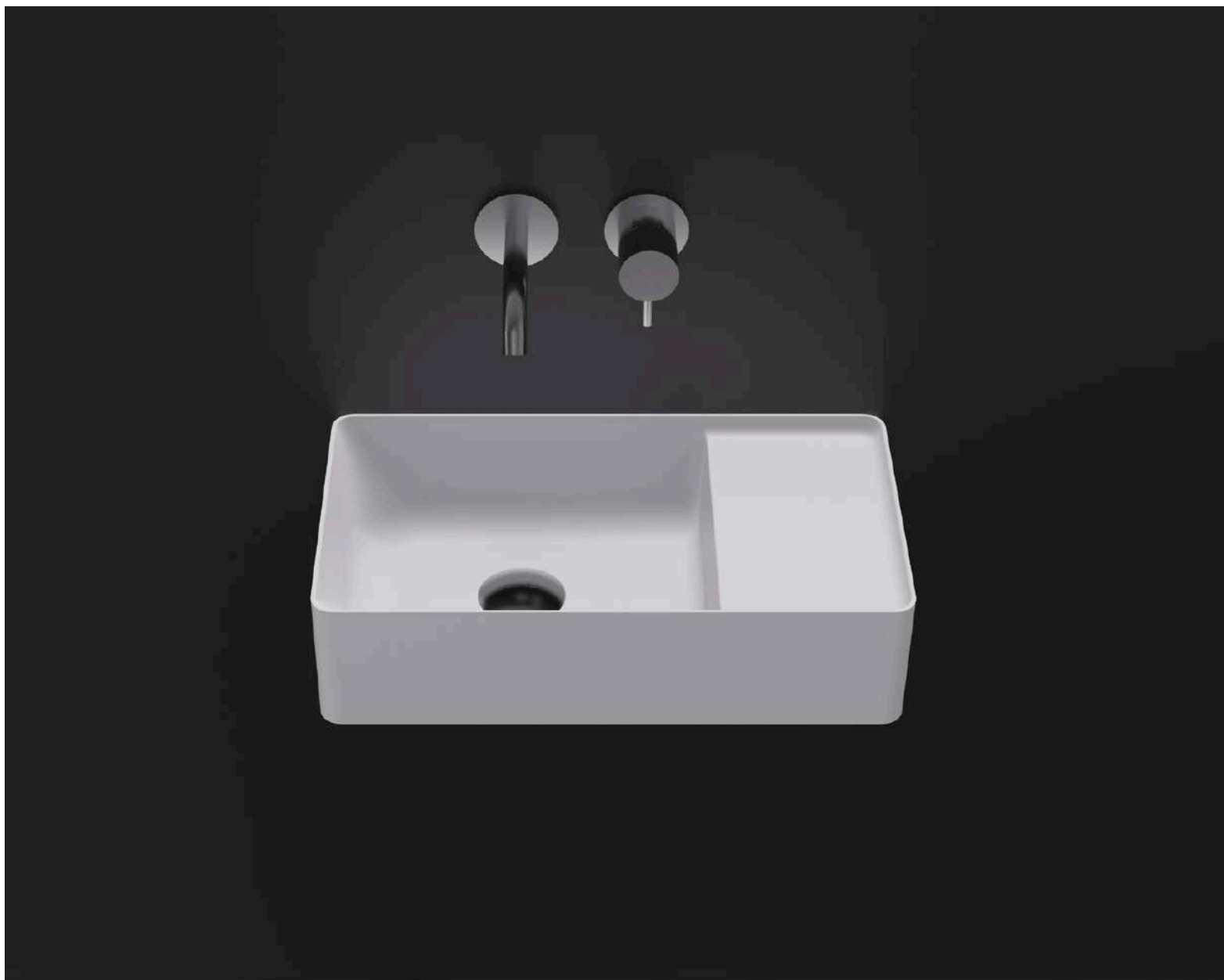

lavabi / sinks

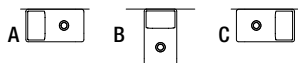

Verniciabile esternamente in tutti i colori del nostro campionario
Can be externally lacquered in all colors of our collection

H	P	L	art.
11	25	45	SIMPLOMANI

Lavabo rettangolare sopra piano o da parete in Flumood, completo di piletta con scarico libero e raccordo per sifone.

Rectangular top mount or wall mount Flumood sink, complete with drain pipe fitting and open plug.

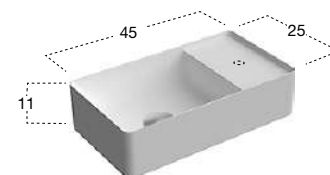





lavabi / sinks

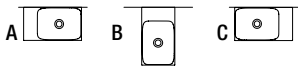

H	P	L	art.
25	25	45	CALCO

Lavabo rettangolare da parete in Flumood finitura texture completo di piletta con scarico libero e raccordo per sifone.

Rectangular wall mount Flumood texture sink, complete with drain pipe fitting and open plug.

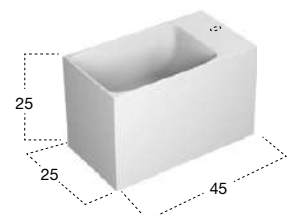



VENERE design Mario Ferrarini

La sensualità della forma, la morbidezza delle linee avvolgenti, la continuità delle superfici, il fascino che diventa mistero, il conosciuto che nasconde l'ignoto.

Non poteva che chiamarsi Venere e rimandare in modo esplicito al concetto di bellezza, di grazia, di sensualità tutta femminile. L'immagine frontale del lavabo sospeso, rimanda immediatamente a quella di una bocca, la superficie vellutata del Flumood, amplifica i sensi coinvolgendo la tattilità oltre che la vista. Venere è magicamente ancorato alla parete, è perfettamente integrato con essa grazie alla parte posteriore del bacino che risale per coprire le componenti tecnologiche d'ancoraggio.

The sensuality of form, the softness of the enveloping lines, the continuity of the surfaces, the charm that becomes mystery, what is known hides the unknown.

It could only be called Venere (Venus) and postpones explicitly to the concept of beauty, grace and feminine sensuality. The front image of the suspended washbasin leads immediately to that of a mouth, the smooth surface of the Flumood amplifies the senses involving tact over sight. VENERE is magically anchored to the wall, it is perfectly integrated with it through the back that comes up to cover the support components.



lavabi / sinks



H	P	L	art.
18,2	53,2	72,4	VENERE

Lavabo ovale da parete in Flumood, completo di piletta con scarico libero e raccordo per sifone.

Oval wall mount Flumood sink, complete with drain pipe fitting and open plug.

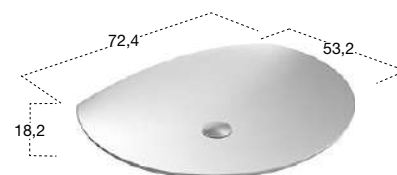

VENERE





lavabi / sinks





lavabi / sinks

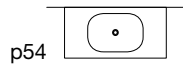
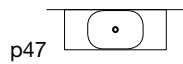
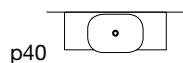

H	P	L	art.
15	40	60	SENSO

Lavabo rettangolare sopraiano in Flumood completo di piletta con scarico libero e raccordo per sifone.

Rectangular top mount Flumood sink complete with drain pipe fitting and open plug.



SENSO





lavabi / sinks

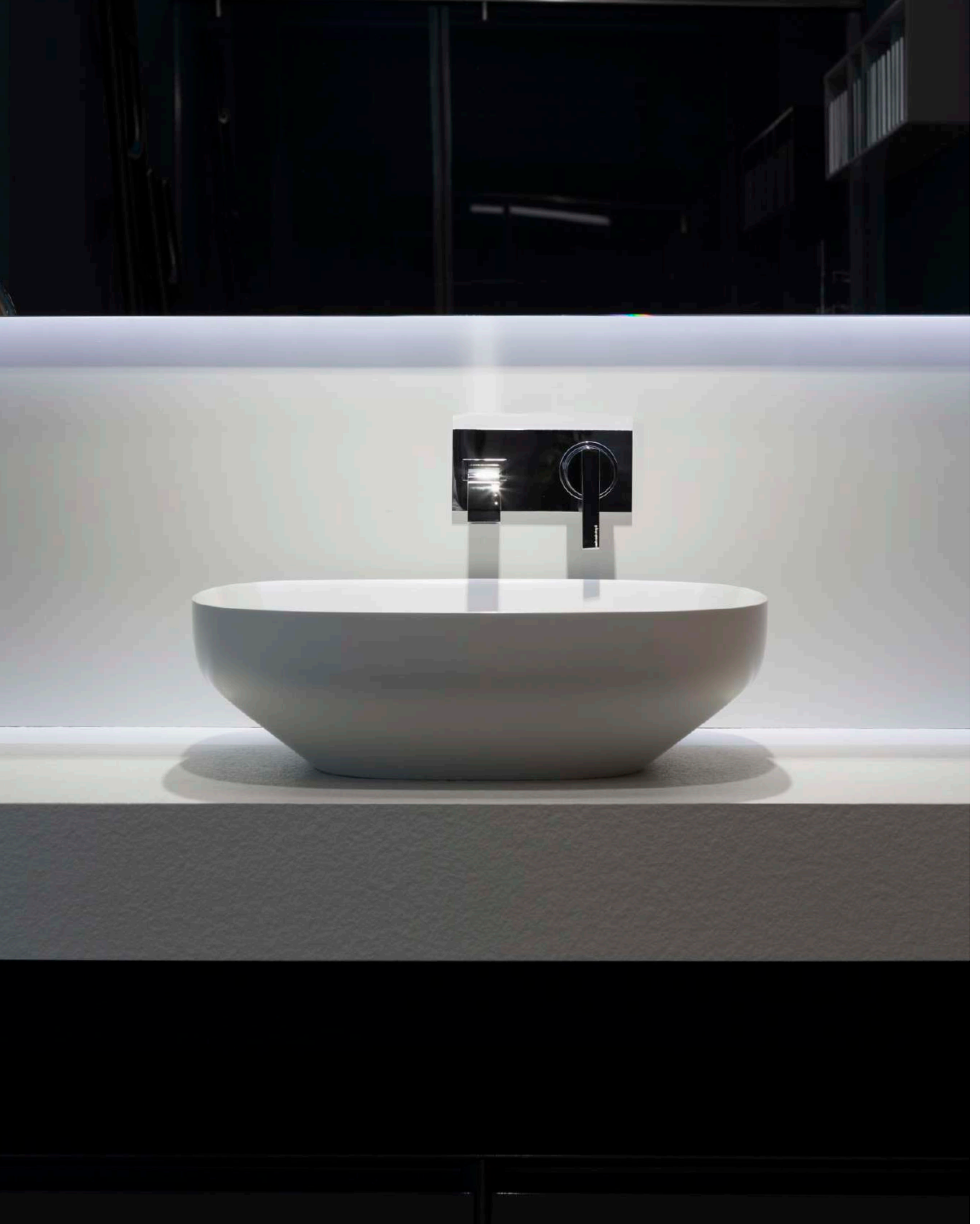



lavabi / sinks

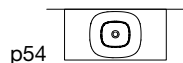
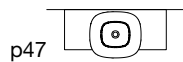
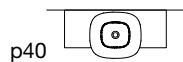

Verniciabile esternamente in tutti i colori del nostro campionario
Can be externally lacquered in all colors of our collection

H	P	L	art.
15	45	50	AG03

Lavabo ovale sopraiano in Flumood completo di piletta con scarico libero e raccordo per sifone.

Oval top mount Flumood sink complete with drain pipe fitting and open plug.



AGO





lavabi / sinks





lavabi / sinks

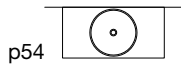
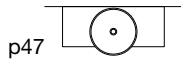
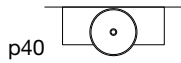

Verniciabile esternamente in tutti i colori del nostro campionario
Can be externally lacquered in all colors of our collection

H	Ø	art.
12	50	VERSO

Lavabo tondo sopraiano in Flumood completo di piletta con scarico libero e raccordo per sifone.

Round top mount Flumood sink complete with drain pipe fitting and open plug.

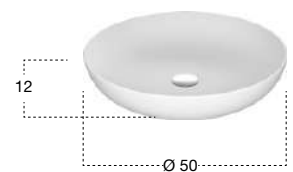

VERSO





lavabi / sinks



CATINO Ø 50 cm



CATINO43 Ø 43 cm

lavabi / sinks

CATINO43

CATINO

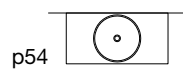
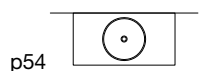
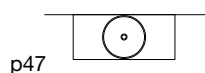

Verniciabile esternamente in tutti i colori del nostro campionario
Can be externally lacquered in all colors of our collection

H	Ø	art.
15	43	CATINO43
15	50	CATINO

Lavabo tondo sopra piano in Flumood completo di piletta con scarico libero e raccordo per sifone.

Round top mount Flumood sink complete with drain pipe fitting and open plug.

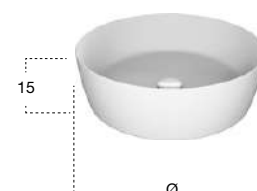

CATINO





lavabi / sinks

FLUMOOD

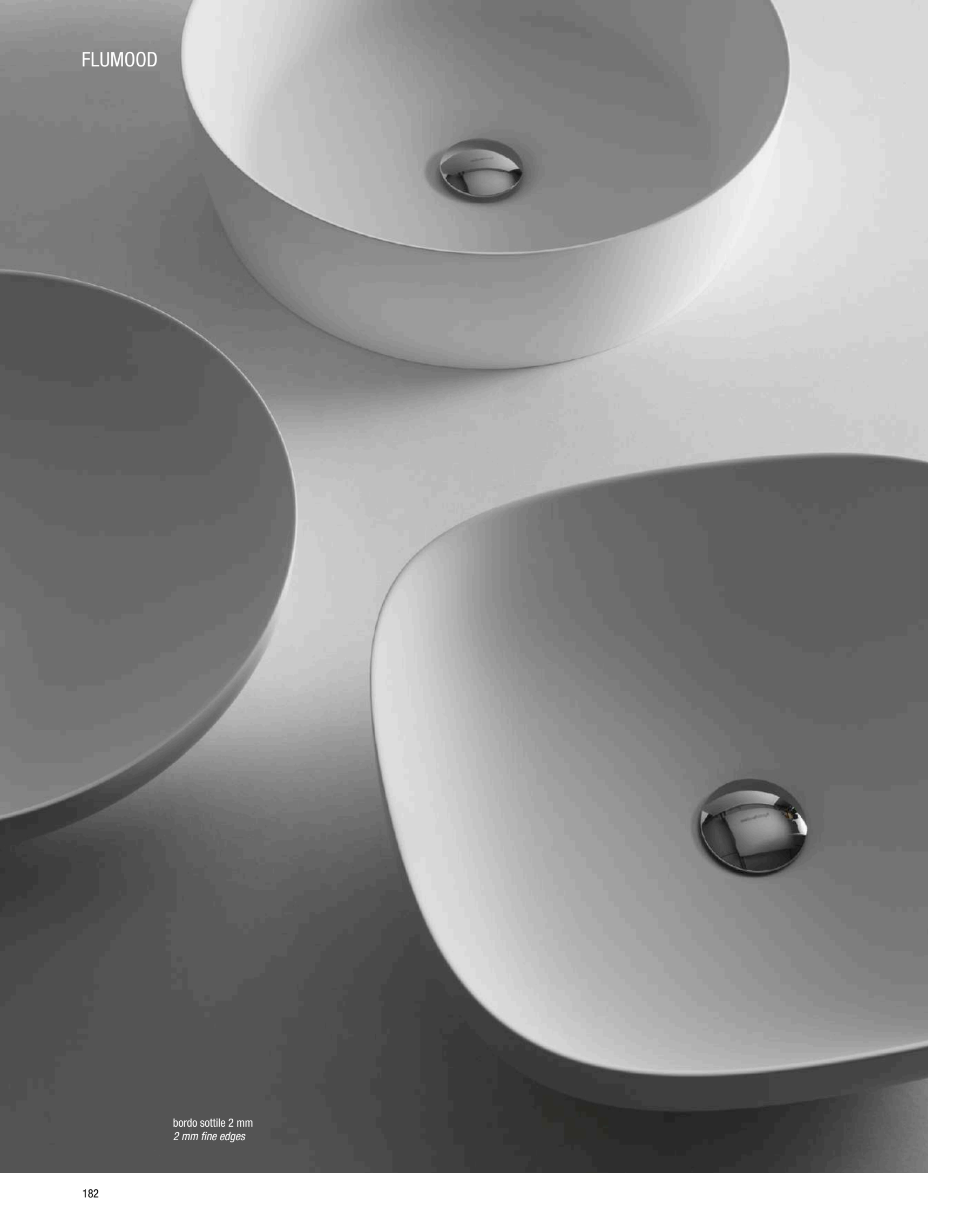

bordo sottile 2 mm
2 mm fine edges



lavabi / sinks

bordo arrotondato
rounded edges



lavabo SERV054 in CERAMILUX®
CERAMILUX® sink SERV054



lavabo SERVOMOOD54 in FLUMOOD®
FLUMOOD® sink SERVOMOOD54



lavabi / sinks

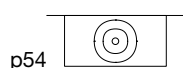
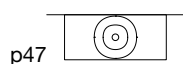
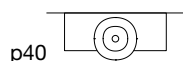

H	P	L	art.
15	45	45	SERVOM00D45

Lavabo tondo sopra piano in Flumood, completo di piletta con scarico libero e raccordo per sifone.

Round top mount Flumood sink, complete with drain pipe fitting and open plug.

H	P	L	art.
12,5	35	35	SERV035
15	45	45	SERV045

Lavabo tondo sopra piano in Ceramilux, completo di piletta con scarico libero e raccordo per sifone.

Round top mount Ceramilux sink, complete with drain pipe fitting and open plug.

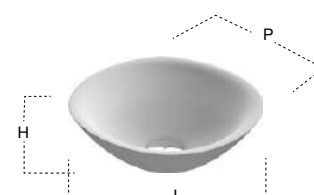

SERVO

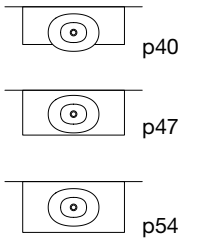

H	P	L	art.
15	40	54	SERVOM00D54

Lavabo ovale sopra piano in Flumood, completo di piletta con scarico libero e raccordo per sifone.

Oval top mount Flumood sink, complete with drain pipe fitting and open plug.

H	P	L	art.
15	40	54	SERV054

Lavabo ovale sopra piano in Ceramilux, completo di piletta con scarico libero e raccordo per sifone.

Oval top mount Ceramilux sink, complete with drain pipe fitting and open plug.

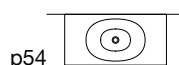
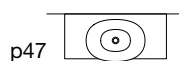
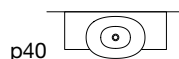

H	P	L	art.
15	45	63	SERVOMOOD63

Lavabo ovale sopraiano in Flumood completo di piletta con scarico libero e raccordo per sifone.

Oval top mount Flumood sink complete with drain pipe fitting and open plug.

H	P	L	art.
15	45	63	SERV063

Lavabo ovale sopraiano in Ceramilux completo di piletta con scarico libero e raccordo per sifone.

Oval top mount Ceramilux sink complete with drain pipe fitting and open plug.

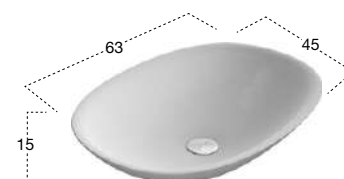

FLUMOOD





lavabi / sinks





lavabi / sinks

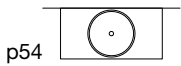
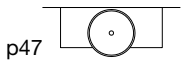
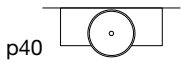

Verniciabile esternamente in tutti i colori del nostro campionario
Can be externally lacquered in all colors of our collection

H	Ø	art.
23,5	50	URNAMOOD

Lavabo tondo sopraiano in Flumood completo di piletta con scarico libero e raccordo per sifone.

Round top mount Flumood sink complete with drain pipe fitting and open plug.

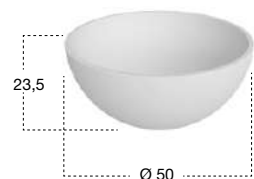

URNAMOOD





lavabi / sinks





lavabi / sinks

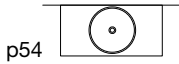
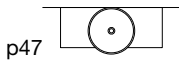
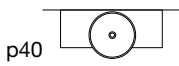

* Verniciabile esternamente in tutti i colori del nostro campionario
Can be externally lacquered in all colors of our collection

H	Ø	art.
20	50	TONDOMOOD *

Lavabo tondo sopra piano in Flumood completo di piletta con scarico libero e raccordo per sifone.

Round top mount Flumood sink complete with drain pipe fitting and open plug.

H	Ø	art.
20	50	SERVOTONDO

Lavabo tondo sopra piano in Ceramilux, completo di piletta con scarico libero e raccordo per sifone.

Round top mount Ceramilux sink complete with drain pipe fitting and open plug.

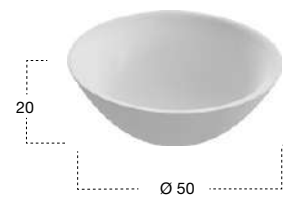





lavabi / sinks

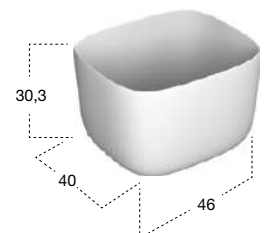
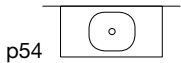
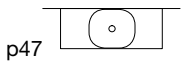
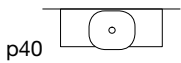

H	P	L	art.
30,3	40	46	POGGIO

Lavabo rettangolare sopraiano in Flumood completo di piletta con scarico libero e raccordo per sifone.

Rectangular top mount Flumood sink complete with drain pipe fitting and open plug.

BOLO design Mario Ferrarini

Cos'è un lavabo se non un vaso contenente acqua a cui abbiamo aggiunto uno scarico? La tipica sezione a "collo di bottiglia" è il tratto distintivo della collezione Bolo e ne identifica tutti gli elementi. Le linee sono morbide e arrotondate, le geometrie essenziali, l'immagine complessiva discreta ma allo stesso tempo elegante: i lavabi da appoggio della collezione Bolo realizzati in Ceramilux e Flumood sono presenze amiche e confortanti che ci accompagnano nell'ambiente bagno trasmettendoci una sensazione di leggerezza e di sofisticata pulizia estetica. Bolo, che nella forma gergale delle ceramiche artistiche indica il vaso, riprende volutamente l'origine dell'impasto utilizzato nella realizzazione del ciotolame, per evidenziare un immaginario percorso evolutivo dalle sue origini alle nuove tecnologie della produzione in serie. Quattro lavabi caratterizzati da spessori minimi declinati nelle forme geometriche elementari: dal cerchio al quadrato, dal rettangolo all'ovale. I diversi modelli per installazione sopra piano sono accomunati dalla sezione eccezionalmente esile e dal copri piletta integrato con il bacino. La base si restringe rispetto al volume del bacino dei lavabi, così che questi risultino quasi sospesi, come se galleggiassero nell'aria invece di essere appoggiati su un piano. Si ha la sensazione che questi elementi si possano muovere da un momento all'altro su un cuscinetto d'aria e lievitare... eterei come nuvole ma in realtà solidi e concreti come pietre.

What is a sink if not a vessel containing water to which we added a drain? The typical section to "bottleneck" is the hallmark of the Bolo collection and identifies all the elements. The lines are soft and rounded, basic geometry, a discrete overall image at the same time elegant: the washbasins of the Bolo collection made of Ceramilux and Flumood are send us a feeling of lightness and sophisticated clean lines.

Four sinks characterized by minimal thicknesses in elementary geometric shapes: circle, square rectangle and oval. The different models for top mounting are united by the exceptionally thin section and drain integrated in the basin. The base is narrowed compared to the volume of the basin so they seem almost suspended as if they were floating on air. One has the feeling that these elements can move at any moment on a cushion of air and rise ... ethereal as clouds but solid and concrete as stones.





lavabi / sinks



BOL054
54 x 40 x 12,5 cm



BOL045
Ø 45 cm x 12,5 cm



BOL063
63 x 40 x 12,5 cm



BOL040
40 x 40 x 12,5 cm

lavabi / sinks

BOLO





lavabi / sinks

BOLO

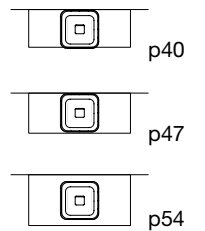

H	P	L	art.
12,5	40	40	BOLOM00D40

Lavabo quadrato sopra piano in Flumood completo di piletta con scarico libero e raccordo per sifone.

Square top mount Flumood sink complete with drain pipe fitting and open plug.

H	P	L	art.
12,5	40	40	BOLO40

Lavabo quadrato sopra piano in Ceramilux completo di piletta con scarico libero e raccordo per sifone.

Square top mount Ceramilux sink complete with drain pipe fitting and open plug.

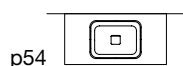
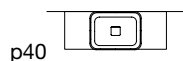

H	P	L	art.
12,5	40	54	BOLOMOOD54

Lavabo rettangolare sopraiano in Flumood completo di piletta con scarico libero e raccordo per sifone.

Rectangular top mount Flumood sink complete with drain pipe fitting and open plug.

H	P	L	art.
12,5	40	54	BOLO54

Lavabo rettangolare sopraiano in Ceramilux completo di piletta con scarico libero e raccordo per sifone.

Rectangular top mount Ceramilux sink complete with drain pipe fitting and open plug.

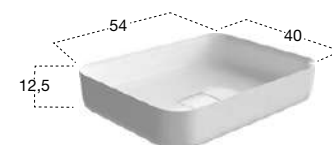

BOLO

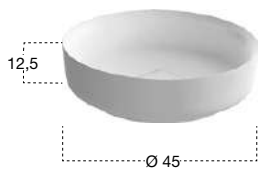
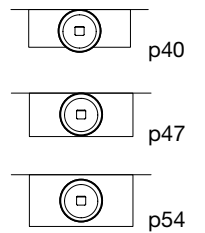

H	Ø	art.
12,5	45	BOLOM00D45

Lavabo tondo sopraiano in Flumood completo di piletta con scarico libero e raccordo per sifone.

Round top mount Flumood sink complete with drain pipe fitting and open plug.

H	Ø	art.
12,5	45	BOLO45

Lavabo tondo sopraiano in Ceramilux completo di piletta con scarico libero e raccordo per sifone.

Round top mount Ceramilux sink complete with drain pipe fitting and open plug.



lavabi / sinks

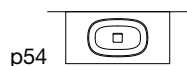
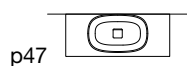
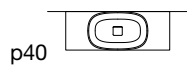

H	P	L	art.
12,5	40	63	BOLOM00D63

Lavabo ovale sopra piano in Flumood completo di piletta con scarico libero e raccordo per sifone.

Oval top mount Flumood sink complete with drain pipe fitting and open plug.

H	P	L	art.
12,5	40	63	BOL063

Lavabo ovale sopra piano in Ceramilux completo di piletta con scarico libero e raccordo per sifone.

Oval top mount Ceramilux sink complete with drain pipe fitting and open plug.





FOGLIO design Mario Ferrarini

Un foglio, uno strato sottile di materia plasmata dall'acqua e piegata dalla gravità si adagia dolcemente su una superficie d'appoggio restando quasi sospesa a librarsi nell'aria.

Leggero come un foglio di carta, sospeso come una piuma che sembra solo lambire leggermente la superficie, addolcito dalla forza dell'acqua che ne ha modificato la planarità e trasformato la perfetta ortogonalità Foglio è un lavabo da semi incasso che presenta un bacino ampio e aperto e una base dalle dimensioni ridotte che quasi scompare alla vista amplificando ulteriormente la sensazione di sospensione rispetto al piano d'appoggio. Il volume non presenta soluzione di continuità, la depressione creata al centro del lavabo scava di fatto la materia e origina un bacino "naturale" nel quale raccogliere l'acqua.

A sheet, a thin layer of material formed from water and bent by gravity on a bearing surface remaining almost suspended to hover in the air.

As light as a sheet of paper, suspended like a feather that seems only slightly lapping the surface, softened by the force of the water it has changed the flatness and transformed perfectly square Foglio is a semi recessed basin with a large and open basin and a base of reduced dimensions that almost disappears from view further amplifying the feeling of suspension with respect to the top.



lavabi / sinks

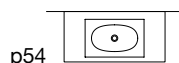
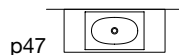

H	P	L	art.
14	40,4	63	FOGLIOM00D63

Lavabo rettangolare sopra piano ad incasso in Flumood, completo di piletta con scarico libero e raccordo per sifone.

Rectangular encased Flumood sink, complete with drain pipe fitting and open plug.

H	P	L	art.
14	40,4	63	FOGLIO63

Lavabo rettangolare sopra piano ad incasso in Ceramilux, completo di piletta con scarico libero e raccordo per sifone.

Rectangular encased Ceramilux sink, complete with drain pipe fitting and open plug.

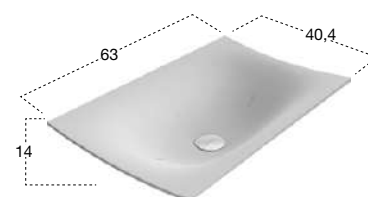





lavabi / sinks

RETTOMOOD50
SERVORETTO50

RETTOMOOD63
SERVORETTO63

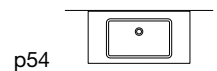
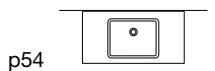
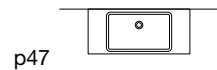
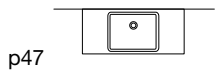
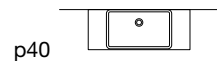
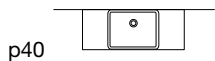

H	P	L	art.
13	38	50	RETTOMOOD50
	38	63	RETTOMOOD63

Lavabo rettangolare sopra piano in Flumood completo di piletta con scarico libero e raccordo per sifone.

Rectangular top mount Flumood sink complete with drain pipe fitting and open plug.

H	P	L	art.
13	38	50	SERVORETTO50
	38	63	SERVORETTO63

Lavabo rettangolare sopra piano in Ceramilux completo di piletta con scarico libero e raccordo per sifone.

Rectangular top mount Ceramilux sink complete with drain pipe fitting and open plug.

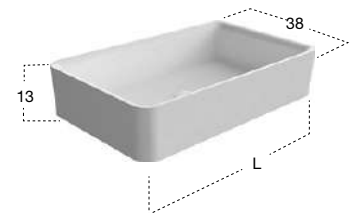





lavabi / sinks

RETTOMOOD50
SERVORETTO50

RETTOMOOD63
SERVORETTO63

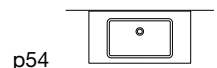
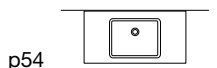
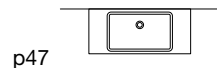
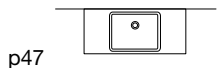

H	P	L	art.
13	38	50	RETTOMOOD50
	38	63	RETTOMOOD63

Lavabo rettangolare sottopiano in Flumood completo di piletta con scarico libero e raccordo per sifone.

Rectangular undermount Flumood sink complete with drain pipe fitting and open plug.

H	P	L	art.
13	38	50	SERVORETTO50
	38	63	SERVORETTO63

Lavabo rettangolare sottopiano in Ceramilux completo di piletta con scarico libero e raccordo per sifone.

Rectangular undermount Ceramilux sink complete with drain pipe fitting and open plug.

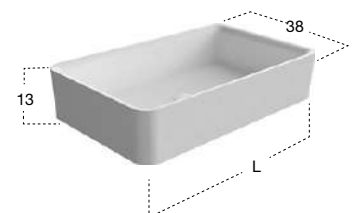

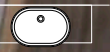

p40 

p47 

p54 



lavabi / sinks

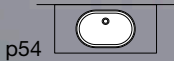

H	P	L	art.
12	42	63	PIPER1

Lavabo ovale sopra piano o sottopiano in Ceramilux completo di piletta con scarico libero e raccordo per sifone.

Oval top or undermount Ceramilux sink, complete with drain pipe fitting and open plug.

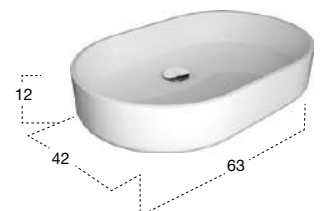





lavabi / sinks

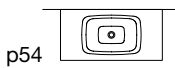
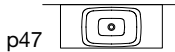

H	P	L	art.
15	42	63	BULBO

Lavabo rettangolare sopra piano a incasso in Ceramilux completo di piletta con scarico libero e raccordo per sifone.

Rectangular encased Ceramilux sink, complete with drain pipe fitting and open plug.





lavabi / sinks

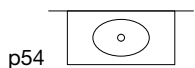
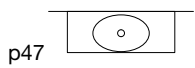
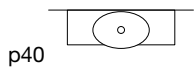

H	P	L	art.
15	46	68	SOLIDEA

Lavabo ovale sopra piano in Cristalplant completo di piletta con scarico libero e raccordo per sifone.

Oval top mount Cristalplant sink complete with drain pipe fitting and open plug.



BLOKKO design Carlo Colombo

Puro, nella sua geometria rigorosa, contaminato, nella dicotomia tra spigoli esterni netti e precisi e angoli interni arrotondati, per un contrasto formale che genera nuovi valori.

Si presenta proprio come un blocco compatto ed è così che infatti si chiama. Blokko, realizzato in Cristalplant o Marmo di Carrara è un elemento che fa del perfetto equilibrio proporzionale la propria forza espressiva. Ideato per assumere la posizione di centro stanza si esprime al meglio con il mobile integrato delle stesse dimensioni con il quale finisce per costituire un blocco monolitico rigoroso e minimale.

Pure in its rigorous geometry, contaminated, in the dichotomy between net external edges and precise and rounded corners, for a formal contrast that creates new values.

It looks just like a compact block and that is also its name. Blokko, made of Carrara marble or Cristalplant. Designed to take on the position of the center of the room and expresses itself better with a cabinet of the same size with which end up constituting a rigorous and minimalist monolithic block.





lavabi / sinks

BLOKK02

BLOKK010

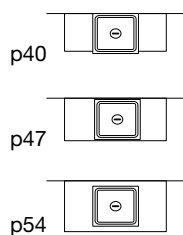

BLOKK02

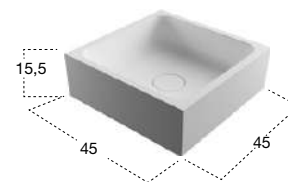

BLOKK010

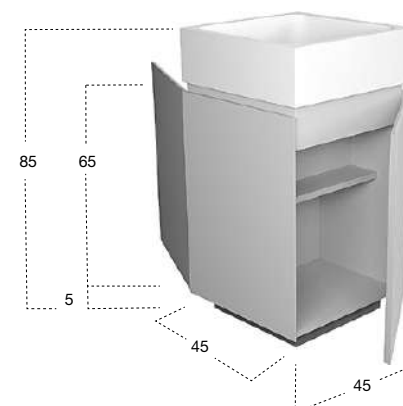

H	P	L	art.
15,5	45	45	BLOKK02

Lavabo quadro sopra piano in Cristalplant, completo di piletta con scarico libero e raccordo per sifone.

Square Cristalplant top mount sink complete with drain pipe fitting and open plug.

H	P	L	art.
85	45	45	BLOKK010

Centro stanza con 2 ante, 1 posteriore e 1 anteriore dx o sx e 1 ripiano interno in legno, completo di zoccolo nero goffrato, e lavabo in Cristalplant.

Freestanding cabinet with 2 doors, front and back right or left and one internal wooden shelf, complete with plinth lacquered embossed black and Cristalplant sink.

GRAFFIO design Mario Ferrarini

La contaminazione fra forme geometriche semplici, l'estetica del bordo sottile che delimita e contiene, la forza del graffio, che incide la materia e le attribuisce nuova funzione.

Nuovi equilibri proporzionali e formali nati dall'intersezione di quadrati, cerchi e rettangoli sapientemente dimensionati: Graffio è una collezione di 5 diversi lavabi sopra-piano o a parete realizzati in Ceramilux. L'estrema sottigliezza del bordo rimanda all'immagine di una linea tracciata per definire un perimetro che racchiude al suo interno tutte le funzioni del lavabo: il bacino, il piano d'appoggio sul quale installare il rubinetto e un piano supplementare di servizio. Un dettaglio reso possibile grazie all'evoluzione tecnologica nella lavorazione del materiale, un elemento che oltre a connotare l'estetica del progetto consente di aumentare la capacità del bacino mantenendo invariato l'ingombro complessivo.

Contamination between simple geometric forms, the aesthetics of the thin borders that defines and contain the strength of Graffio, which affects the material and gives it new function.

New proportional and formal balance born from the intersection of squares, circles, and rectangles: Graffio is a collection of five different washbasins, top or wall mount, made of Ceramilux. The extreme thinness of the borders define a perimeter that encloses all the functions of the basin: the basin, the back surface where to install the faucet as well an additional surface. One detail made possible thanks to the technological evolution in the processing of the material, an element which not only characterizes the aesthetics of the project but allows you to increase the capacity of the basin without changing the overall footprint.



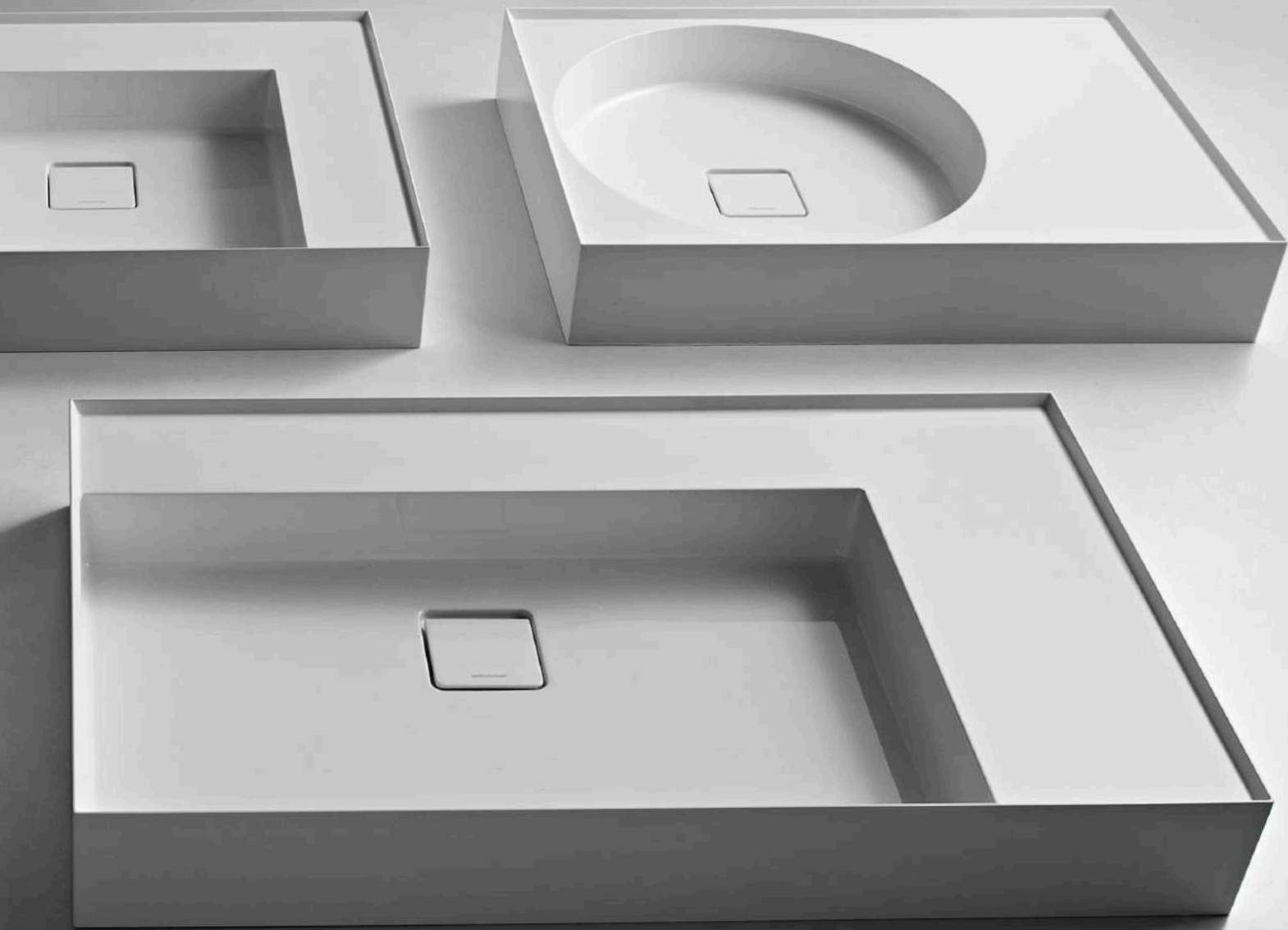

lavabi / sinks

GRAFFIO

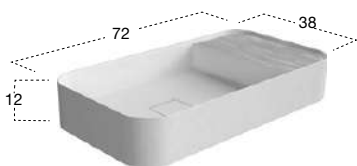
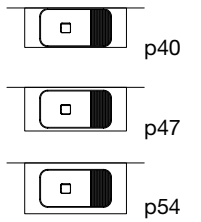

H	P	L	art.
12	38	72	GRAFFIO38

Lavabo rettangolare sopra piano in Ceramilux con ripiano, completo di piletta con scarico libero e raccordo per sifone.

Rectangular top mount Ceramilux sink with shelf, complete with drain pipe fitting and open plug.



lavabi / sinks

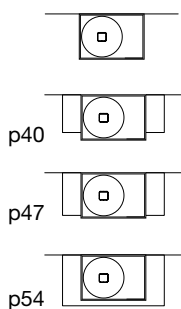

H	P	L	art.
12	50	72	GRAFFIO72

Lavabo rettangolare sopra piano o da parete in Ceramilux con ripiano, completo di piletta con scarico libero e raccordo per sifone.

Rectangular top mount or wall mount Ceramilux sink with shelf, complete with drain pipe fitting and open plug.





lavabi / sinks

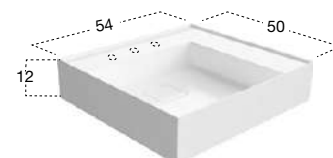
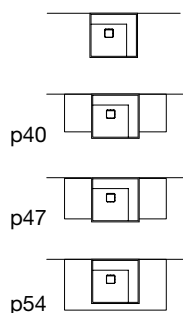

H	P	L	art.
12	50	54	GRAFFIO54

Lavabo rettangolare sopra piano o da parete in Ceramilux con ripiano, completo di piletta con scarico libero e raccordo per sifone.

Rectangular top mount or wall mount Ceramilux sink with shelf, complete with drain pipe fitting and open plug.





lavabi / sinks

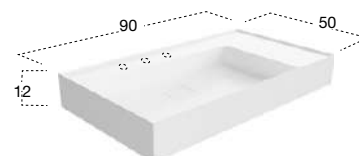
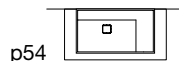
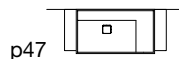
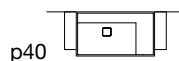

H	P	L	art.
12	50	90	GRAFFIO90

Lavabo rettangolare sopra piano o da parete in Ceramilux con ripiano, completo di piletta con scarico libero e raccordo per sifone.

Rectangular top mount or wall mount Ceramilux sink with shelf, complete with drain pipe fitting and open plug.





lavabi / sinks

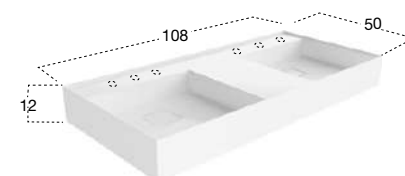
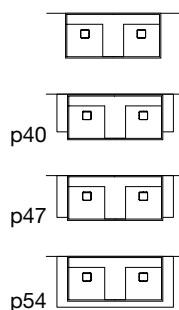

H	P	L	art.
12	50	108	GRAFFIO108

Lavabo rettangolare sopra piano o da parete in Ceramilux con ripiano, completo di piletta con scarico libero e raccordo per sifone.

Rectangular top mount or wall mount Ceramilux sink with shelf, complete with drain pipe fitting and open plug.



GRFKI154 / GRFKA154

H	P	L	art.
12	50	54	GRAFFIO54

Lavabo rettangolare sopra piano o da parete in Ceramilux con ripiano, completo di piletta con scarico libero e raccordo per sifone.

Rectangular top mount or wall mount Ceramilux sink with shelf, complete with drain pipe fitting and open plug.

H	P	L	art.
37,5	50	54	GRFKI154

H	P	L	art.
50	50	54	GRFKA154

Porta lavabo con 1 cassetto Art. SLIM, abbinabile solo con lavabo Art. GRAFFIO54.

Sink unit with 1 drawer Art. SLIM to be combined with Art. GRAFFIO54.

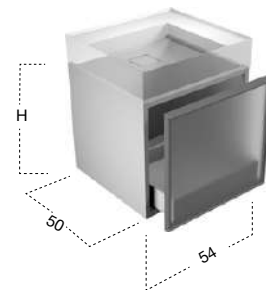

GRFKI190 / GRFKA190

H	P	L	art.
12	50	90	GRAFFIO90

Lavabo rettangolare sopra piano o da parete in Ceramilux con ripiano, completo di piletta con scarico libero e raccordo per sifone.

Rectangular top mount or wall mount Ceramilux sink with shelf, complete with drain pipe fitting and open plug.

H	P	L	art.
37,5	50	90	GRFKI190

H	P	L	art.
50	50	90	GRFKA190

Porta lavabo con 1 cassetto Art. SLIM, abbinabile solo con lavabo Art. GRAFFIO90.

Sink unit with 1 drawer Art. SLIM to be combined with Art. GRAFFIO90.

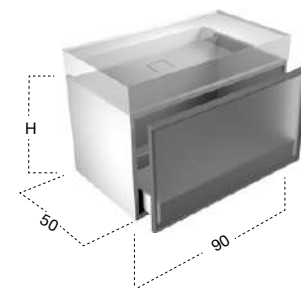

lavabi / sinks

GRFKI1108 / GRFKA1108

H	P	L	art.
12	50	108	GRAFFIO108

Lavabo rettangolare sopra piano o da parete in Ceramilux con ripiano, completo di piletta con scarico libero e raccordo per sifone.

Rectangular top mount or wall mount Ceramilux sink with shelf, complete with drain pipe fitting and open plug.

H	P	L	art.
37,5	50	108	GRFKI1108

H	P	L	art.
50	50	108	GRFKA1108

Porta lavabo con 1 cassetto Art. SLIM, abbinabile solo con lavabo Art. GRAFFIO108.

Sink unit with 1 drawer Art. SLIM to be combined with Art. GRAFFIO108.

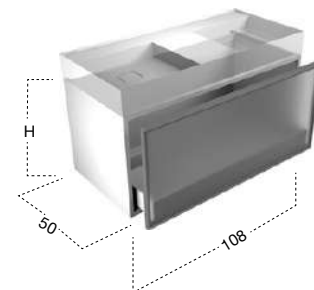



GRAFFIO54

H	P	L	art.
12	50	54	GRAFFIO54

Lavabo rettangolare sopra piano o da parete in Ceramilux con ripiano, completo di piletta con scarico libero e raccordo per sifone.

Rectangular top mount or wall mount Ceramilux sink with shelf, complete with drain pipe fitting and open plug.

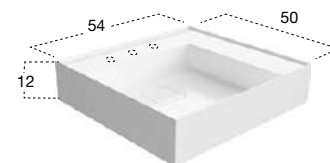

GRAFFIO12554

H	P	L	art.
37,5	50	54	GRAFFIO12554

Portlavabo con 1 cassetto Art. SLIM, abbinabile solo con lavabo Art. GRAFFIO54.

Sink unit with 1 drawer Art. SLIM, to be combined with Art. GRAFFIO54.

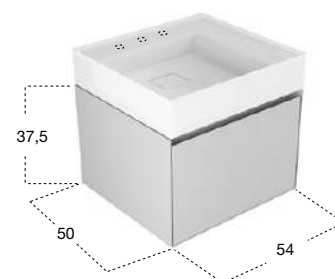

GRAFFIO13554

H	P	L	art.
50	50	54	GRAFFIO13554

Portlavabo con 1 cassetto Art. SLIM, abbinabile solo con lavabo Art. GRAFFIO54.

Sink unit with 1 drawer Art. SLIM, to be combined with Art. GRAFFIO54.

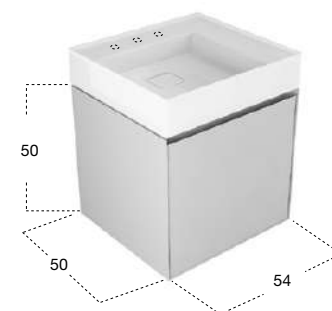

GRAFFIO33554

H	P	L	art.
50	50	54	GRAFFIO33554

Portlavabo con 2 cassetti Art. SLIM di cui uno sagomato internamente per sifone, abbinabile solo con lavabo Art. GRAFFIO54.

Sink unit with 2 drawers Art. SLIM, one of which internally shaped for siphon, to be combined with Art. GRAFFIO54.

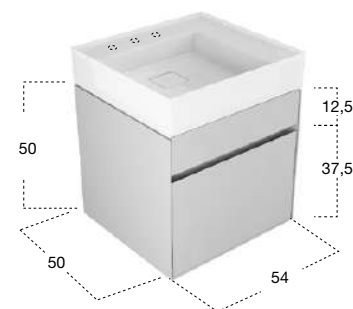



GRAFFIO90

H	P	L	art.
12	50	90	GRAFFIO90

Lavabo rettangolare sopra piano o da parete in Ceramilux con ripiano, completo di piletta con scarico libero e raccordo per sifone.

Rectangular top mount or wall mount Ceramilux sink with shelf, complete with drain pipe fitting and open plug.

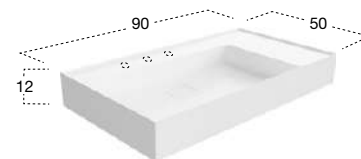

GRAFFIO12590

H	P	L	art.
37,5	50	90	GRAFFIO12590

PortLavabo con 1 cassetto Art. SLIM, abbinabile solo con lavabo Art. GRAFFIO90.

Sink unit with 1 drawer Art. SLIM, to be combined with Art. GRAFFIO90.

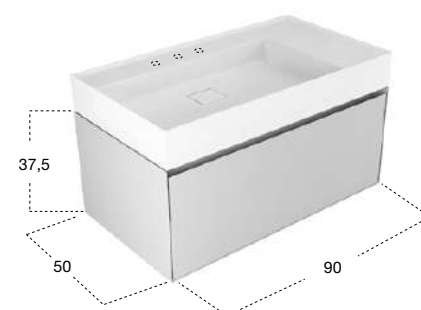

GRAFFIO13590

H	P	L	art.
50	50	90	GRAFFIO13590

PortLavabo con 1 cassetto Art. SLIM, abbinabile solo con lavabo Art. GRAFFIO90.

Sink unit with 1 drawer Art. SLIM, to be combined with Art. GRAFFIO90.

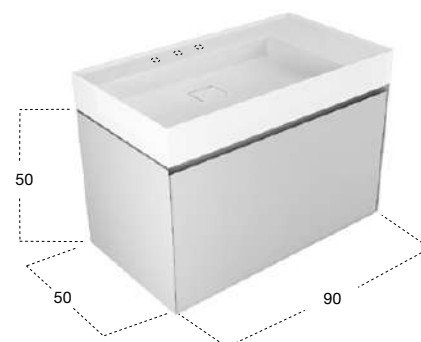

GRAFFIO33590

H	P	L	art.
50	50	90	GRAFFIO33590

PortLavabo con 2 cassetti Art. SLIM di cui uno sagomato internamente per sifone, abbinabile solo con lavabo Art. GRAFFIO90.

Sink unit with 2 drawers Art. SLIM, one of which internally shaped for siphon, to be combined with Art. GRAFFIO90.

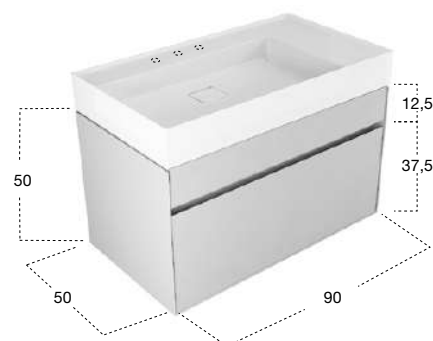



GRAFFIO108

H	P	L	art.
12	50	108	GRAFFIO108

Lavabo rettangolare sopra piano o da parete in Ceramilux con ripiano, completo di piletta con scarico libero e raccordo per sifone.

Rectangular top mount or wall mount Ceramilux sink with shelf, complete with drain pipe fitting and open plug.

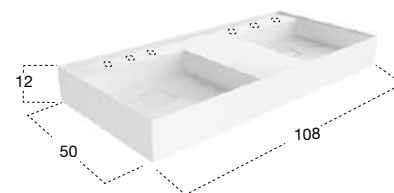

GRAFFIO125108

H	P	L	art.
37,5	50	108	GRAFFIO125108

Porta lavabo con 1 cassetto Art. SLIM, abbinabile solo con lavabo Art. GRAFFIO108.

Sink unit with 1 drawer Art. SLIM, to be combined with Art. GRAFFIO108.

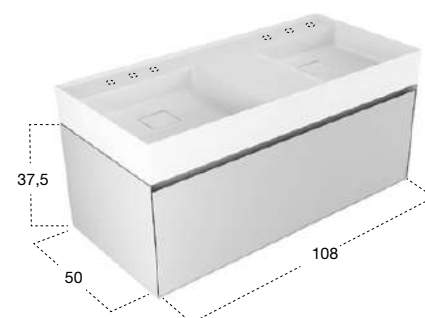

GRAFFIO135108

H	P	L	art.
50	50	108	GRAFFIO135108

Porta lavabo con 1 cassetto Art. SLIM, abbinabile solo con lavabo Art. GRAFFIO108.

Sink unit with 1 drawer Art. SLIM, to be combined with Art. GRAFFIO108.

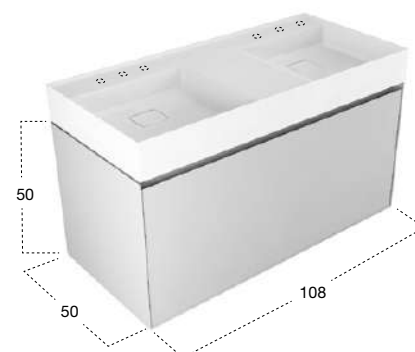

GRAFFIO335108

H	P	L	art.
50	50	108	GRAFFIO335108

Porta lavabo con 2 cassetti Art. SLIM di cui uno sagomato internamente per sifone, abbinabile solo con lavabo Art. GRAFFIO108.

Sink unit with 2 drawers Art. SLIM, one of which internally shaped for siphon, to be combined with Art. GRAFFIO108.

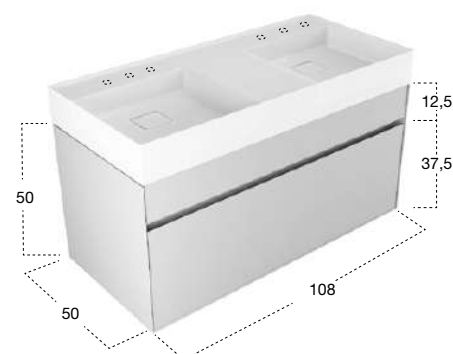

GESTO design Nevio Tellatin

Un tratto semplice, una serie di varianti dimensionali studiate in rapporto alla modularità dei sistemi, una forma conosciuta riattualizzata, rivista, ottimizzata.

È il gesto del lavarsi le mani a dare senso, e anche nome, alla composizione. È la semplicità dell'azione a generare gli elementi di questa collezione di lavabi in Ceramilux. È l'esperienza produttiva di Antoni Lupi nella lavorazione della materia ad aver favorito la rivisitazione della classica tipologia del lavabo a "canale", riproposto sfruttando le peculiarità del nuovo sistema costruttivo, rendendolo un elemento monolitico che può essere utilizzato sia autonomamente installandolo sospeso, che in abbinamento ai mobili. Il bordo perimetrale è stato ridotto al minimo per dare spazio al bacino e il raccordo armonioso degli angoli interni rende facile la pulizia anche alle estremità. Un oggetto semplice, di uso quotidiano, un segno preciso e rigoroso che rassicura. Gesto è portatore di una normalità che diventa valore all'interno dell'abitare contemporaneo.

A simplified line, a series of models in different sizes studied in relation to the modularity of the systems, a know shape, revisited, revised, optimized.

It is the gesture of washing your hands to make sense and name to the collection. It is the simplicity of the action to generate the elements of this collection of sinks in Ceramilux. It is the productive experience of Antoni Lupi in the workmanship of the material to have favored the revival of the classical type of sink to "channel" proposed again by exploiting the features of the new construction making it a monolithic element that can be used alone or on cabinets. The border has been reduced significantly to give room for the basin and allow for easy cleaning. A simple object, for daily use a precise and rigorous sign that assures. Gesto is the bearer of a normality that becomes value in contemporary living.





lavabi / sinks

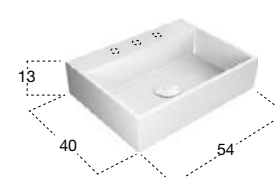
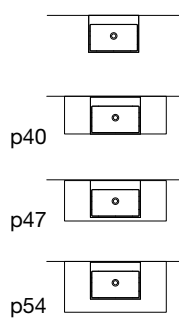

H	P	L	art.
13	40	54	GEST054

Lavabo rettangolare sopraiano o da parete in Ceramilux lucido o opaco, completo di piletta con scarico libero e raccordo per sifone.

Rectangular top mount or wall mount glossy or matt Ceramilux sink, complete with drain pipe fitting and open plug.



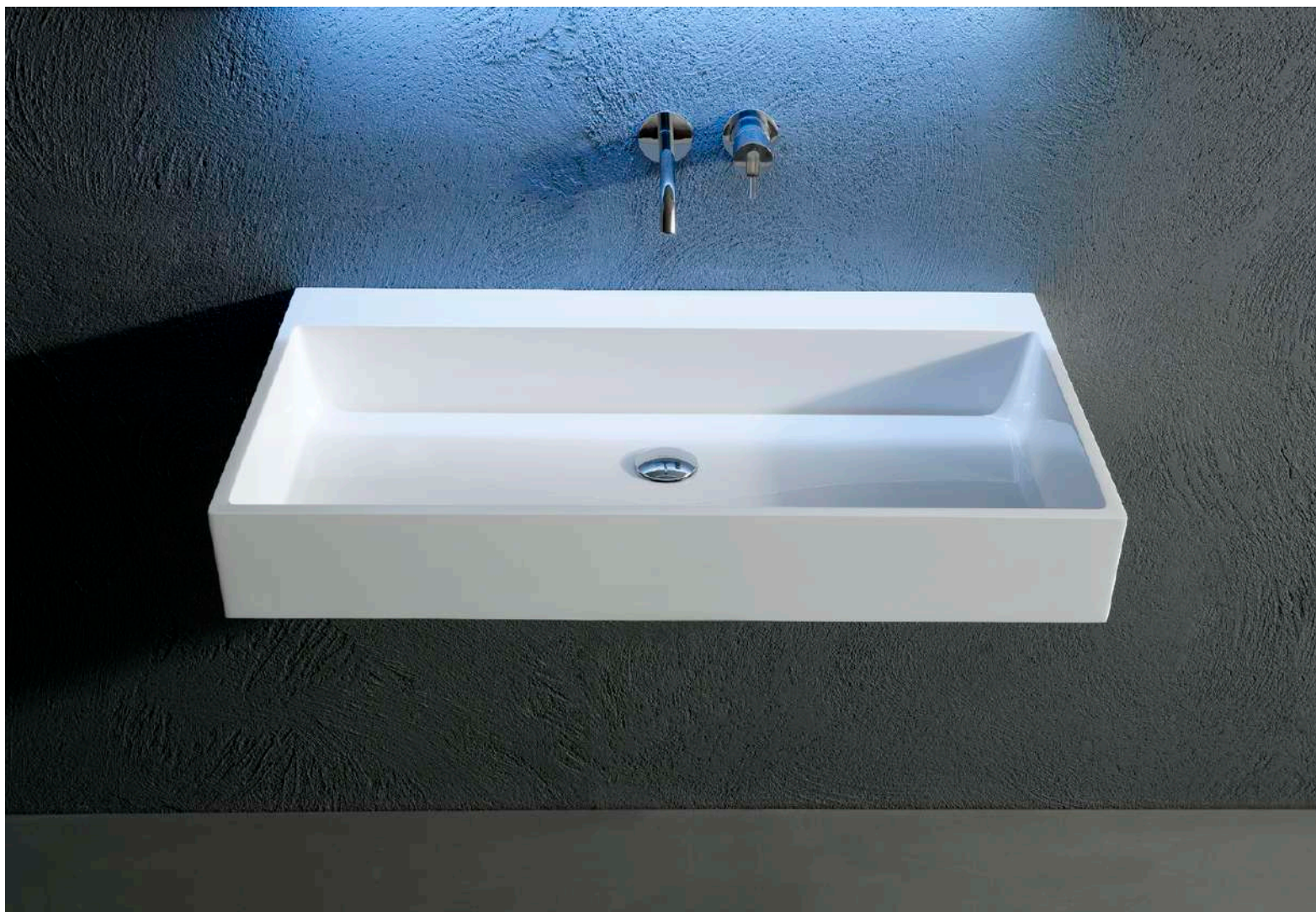

lavabi / sinks

GEST063

GEST090

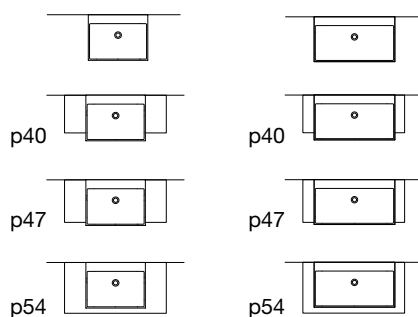

H	P	L	art.
13	50	63	GEST063
	50	90	GEST090

Lavabo rettangolare sopra piano o da parete in Ceramilux lucido o opaco, completo di piletta con scarico libero e raccordo per sifone.

Rectangular top mount or wall mount glossy or matt Ceramilux sink, complete with drain pipe fitting and open plug.







lavabi / sinks

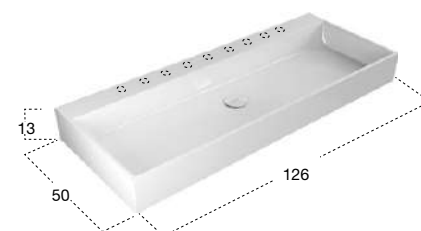
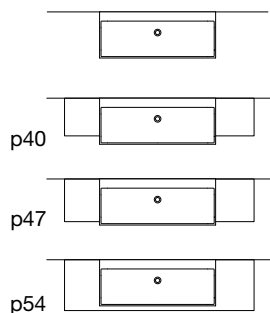

H	P	L	art.
13	50	126	GEST0126

Lavabo rettangolare sopra piano o da parete in Ceramilux lucido o opaco, completo di piletta con scarico libero e raccordo per sifone.

Rectangular top mount or wall mount glossy or matt Ceramilux sink, complete with drain pipe fitting and open plug.



GSTKI154

H	P	L	art.
13	40	54	GEST054

Lavabo rettangolare sopra piano o da parete in Ceramilux lucido o opaco, completo di piletta con scarico libero e raccordo per sifone.

Rectangular top mount or wall mount glossy or matt Ceramilux sink, complete with drain pipe fitting and open plug.

H	P	L	art.
37,5	40	54	GSTKI154

Porta lavabo con 1 cassetto Art. SLIM, abbinabile solo con lavabo Art. GEST054.

Sink unit with 1 drawer Art. SLIM to be combined with Art. GEST054.

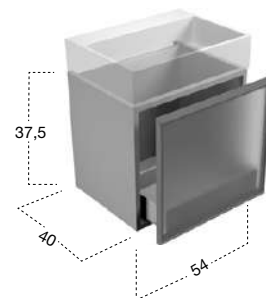

H	P	L	art.
13	50	90	GEST090

Lavabo rettangolare sopra piano o da parete in Ceramilux lucido o opaco completo di piletta con scarico libero e raccordo per sifone.

Rectangular top mount or wall mount glossy or matt Ceramilux sink complete with drain pipe fitting and open plug.

H	P	L	art.
37,5	50	63	GSTKI163

H	P	L	art.
50	50	63	GSTKA163

Porta lavabo con 1 cassetto Art. SLIM, abbinabile solo con lavabo Art. GEST063.

Sink unit with 1 drawer Art. SLIM to be combined with Art. GEST063.

GSTKI163 / GSTKA163

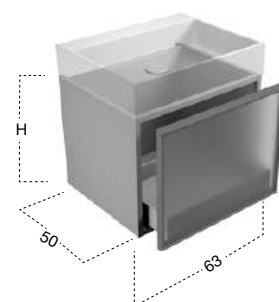

H	P	L	art.
13	50	90	GEST090

Lavabo rettangolare sopra piano o da parete in Ceramilux lucido o opaco completo di piletta con scarico libero e raccordo per sifone.

Rectangular top mount or wall mount glossy or matt Ceramilux sink complete with drain pipe fitting and open plug.

H	P	L	art.
37,5	50	90	GSTKI190

H	P	L	art.
50	50	90	GSTKA190

Porta lavabo con 1 cassetto Art. SLIM, abbinabile solo con lavabo Art. GEST090.

Sink unit with 1 drawer Art. SLIM to be combined with Art. GEST090.

GSTKI190 / GSTKA190

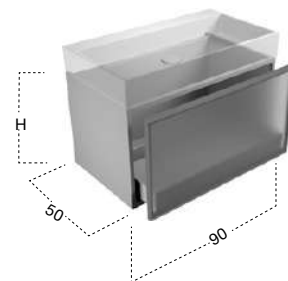

H	P	L	art.
13	50	126	GEST0126

Lavabo rettangolare sopra piano o da parete in Ceramilux lucido o opaco completo di piletta con scarico libero e raccordo per sifone.

Rectangular top mount or wall mount glossy or matt Ceramilux sink complete with drain pipe fitting and open plug.

H	P	L	art.
37,5	50	126	GSTKI1126

H	P	L	art.
50	50	126	GSTKA1126

Porta lavabo con 1 cassetto Art. slim, abbinabile solo con lavabo Art. GEST0126.

Sink unit with 1 drawer Art. SLIM to be combined with Art. GEST0126.

GSTKI1126 / GSTKA1126

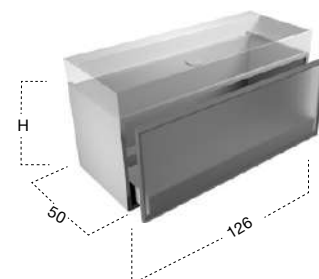



antonio lupi



lavabi / sinks

art. ELETTRA / ELETTRACH (per Svizzera / for Switzerland)

N° 2 prese di corrente opzionali per cassetti.

N° 2 optional sockets for drawers.

H	P	L	art.
13	40	54	GEST054

Lavabo rettangolare sopra piano o da parete in Ceramilux lucido o opaco, completo di piletta con scarico libero e raccordo per sifone.

Rectangular top mount or wall mount glossy or matt Ceramilux sink, complete with drain pipe fitting and open plug.

H	P	L	art.
37,5	40	54	GEST012454

Portalavabo con 1 cassetto Art. SLIM, abbinabile solo con lavabo Art. GEST054.

Sink unit with 1 drawer Art. SLIM to be combined with Art. GEST054 sink.

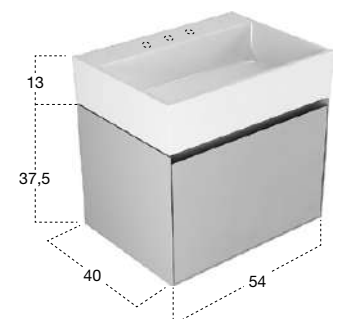



GEST063 + GEST012563 / GEST013563

H	P	L	art.
13	50	63	GEST063

Lavabo rettangolare sopra piano o da parete in Ceramilux lucido o opaco completo di piletta con scarico libero e raccordo per sifone.

Rectangular top mount or wall mount glossy or matt Ceramilux sink complete with drain pipe fitting and open plug.

H	P	L	art.
37,5	50	63	GEST012563
50	50	63	GEST013563

Porta lavabo con 1 cassetto Art. SLIM, abbinabile solo con lavabo Art. GEST063.

Sink unit with a Art. SLIM drawer to be combined with sink Art. GEST063.

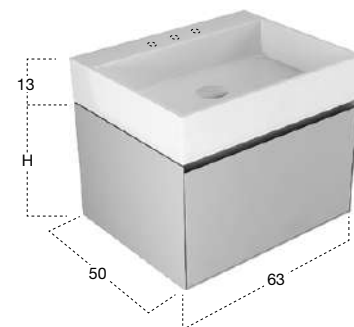

GEST090 + GEST012590 / GEST013590

H	P	L	art.
13	50	90	GEST090

Lavabo rettangolare sopra piano o da parete in Ceramilux lucido o opaco completo di piletta con scarico libero e raccordo per sifone.

Rectangular top mount or wall mount glossy or matt Ceramilux sink complete with drain pipe fitting and open plug.

H	P	L	art.
37,5	50	90	GEST012590
50	50	90	GEST013590

Porta lavabo con 1 cassetto Art. SLIM, abbinabile solo con lavabo Art. GEST090.

Sink unit with a Art. SLIM drawer to be combined with sink Art. GEST090.

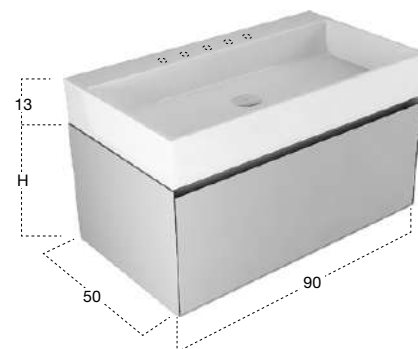

lavabi / sinks

GEST0126 + GEST0125126 / GEST0135126

H	P	L	art.
13	50	126	GEST0126

Lavabo rettangolare sopra piano o da parete in Ceramilux lucido o opaco completo di piletta con scarico libero e raccordo per sifone.

Rectangular top mount or wall mount glossy or matt Ceramilux sink complete with drain pipe fitting and open plug.

H	P	L	art.
37,5	50	126	GEST0125126
50	50	126	GEST0135126

Porta lavabo con 1 cassetto Art. SLIM, abbinabile solo con lavabo Art. GEST0126.

Sink unit with a Art. SLIM drawer to be combined with sink Art. GEST0126





GEST063 + GEST033563

H	P	L	art.
13	50	63	GEST063

Lavabo rettangolare sopra piano o da parete in Ceramilux lucido o opaco completo di piletta con scarico libero e raccordo per sifone.

Rectangular top mount or wall mount glossy or matt Ceramilux sink complete with drain pipe fitting and open plug.

H	P	L	art.
50	50	63	GEST033563

Porta lavabo con 2 cassetti Art. SLIM di cui 1 sagomato internamente per sifone, abbinabile solo con lavabo Art. GEST063.

Sink unit with 2 drawers Art. SLIM, one of which internally shaped for siphon, to be combined with sink Art. GEST063.

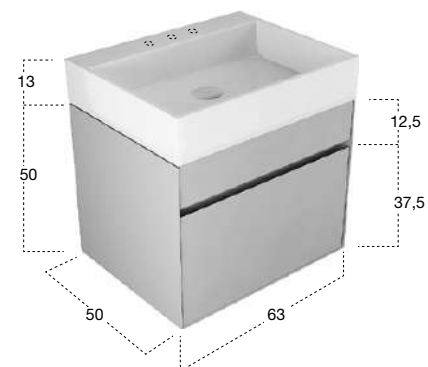

GEST090 + GEST033590

H	P	L	art.
13	50	90	GEST090

Lavabo rettangolare sopra piano o da parete in Ceramilux lucido o opaco completo di piletta con scarico libero e raccordo per sifone.

Rectangular top mount or wall mount glossy or matt Ceramilux sink complete with drain pipe fitting and open plug.

H	P	L	art.
50	50	90	GEST033590

Porta lavabo con 2 cassetti Art. SLIM di cui 1 sagomato internamente per sifone, abbinabile solo con lavabo Art. GEST090.

Sink unit with 2 drawers Art. SLIM, one of which internally shaped for siphon, to be combined with sink Art. GEST090.



lavabi / sinks

GEST0126 + GEST0335126

H	P	L	art.
13	50	126	GEST0126

Lavabo rettangolare sopra piano o da parete in Ceramilux lucido o opaco completo di piletta con scarico libero e raccordo per sifone.

Rectangular top mount or wall mount glossy or matt Ceramilux sink complete with drain pipe fitting and open plug.

H	P	L	art.
50	50	126	GEST0335126

Porta lavabo con 2 cassetti Art. SLIM di cui 1 sagomato internamente per sifone, abbinabile solo con lavabo Art. GEST0126.

Sink unit with 2 drawers Art. SLIM, one of which internally shaped for siphon, to be combined with sink Art. GEST0126.



SLOT design Nevio Tellatin

Ha cambiato il modo di concepire il lavabo, ha ridefinito l'archetipo di un suo componente meramente funzionale trasformandolo in strumento compositivo del progetto, ha sancito l'inizio di un nuovo percorso, quello del minimalismo assoluto.

Pulito, essenziale, rigoroso, moderno. In una sola parola Slot. Il Corian come materiale d'elezione con il suo uniforme candore e la setosa superficie da toccare, il disegno come regola da seguire. Forme nette, linee squadrate, spigoli vivi e ampiezza dei bordi ma soprattutto totale assenza della piletta, del troppopieno, di tutto ciò che in qualche modo può offuscare la perfetta estetica dell'oggetto. Rimane una fessura, un taglio nella parte posteriore del bacino, un'apertura sottile che corre lungo tutto lo sviluppo del lavabo e accoglie l'acqua grazie all'impercettibile inclinazione del fondo, nascondendo alla vista il sifone integrato. Le parti tecniche sono invisibili, l'acqua defluisce lungo una scanalatura lineare, l'immagine del lavabo rimane pulita, assoluta, essenziale.

A different way of conceiving a sink redefining the archetype of its purely functional component of the project, transforming it into a compositional tool, marks the beginning of a new path, that of absolute minimalism.

Clean, essential, rigorous, modern. In one word Slot. Corian as a material of choice with its uniform whiteness and silky surface to touch, such as the design rule to follow. Net shapes, square lines, sharp edges and width of the borders but total absence of drain, overflow, of all that can somehow confuse the perfect aesthetics of the object. It remains a slit, a cut in the rear part of the basin, a thin opening that runs along the whole development of the basin and accommodates the water through the imperceptible inclination of the bottom, hiding the integrated siphon. The technical parts are invisible, water flows along a linear slot, the sink image remains clean, absolute, essential.





lavabi / sinks

SLOT

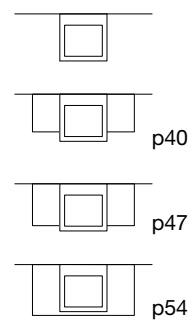
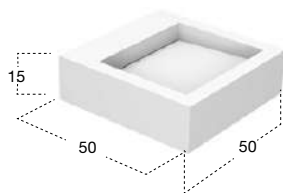

H	P	L	art.
15	50	50	SLOT21

Lavabo quadro sopra piano o da parete in Corian, con sifone incorporato.

Square top or wall mount Corian sink, with incorporated trap.



lavabi / sinks

SLOT22

SLOT23

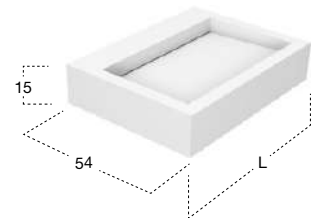
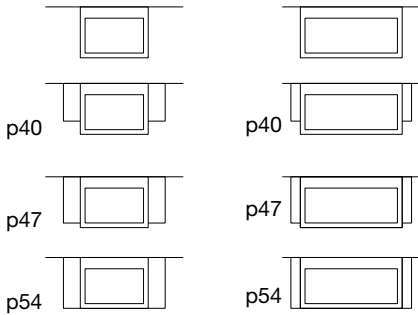

H	P	L	art.
15	54	72	SLOT22
	54	108	SLOT23

Lavabo rettangolare sopra piano o da parete in Corian, con sifone incorporato.

Rectangular top or wall mount Corian sink, with incorporated trap.



LAVANDINO design Francesca Braga Rosa, Ivano Vianello

Sottile come un foglio, essenziale come una figura geometrica bidimensionale, leggero ma solido, all'apparenza sospeso in aria ma in realtà ben ancorato alla parete. Minimale ma espressivo.

Il nome è volutamente semplice, quasi ingenuo, facilmente associabile alla sua funzione, il tratto è essenziale, il materiale non usuale. La semplicità di un foglio piegato e la purezza dell'acciaio inox sono l'ispirazione di Lavandino, il lavabo dalla forma nitida, dalla geometria assoluta, dal rigore che si trasforma in espressività. Geometria assoluta anche per il rubinetto rettangolare e le manopole cilindriche, collocati in posizione asimmetrica per esaltare il senso di dinamismo trasmesso dall'immagine complessiva del lavabo.

Sembra sospeso ma nasconde una tecnologia avanzata che permette al lavabo di integrarsi alla parete grazie a un telaio, che funge da dima per la finitura, e che consente l'alloggio della cartuccia del rubinetto. La leggerezza è immediata, la perfetta continuità del materiale è garantita da saldature eseguite a regola d'arte, l'acqua viene fatta defluire da un taglio sulla superficie che sottolinea il linguaggio essenziale del progetto.

Thin as a sheet of paper, essential as a two-dimensional geometric shape, light but solid, seemingly suspended in the air but really well anchored to the wall. Minimal yet expressive.

The name is deliberately simple, almost naive, easily associated to its function, essential lines, the unusual material. The simplicity of a folded sheet and the purity of stainless steel are the inspiration for Lavandino, the sink with a sharp shape, absolute geometry, rigor that transforms into expressiveness. Absolute geometry even for the rectangular tap and the cylindrical knobs, placed in an asymmetrical position to enhance the sense of the dynamics transmitted from the overall image of the sink.

It seems suspended but hides an advanced technology that allows the sink to integrate to the wall thanks to a frame, which serves as a template for the finishing, and that allows the accommodation of the faucet cartridge. Lightness is immediate, the perfect continuity of the material is guaranteed by welding performed in a workmanlike manner, the water is allowed to flow from a cut on the surface that emphasizes the essential language of the project.

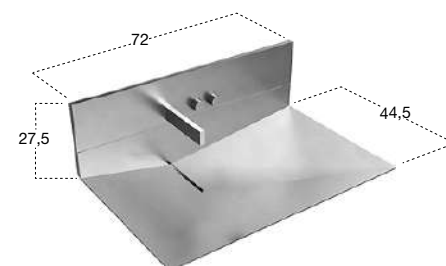

H	P	L	art.
27,5	44,5	72	LAVANDINO

Lavabo rettangolare da parete in acciaio inox AISI 316/L completo di rubinetteria, scarico libero e raccordo per sifone.

Rectangular wall mount stainless steel AISI 316/L sink, complete with tap, drain pipe fitting and open plug.





PIXEL design Paolo Ulian

Modello e design registrato, brevetto depositato
Registered model and design, patent filed

Dalla materia più antica all'illusione di dare forma all'immateriale, dalla tradizione scultorea del "tutto tondo" alla suddivisione in piccole parti delle superfici per dar vita a un volume che è espressione della "sottrazione" di tanti piccoli punti. Il nome dice tutto: un pixel è un elemento puntiforme che compone un'immagine digitale, è insomma l'elemento più piccolo che la costituisce. La scomposizione in singoli pixel della superficie, una sorta di mosaico tridimensionale, conferisce un aspetto inedito al lavabo in marmo Pixel. Una forma che nasce per sottrazione, un'idea dell'uomo che prende vita grazie all'impiego della macchina e viene poi definita nel suo aspetto finale ancora attraverso le scelte dell'uomo. Tradizione e tecnologia si incontrano in una forma unitaria scomposta, sezionata, solcata da un reticolo ortogonale, un volume cilindrico sul quale la macchina ha tracciato un segno netto e preciso secondo un progetto che lascia aperte infinite possibilità compositive, un lavabo freestanding che cambia continuamente volto perché eliminando i tasselli l'immaginazione prende forma, l'immagine si rivela, l'essenza viene alla luce. Luci e ombre, profondità e rilievi, accostamenti e lontananze, connessioni e isolamenti. Il gioco dei pixel che formano il lavabo è tutto orientato sulla consequenzialità, sulla prossimità, sul decoro che nasce dalla materia stessa. Un gesto, quello della sottrazione, che rivela la forma, che permette di personalizzare il volume, che amplifica la concezione tridimensionale del progetto. Pixel è sottrarre per comporre.

From the oldest material to the illusion of shaping the immaterial, from the sculptural tradition of the "well-rounded" shapes to the division in small parts of the surface to create a volume that is an expression of the "subtraction" of many small pieces. The name says it all: a pixel is a point-like element that makes up a digital image, in fact, it is the smallest element that constitutes it. The breakdown in individual pixels of the surface, a kind of three-dimensional mosaic, gives an unprecedented look at the marble sink Pixel. Shape is created by subtraction, man's idea that comes to life through the use of the machine that is then defined in the end again through man's choices. Tradition meets technology in a decomposed standardized form, sectioned, intersected by an orthogonal lattice, a cylindrical volume on which the machine has mapped out a clear and definite sign according to a project that leaves open endless possibilities of composition. A freestanding ever-changing sink due to the elimination of pieces imagination can take shape, the image is revealed, the essence comes to light. Lights and shadows, depth and reliefs, combinations and distances, connections and insulation. The pixel game that forms the basin is completely oriented on consequentality, on proximity, on decorum that comes from the material itself. A gesture, that of subtraction, revealing the shape, which allows you to customize the volume, and which amplifies the three-dimensional design of the project. Pixel is subtraction to compose.

PIXEL

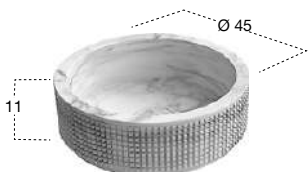
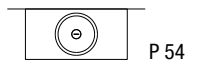

H	Ø	art.	
11	45	PIXEL45	Marmo Carrara

Lavabo tondo sopra piano in pietra, completo di piletta con scarico libero e raccordo per sifone.

Round top mount stone sink complete with drain pipe fitting and open plug.



lavabi / sinks





lavabi / sinks

P 54

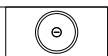

	H	Ø	art.
Marmo Carrara	16	45	INTROVERSO45

Lavabo tondo sopra piano in pietra, completo di piletta con scarico libero e raccordo per sifone.

Round top mount stone sink complete with drain pipe fitting and open plug.

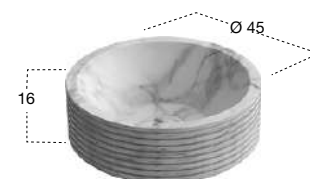





lavabi / sinks

BLOKKO

BLOKKO11

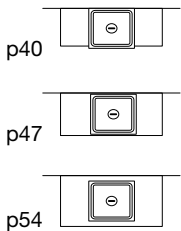

BLOKKO

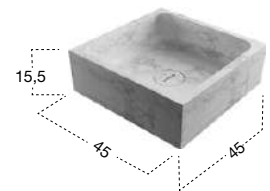

BLOKKO11

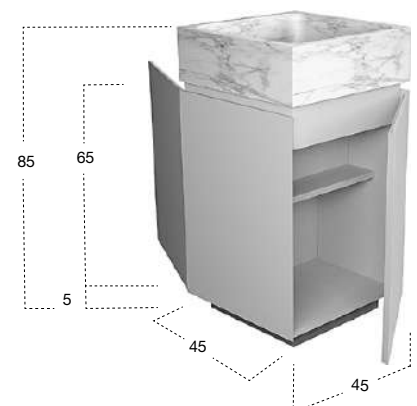

	H	P	L	art.
Marmo Carrara	15,5	45	45	BLOKKO

Lavabo quadro sopra piano in pietra, completo di piletta con scarico libero e raccordo per sifone.

Square top mount stone sink, complete with drain pipe fitting and open plug.

	H	P	L	art.
	85	45	45	BLOKKO11

Centro stanza con 2 ante, 1 posteriore e 1 anteriore dx o sx e 1 ripiano interno in legno, completo di zoccolo nero goffrato, e lavabo in Marmo di Carrara.

Freestanding cabinet with 2 doors, front and back right or left and one internal wooden shelf, complete with plinth lacquered embossed black and Carrara Marble sink.

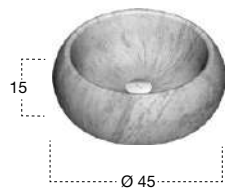
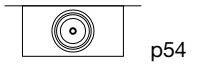

H	Ø	art.	
15	45	BULL	Pietra Sinai

Lavabo tondo sopra piano in pietra, completo di piletta con scarico libero e raccordo per sifone.

Round top mount stone sink complete with drain pipe fitting and open plug.



Pietra Vesuvio

lavabi / sinks

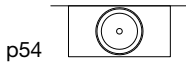

	H	Ø	art.
Pietra Luna / Pietra Vesuvio / Nero Marquina	15	50	PILA11

Lavabo tondo sopraiano in pietra, completo di piletta con scarico libero e raccordo per sifone.

Round top mount stone sink complete with drain pipe fitting and open plug.



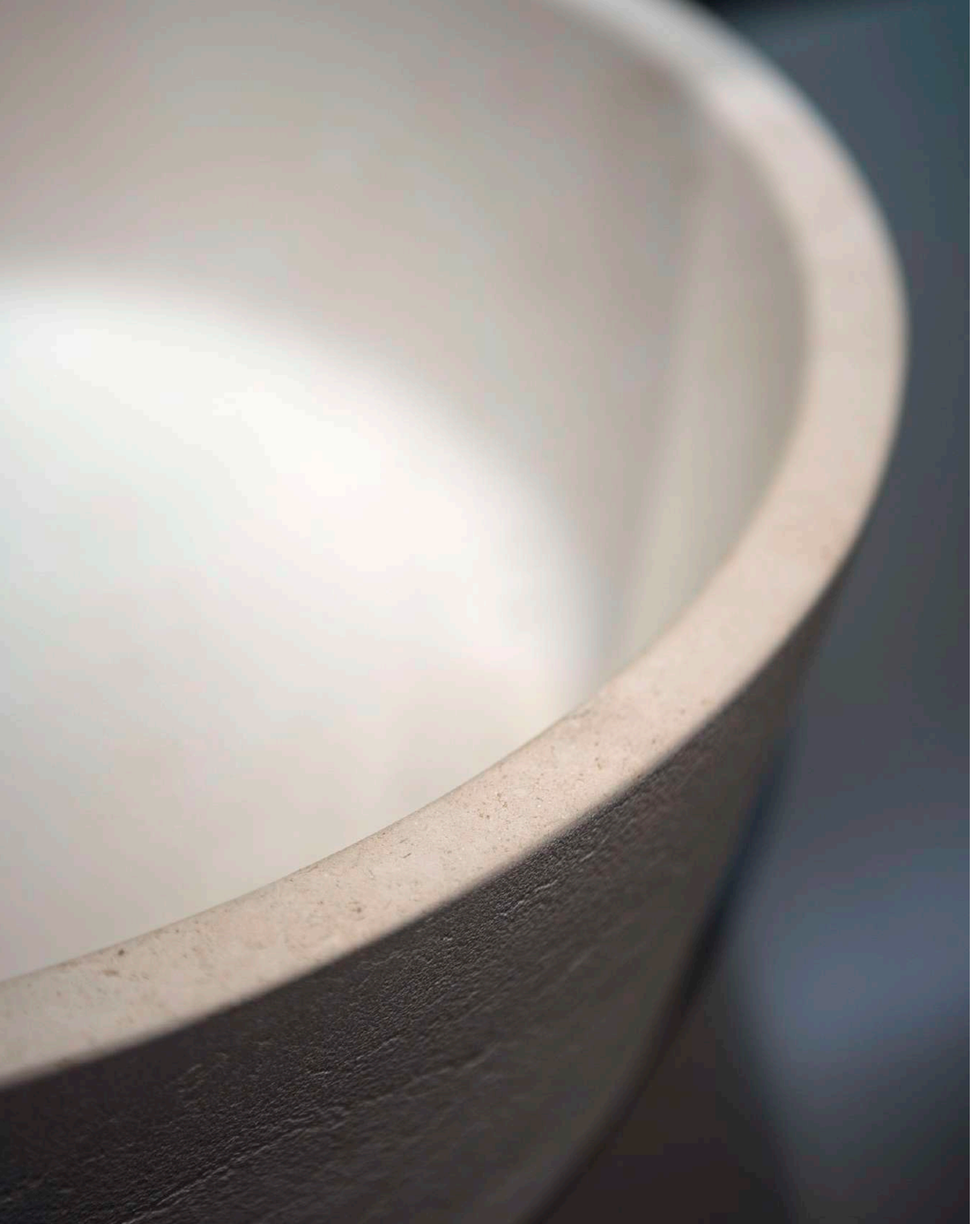



Pietra Luna

lavabi / sinks

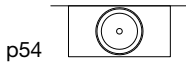

	H	Ø	art.
Pietra Luna / Pietra Vesuvio / Nero Marquinia	15	50	PILA11

Lavabo tondo sopra piano in pietra, completo di piletta con scarico libero e raccordo per sifone.

Round top mount stone sink complete with drain pipe fitting and open plug.



AGO design Mario Ferrarini

La forma è fluida e iconica, la sottigliezza del bordo esalta la naturalità dell'immagine finale, la continuità delle linee evidenzia un dna organico che ammorbidisce le geometrie assolute.

Una nuova versione che esprime tutte le potenzialità del gesto, che valorizza al meglio il design elegante e armonico della collezione. Un'identità forte e allo stesso tempo naturale che trova nell'impiego del nuovo materiale, un prezioso alleato per la lettura complessiva del progetto. Ago85, realizzato in Flumood, è la sintesi armonica di volumi essenziali, è l'incontro virtuoso tra la geometria perfetta del bacino circolare dai bordi sottili e la base cilindrica che si restringe verso l'alto. Proprio la delicatezza con cui è risolto il raccordo tra base e bacino, è il tratto essenziale della collezione e in particolare di questo lavabo freestanding che diventa il fulcro di un ambiente bagno contemporaneo e trasversale.

Shape is fluid and iconic, the thinness of the edge enhances the naturalness of the final image, the continuity of the lines shows an organic DNA that softens the absolute geometries.

A new version that expresses the potential of the gesture which enhances the best elegant and harmonious design of the collection. A strong yet natural identity that when using the new material is a valuable ally for the overall interpretation of the project. Ago85, made from Flumood, is the harmonious synthesis of essential volumes, is the virtuous encounter between the perfect geometry of the circular basin with thin edges and the cylindrical base that narrows upwards. Just the delicacy with which it solves the connection between the base and the basin is the essential feature of the collection, and in particular of this freestanding washbasin that becomes the focus of a contemporary and transversal bathroom.



LAVABI / SINKS
FREESTANDING



lavabi / sinks
freestanding





Verniciabile esternamente in tutti i colori del nostro campionario
Can be externally lacquered in all colors of our collection

lavabi / sinks
 freestanding

H	Ø	art.
85	50	AG085

Lavabo da terra in Flumood con scarico a pavimento, completo di piletta con scarico libero, sifone e tubo flessibile.

Freestanding Flumood sink with floor drainage complete with open plug, siphon and flexible hose.



SIMPLO design Mario Ferrarini

Modello e design registrato, brevetto depositato
Registered model and design, patent filed

Un volume cilindrico perfetto, un lavabo freestanding che pur nelle dimensioni compatte occupa la scena con personalità e rigore. Il piano è integrato nel bacino ma fuori non ci sono orpelli o decori. Semplice come dice il nome, essenziale nell'esprimere una geometria perfetta, iconico, nel presentarsi come totem attorno al quale organizzare lo spazio. Simplo85 è realizzato in Flumood e si sviluppa da terra con un corpo cilindrico sulla cui sommità, il bacino del lavabo, viene in parte tagliato e occupato da un utilissimo piano d'appoggio. Disponibile nella versione total white o con la superficie esterna goffrata disponibile nelle tonalità della gamma antoniolupi o a richiesta su campione del cliente.

A perfect cylindrical volume, a freestanding sink that despite being compact occupies space with personality and rigor. The surface is integrated in the basin and the outer shape completely clean. Simple as the name implies, essential in its geometrical shape, iconic and presents itself as a totem around which to organize the space. Simplo85 is made from Flumood, cylindrical in shape with the basin partially cut out and an integrated surface. Available in all white or two toned with the outer surface embossed lacquered available in all the antoniolupi colours or by request in another colour.





COLORI / COLOURS

lavabi / sinks
freestanding

SIMPLO





lavabi / sinks
freestanding





Verniciabile esternamente in tutti i colori del nostro campionario
Can be externally lacquered in all colors of our collection

lavabi / sinks
 freestanding

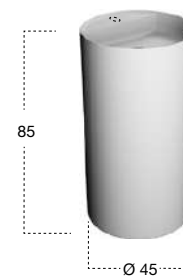

H	Ø	art.
85	45	SIMPL085

Lavabo da terra in Flumood con scarico a pavimento, completo di piletta con scarico libero sifone e tubo flessibile.

Freestanding Flumood sink with floor drainage complete with open plug siphon and flexible hose.

FUSTO design Nevio Tellatin

Un totem assoluto, rigoroso, essenziale. Un lavabo dai bordi sottili, impreziosito da un elemento accessorio elegante e discreto che sottolinea la forma e ne aumenta la funzionalità

Come Simplo ha nell'elemento accessorio un componente distintivo del progetto che assume un valore che va al di là della vera funzionalità. Fusto è il lavabo freestanding realizzato in Flumood dalla geometria rigorosa e dalle linee nette e precise. Una barra porta salviette, corre lungo due lati del lavabo sottolineandone la forma e definendo l'angolo. La sezione piatta trasmette continuità con il resto della composizione. Disponibile nella versione total white o con la superficie esterna goffrata disponibile nelle tonalità della gamma antoniolupi o a richiesta su campione del cliente.

An absolute totem, rigorous and essential. A sink with thin edges embellished with an elegant accessory discrete and subtle in form increasing its functionality.

As Simple this sink has a distinctive component of the project adding value and going beyond its functionality. Fusto is a freestanding sink made of Flumod with net precise lines. A towel bar runs along both sides of the basin underlining its shape and defining the corner. Available in either all white or embossed lacquered available in all the antoniolupi colours or by request in another colour.

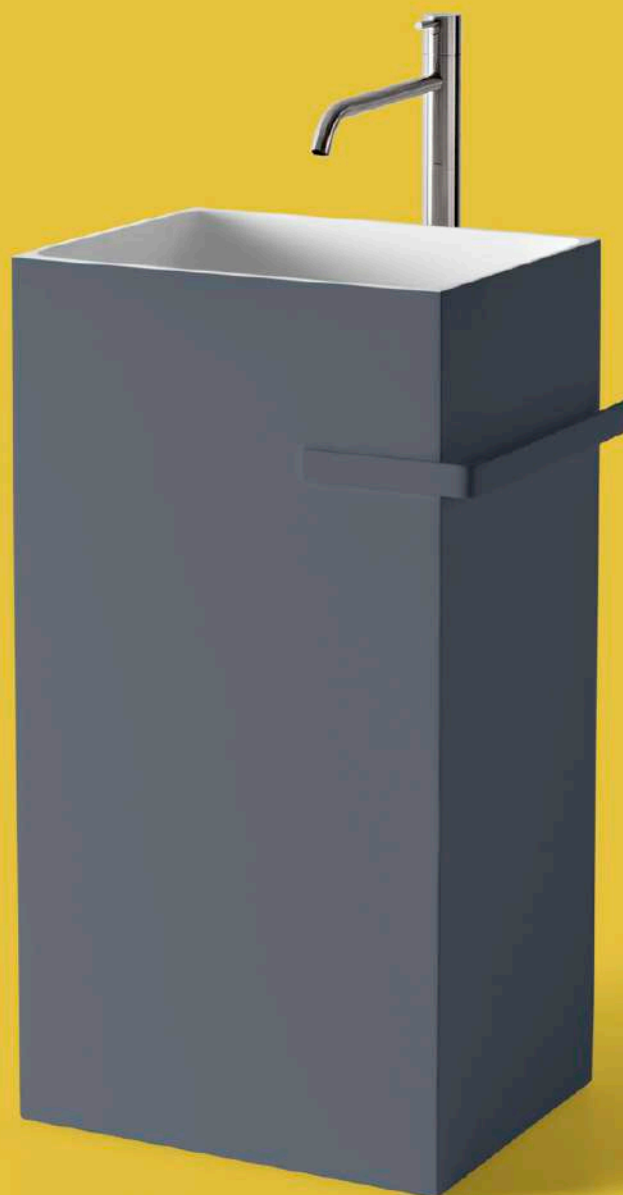



lavabi / sinks
freestanding

FUSTO





lavabi / sinks
freestanding





Verniciabile esternamente in tutti i colori del nostro campionario
Can be externally lacquered in all colors of our collection

FOLDVE

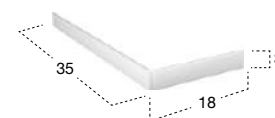

lavabi / sinks
 freestanding

FUSTO

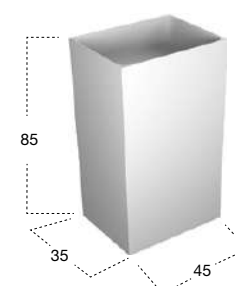

H	P	L	art.
85	35	45	FUSTO

Lavabo da terra in Flumood con scarico a pavimento, completo di piletta con scarico libero sifone e tubo flessibile.

Freestanding Flumood sink with floor drainage complete with open plug siphon and flexible hose.

H	P	L	art.
3	35	18	FOLDVE

Porta salviette in acciaio inox AISI 304 verniciato gofrato come da nostra cartella colori laccati.

Towel holder in stainless steel AISI 304 embossed lacquer finish as per our colour chart.

TUBA design Carlo Colombo

Si apre come stelo di un fiore, stupisce per la forma organica e per le diverse posizioni che può assumere proponendo un'immagine sempre diversa, caratterizza lo spazio, senza essere troppo invadente. Si sviluppa in altezza allargandosi a partire dalla base tonda per aprirsi e accogliere con un gesto avvolgente lo scorrere dell'acqua. Tuba, realizzato in Cristalplant, rimanda a un'immagine estremamente naturale e si inserisce al meglio in atmosfere sofisticate dialogando con elementi dal forte impatto scenico. Nella versione freestanding propone una sezione diagonale che conferisce un aspetto inedito al bordo del bacino, mentre il suo aspetto scultoreo rivela un'espressione formale mutevole in base ai punti di osservazione. La versione verniciata esternamente, sottolinea il carattere a tutto tondo del lavabo evidenziando la perfetta geometria circolare della sommità.

Opens like the stem of a flower, it is surprising for its organic form and how it characterizes the space, without being too intrusive.

It develops into height from a round base to open up and accept with an enveloping gesture the flow of water. Tuba, made from Cristalplant, leads to an extremely natural and sophisticated atmospheres with elements with a strong visual impact. In the freestanding version proposes a diagonal section that gives a new aspect to the edge of the basin, while its sculptural appearance reveals a changing formal expression based on the observation points. The external lacquered version, emphasizes the character highlighting the perfect circular geometry of the summit.





lavabi / sinks
freestanding





Verniciabile esternamente in tutti i colori del nostro campionario
Can be externally lacquered in all colors of our collection

lavabi / sinks
 freestanding

H	Ø	art.
90	50,4	TUBA3

Lavabo da terra in Cristalplant con scarico a pavimento, completo di piletta con scarico libero, sifone e tubo flessibile.

Freestanding Cristalplant sink with floor drainage complete with open plug, siphon and flexible tube.

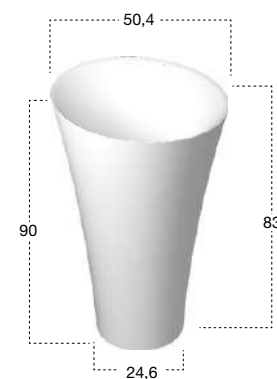

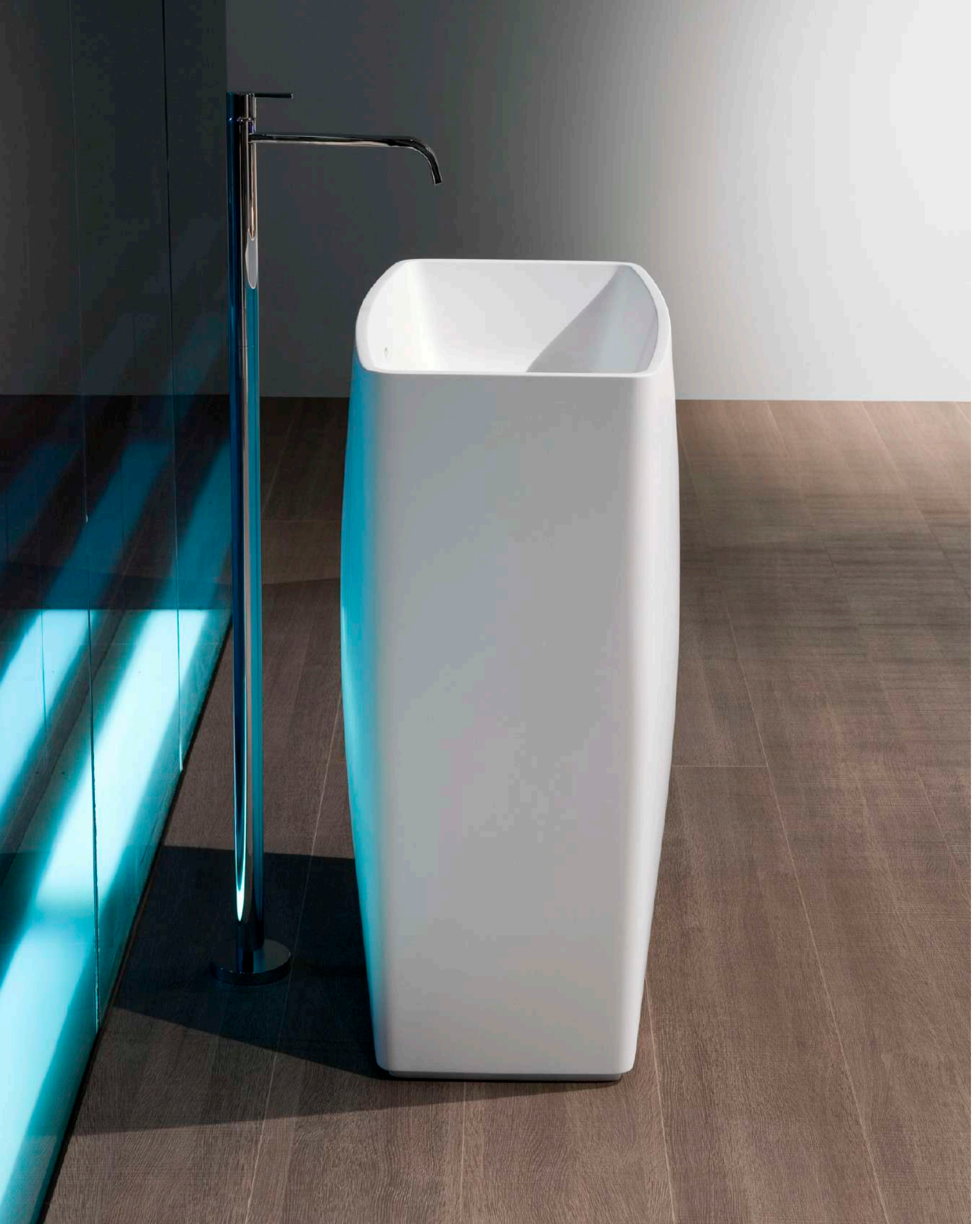



TENDER design Carlo Colombo

Un'originale forma schiacciata, una profondità contenuta, un'immagine inedita per un lavabo freestanding dalla sezione rettangolare addolcita da morbide linee curve. All'inizio c'è un effetto sorpresa, quasi di spaesamento perché al tradizionale asse verticale dei lavabi freestanding viene associato uno sviluppo longitudinale. Poi l'immagine di Tender ritorna amica, conosciuta come quella di un vaso in cui la geometria del rettangolo viene ammorbidita da angoli smussati e linee leggermente arcuate. Un oggetto monolitico, dalla staticità assoluta, che muta il proprio aspetto e le proprie valenze espressive quando viene proposto in Cristalplant o in pietra, con la quale ritorna l'immagine del blocco scavato dall'acqua e plasmato dalle mani sapienti dell'uomo.

An original flat shape, deep, unexpected image for a freestanding washbasin with a rectangular section softened by soft curved lines. At the beginning there is a surprise, almost of bewilderment because the traditional vertical axis of freestanding basins is associated to a longitudinal development. Then the image of Tender returns friend, known as that of a vessel in which the rectangular geometry is softened by rounded corners and slightly curved lines. A monolithic object, from the absolute stillness, that changes its appearance and its expressive power when it is proposed in Cristalplant or stone, with which returns the image of a block carved by water and shaped by the hands of artisans.

H	P	L	art.
85	41	72	TENDER

Lavabo da terra in Cristalplant con scarico a pavimento, completo di piletta con scarico a pressione klik-clak, sifone e tubo flessibile.

Freestanding Cristalplant sink with floor drainage complete with pressure plug, siphon and flexible hose.

Verniciabile esternamente in tutti i colori del nostro campionario
Can be externally lacquered in all colors of our collection

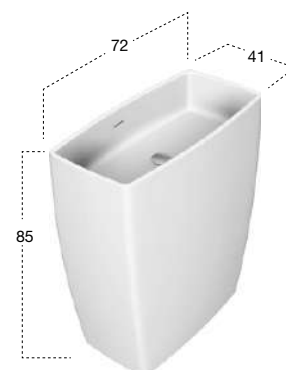

lavabi / sinks
freestanding





BARREL design Carlo Colombo

Le forme bombate, l'immagine che rimanda all'archetipo del barile di legno, la figura massiccia, imponente, iconica nel suo sviluppo a tutto tondo e nella superficie perfettamente levigata. Occupa lo spazio imponendo fin da subito una gerarchia precisa a tutta la composizione, catturando il centro della scena. Nella sua versione originale accoglie alcolici, che preserva a lungo proteggendoli. Come lavabo invece è l'acqua a essere contenuta, non conservata, al suo interno. Barrel attua una trasposizione di funzione all'interno dello spazio domestico, mantenendo i caratteri di un'immagine amica con le sue forme bombate con la base ridotta a dare stabilità e a definire l'appoggio a terra del "barile". Disponibile in Cristalplant o pietra.

Rounded shapes, the image that points to the archetype of the wooden barrel, the massive figure, impressive, iconic in its all-round development and a perfectly smooth surface.

It occupies the space imposing immediately a precise hierarchy to the entire composition, capturing center stage. In its original version it held alcohol and preserved it for a long time protecting it. As washbasin instead the water is to be contained, not conserved, in its interior. Barrel implements a transposition function within the domestic space, maintaining the character of a pleasing picture rounded form with the reduced base to provide stability and support on the ground to define the "barrel". Available in Cristalplant or stone.

H	Ø	art.
85	65	BARREL3

Lavabo da terra in Cristalplant con scarico a pavimento, completo di piletta con scarico a pressione clik-clak, sifone e tubo flessibile.

Freestanding Cristalplant sink with floor drainage complete with pressure plug, siphon and flexible hose.

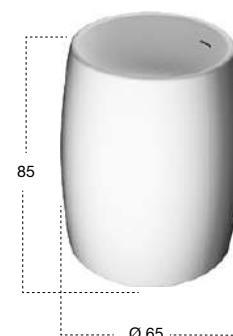





MR. SPLASH design Jorge Bibiloni

Ironico, divertente, fuori dagli schemi. Pochi gesti: uno schermo arcuato e un piano inclinato che lo incontra, per una forma che nasconde un bacino dalle dimensioni contenute e lo rivela solo lateralmente. L'acqua scorre sul piano inclinato a sbalzo come su un lavatoio, la gravità la trascina verso il bacino ma a un certo punto scompare dalla nostra vista. Uno schermo arcuato, un diaframma protegge il suo flusso e nasconde il bacino, proteggendo un bene così prezioso. L'immagine è ironica e inusuale, la genesi lascia spazio a diverse interpretazioni, la forma è determinata dall'intersezione di geometrie diverse. Mr. Splash è un lavabo freestanding dallo spessore contenuto, un oggetto dinamico che cattura l'attenzione e invita ad avvicinarsi, a guardare dentro...

Ironic, fun, outside of the box. Few gestures: an arched screen and an inclined plane which meets for a form that hides a basin with small dimensions and only the side reveals. Water flows on the inclined plane, gravity drags her toward the basin, but at some point disappears from sight. An arched screen, a diaphragm protects its flow and conceals the basin, protecting such a precious resource. The image is ironic and unusual, the genesis leaves room for different interpretations, the shape is determined by the intersection of different geometries. Mr. Splash is a freestanding washbasin by reduced thickness, dynamic object that captures the attention and invites them to approach, to look inside ...

H	P	L	art.
100	44	72	MR.SPLASH

Lavabo da terra in Cristalplant con scarico a pavimento, completo di piletta con scarico libero, sifone e tubo flessibile.

Freestanding Cristalplant sink with floor drainage complete with open plug, siphon and flexible hose.

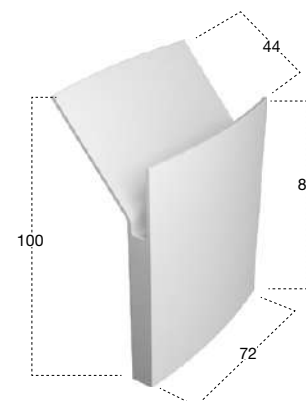

lavabi / sinks
freestanding





lavabi / sinks
freestanding

Nero Marquinia





lavabi / sinks
freestanding

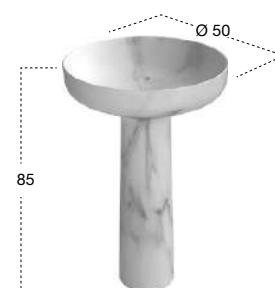

	H	Ø	art.
Marmo Carrara / Nero Marquina	85	50	AG0185

Lavabo da terra in pietra con scarico a pavimento, completo di piletta con scarico libero, sifone e tubo flessibile.

Peso lavabo: 57 kg ca.

*Freestanding stone sink with floor drainage complete with open plug, siphon and flexible hose.
Sink weight: 57 kg approx.*

CONTROVERSO design Paolo Ulian

Modello e design registrato, brevetto depositato
Registered model and design, patent filed

La tecnologia incontra la natura, l'evoluzione mantiene viva la memoria, il progetto permette di raccontare una storia. La forma viene generata per sottrazione come in una scultura, antica e contemporanea allo stesso tempo. Controverso nasce dal pensiero, dall'azione e trasforma il prodotto in esperienza. Un blocco di marmo viene solcato dalle fresature della macchina e poi interpretato dalla mano dell'uomo per dare vita a forme diverse.

Una proposta che nasce dal rispetto per la natura condiviso da Paolo Ulian e antoniolupi, un percorso sul marmo declinato in diverse collezioni che si inseriscono nel solco tracciato dai maestri che da sempre hanno interpretato questo materiale nobile.

Controverso è un monolite in marmo dalla forma stereometrica, squadrata, che viene lavorato per far esplodere tutta la sua forza intrinseca. Un gesto forte e delicato allo stesso tempo, un'interpretazione dell'atto creativo che incontra la produzione, un lavabo che trova posto in ambienti contemporanei ma anche in contesti diversi.

Technology meets nature, evolution keeps memory alive, the project allows you to tell a story. The form is generated by subtraction as in a sculpture, ancient and contemporary at the same time. Controverso springs from a thought, from action and transforms the product into an experience. A marble block is crossed by the milling machine and then interpreted by man to create different shapes.

A proposal that comes from respect for nature shared by Paolo Ulian and antoniolupi, a path with marble in different collections that fit into a path traced by masters that have always interpreted this noble material.

Controverso is a marble monolith of geometrical shape, squared, which is processed to detonate all its inherent strength. A strong and delicate gesture at the same time, an interpretation of the creative act that meets production, a sink that fits into contemporary environments but also in different contexts.





CONTROVERSO

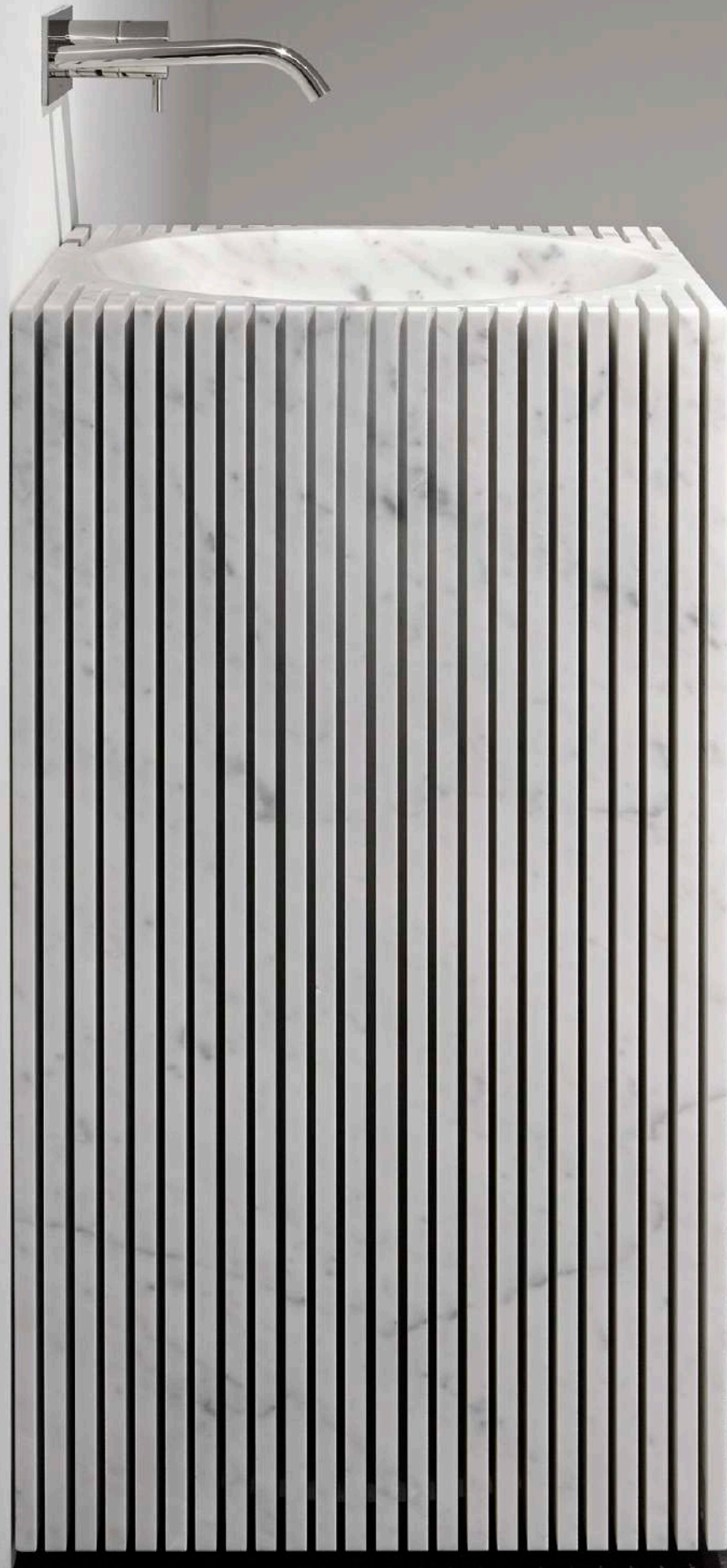



lavabi / sinks
freestanding





lavabi / sinks
freestanding

CONTROVERSO



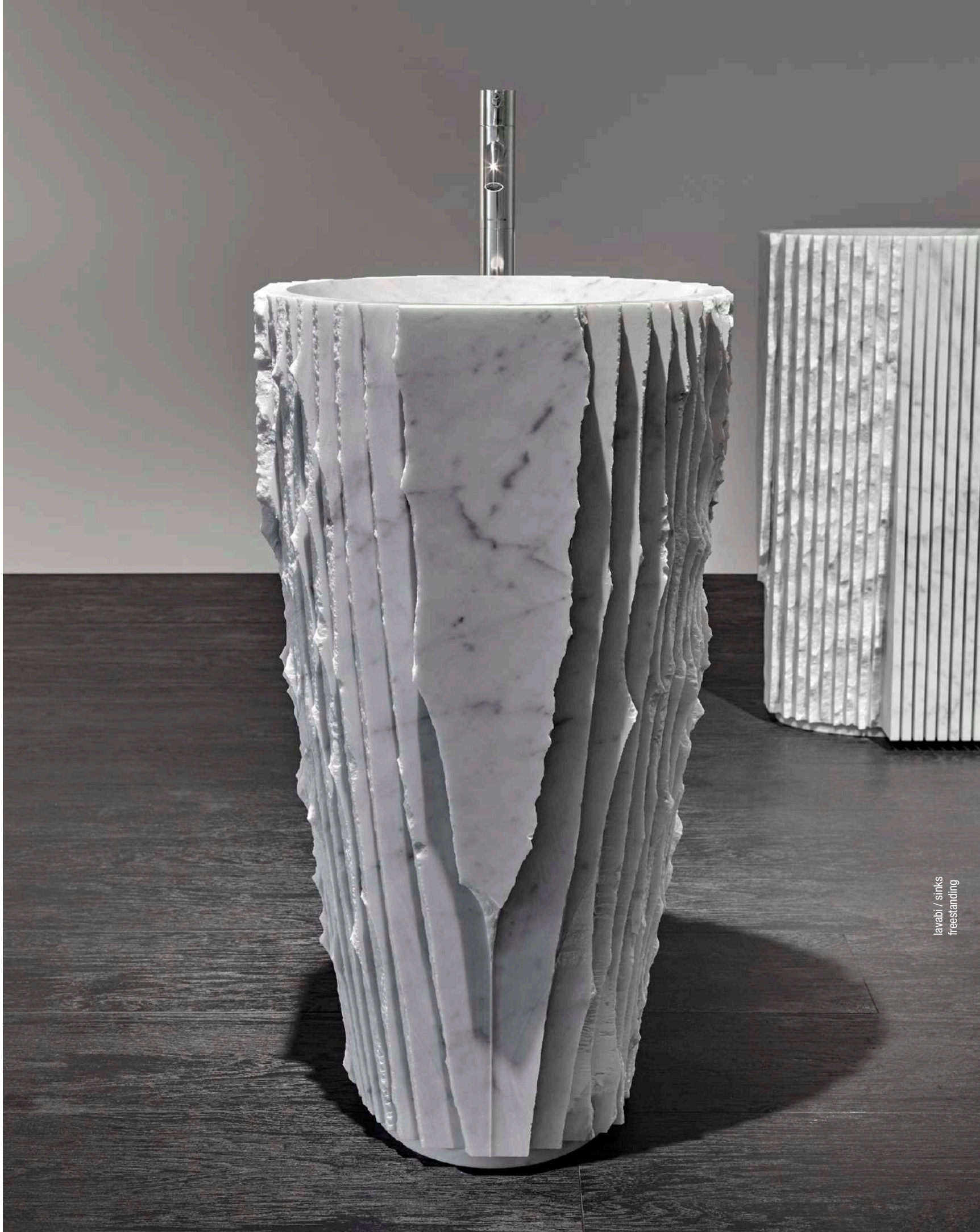

lavabi / sinks
freestanding

CONTROVERSO

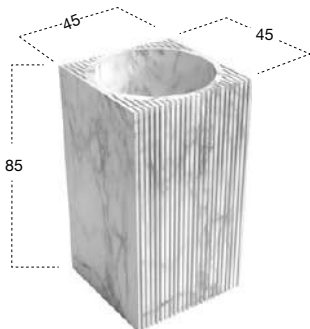

H	P	L	art.	
85	45	45	CONTROVERSO	Marmo Carrara

Lavabo da terra in pietra con scarico a pavimento, completo di piletta con scarico libero, sifone e tubo flessibile.
Peso lavabo: 361 kg ca.

*Freestanding stone sink with floor drainage complete with open plug, siphon and flexible hose.
Sink weight: 361 kg approx.*



lavabi / sinks
freestanding

PIXEL design Paolo Ulian

Modello e design registrato, brevetto depositato
Registered model and design, patent filed

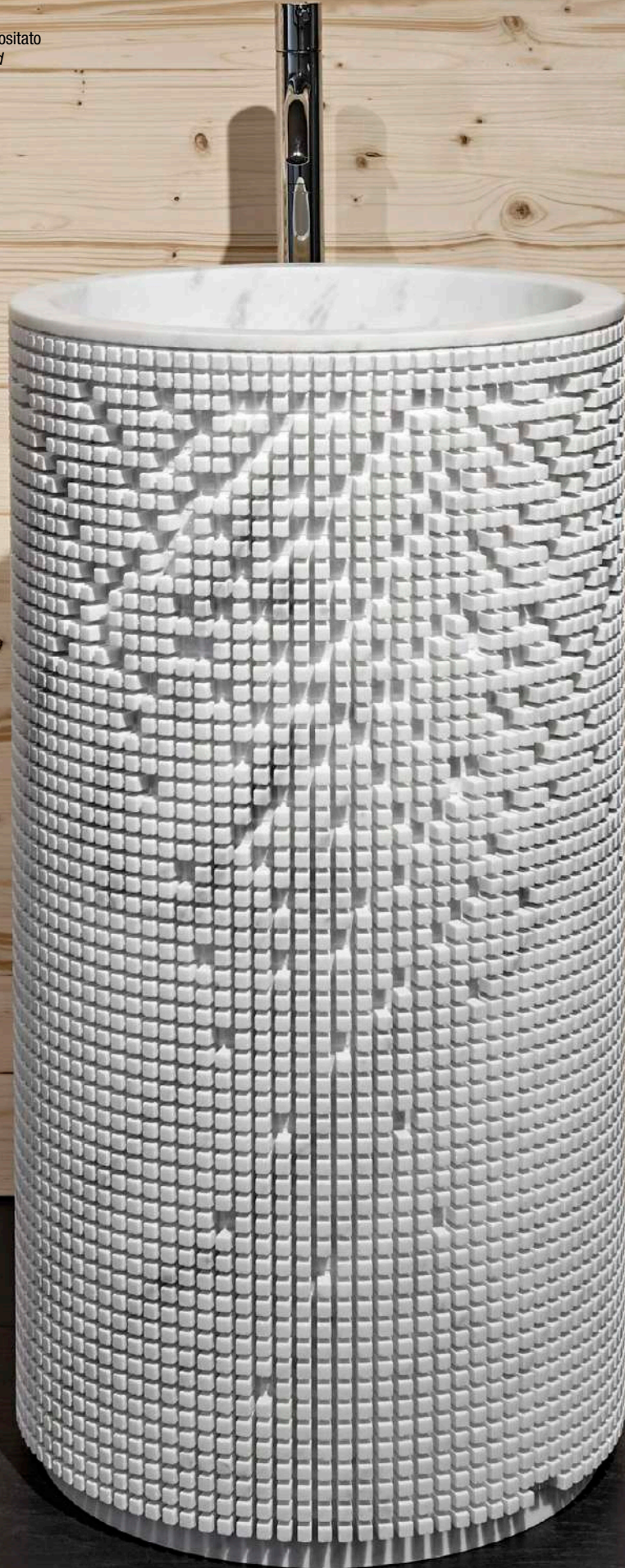



lavabi / sinks
freestanding

PIXEL

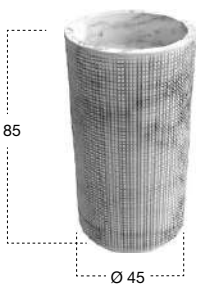

H	Ø	art.
85	45	PIXEL

Marmo Carrara

Lavabo da terra in pietra con scarico a pavimento, completo di piletta con scarico libero, sifone e tubo flessibile.
Peso lavabo: 177 kg ca.

*Freestanding stone sink with floor drainage complete with open plug, siphon and flexible hose.
Sink weight: 177 kg approx.*



lavabi / sinks
freestanding

INTROVERSO design Paolo Ulian

Modello e design registrato, brevetto depositato
Registered model and design, patent filed

La forma dentro la forma è stata l'idea che ha accompagnato sin dall'inizio il progetto Introverso di Paolo Ulian per antoniolupi. Un progetto nato osservando la lavorazione di sbizzo delle sculture di marmo, in cui la forma tridimensionale è delineata da una serie regolare di tagli gestiti da una macchina a controllo numerico. Si vengono in questo modo a formare sottili lamelle di marmo, i cui bordi esterni una volta spezzati, svelano la scultura grezza celata al suo interno.

Stesso concetto e medesima lavorazione sono declinate nella realizzazione del lavabo Introverso: un blocco di marmo bianco Carrara, tornito e alleggerito da una serie di tagli che lasciano intravedere la sua anima interna, la forma dentro la forma.

Il blocco di marmo perde il suo aspetto monolitico e si trasforma in qualcosa di etereo, trasparente, che racchiude un'anima segreta. Anima che può rimanervi nascosta, lasciandosi intravedere dai sottili giochi di luce, o può essere lentamente svelata spezzando i bordi delle lamelle.

The shape within the form was the idea that accompanied from the very beginning the project by Paolo Ulian for antoniolupi. A project born by observing the first rough draft by machine of marble sculptures, in which the three-dimensional shape is outlined by a regular series of cuts managed by a numerical controlled machine. Thin strips of marble are formed, whose outer edges once broken, reveal the raw sculpture concealed inside.

The same concept and process are used in the realization of the Introverso sink: a white Carrara marble block, machined and lightened by a series of cuts that reveal its internal core, the shape inside the shape.

The marble block loses its monolithic appearance and is transformed into something ethereal, transparent, enclosing a core secret. A soul that can remain hidden, leaving a glimpse of the subtle play of light, or it may be slowly unveiled by breaking the edges of the blades.





INTROVERSO



a01/1,8



a02/1,8



a03/1,5





a04/1,5



a05/2,6



a06/2,2



lavabi / sinks
freestanding

Sulla parete, opere a tema architettonico di BENIAMINO SERVINO
On the wall, themed architectural works by BENIAMINO SERVINO

INTROVERSO

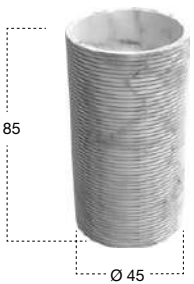

H	Ø	art.	
85	45	INTROVERSO3	Marmo Carrara

Lavabo da terra in pietra con scarico a pavimento, completo di piletta con scarico libero, sifone e tubo flessibile.
Peso lavabo: 223 kg ca.

*Freestanding stone sink with floor drainage complete with open plug, siphon and flexible hose.
Sink weight: 223 kg approx*

lavabi / sinks
freestanding

	H	Ø	art.
Marmo Carrara	85	45	INTROVERSO2

Lavabo da terra in pietra con scarico a pavimento, completo di piletta con scarico libero, sifone e tubo flessibile.

Peso lavabo: 223 kg ca.

*Freestanding stone sink with floor drainage complete with open plug, siphon and flexible hose.
Sink weight: 223 kg approx.*

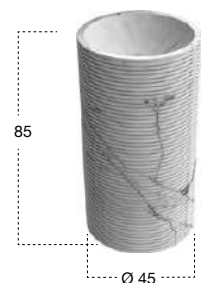

INTROVERSO

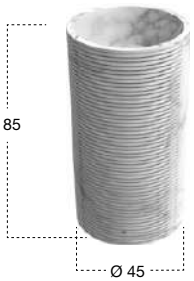

H	Ø	art.	
85	45	INTROVERSO1	Marmo Carrara

Lavabo da terra in pietra con scarico a pavimento, completo di piletta con scarico libero, sifone e tubo flessibile.
Peso lavabo: 223 kg ca.

*Freestanding stone sink with floor drainage complete with open plug, siphon and flexible hose.
Sink weight: 223 kg approx*



lavabi / sinks
free-standing

ATLANTE design Silvia Nerbi, Andrea Bogazzi

Un ready made, anzi una rifunzionalizzazione, cioè un cambio radicale della funzione alla quale siamo soliti associare un'immagine. Un segno forte e riconoscibile, una forma bella, in assoluto, al di là di soggettive interpretazioni. Tra architettura e design, tra classicismo dell'antica Grecia e creatività contemporanea, tra mito e rito. Atlante, che prende il nome dalla divinità greca che sorreggeva sulle proprie spalle la volta celeste, è un progetto complesso che indaga il senso delle cose, che esplora la rappresentatività della funzione, che ribalta un luogo comune di pensare, o meglio di vedere. Una colonna in marmo che diventa lavabo, un elemento che dovrebbe sostenere e invece contiene, un pilastro dell'architettura che diventa protagonista gerarchico dell'ambiente bagno, un volume pieno che diventa vuoto, per poi essere riempito. Realizzato interamente in marmo bianco di Carrara, Atlante è il lavabo da terra che gioca con l'immagine della colonna e in particolare del fusto che perde o meglio accantona la sua funzione strutturale per entrare nell'ambito domestico. La geometria circolare del bordo del bacino, la scansione modulare del volume determinata dalle scanalature tipiche della colonna classica, la perfetta armonia proporzionale; un salto di scala per un progetto dalla forte impronta architettonica.

Readymade, or rather a radical change of the normal function to which we associate an image. A strong and recognizable sign, a beautiful form absolutely beyond subjective interpretations. Between architecture and design, between classicism of ancient Greece and contemporary creativity, between myth and ritual. Atlante, which takes its name from the Greek god who was holding on his shoulders the vaults of heaven, is a complex project that investigates the meaning of things which explores the representation of the function, which overturns a commonplace to think, or rather to see. A marble column that becomes a sink, an element that should support and instead contains, a hierarchical architectural pillar becomes the star of the bathroom, a full volume that becomes empty, only to be filled. Made entirely of white Carrara marble, Atlante is the freestanding sink that plays with the image of the column and in particular the stem that loses or better shelve its structural function to enter in the home. The circular geometry of the border, the modular scanning of the volume determined by typical grooves of a classical column, perfect and proportional harmony; a leap for a project with a strong architectural imprint.





lavabi / sinks
freestanding

	H	Ø	art.
Marmo Carrara	85	51	ATLANTE2

Lavabo da terra in pietra con scarico a pavimento, completo di piletta con scarico libero, sifone e tubo flessibile.
Peso lavabo: 180 kg ca.

*Freestanding stone sink with floor drainage complete with open plug, siphon and flexible hose.
Sink weight: 180 kg approx.*

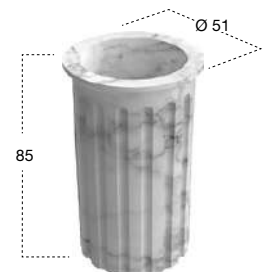



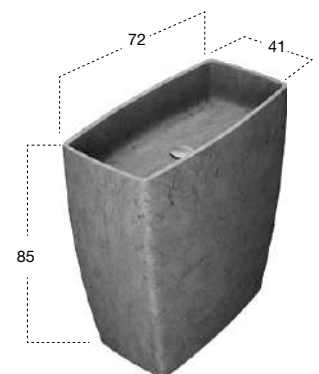

lavabi / sinks
freestanding

	H	P	L	art.
Pietra Stone Grey	85	41	72	TENDERSG

Lavabo da terra in pietra con scarico a pavimento, completo di piletta con scarico libero, sifone e tubo flessibile.

Peso lavabo: 300 kg ca.

*Freestanding stone sink with floor drainage complete with open plug, siphon and flexible hose.
Sink weight: 300 kg approx.*





lavabi / sinks
freestanding

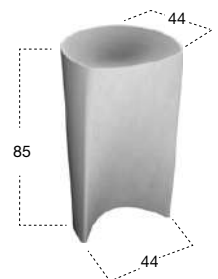

	H	P	L	art.
Pietra Amazzone	85	44	44	RILIEVO

Lavabo da terra in pietra con scarico a pavimento, completo di piletta con scarico libero, sifone e tubo flessibile.

Peso lavabo: 170 kg ca.

*Freestanding stone sink with floor drainage complete with open plug, siphon and flexible hose.
Sink weight: 170 kg approx.*





lavabi / sinks
freestanding

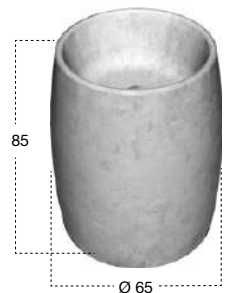

	H	Ø	art.
Pietra Sinai / Nero Marquina	85	65	BARREL

Lavabo da terra in pietra con scarico a pavimento, completo di piletta con scarico libero, sifone e tubo flessibile.

Peso lavabo: 320 kg ca.

*Freestanding stone sink with floor drainage complete with open plug, siphon and flexible hose.
Sink weight: 320 kg approx.*





DIERESI design Carlo Colombo

Scultoreo nella sua asimmetria pronunciata, dinamico grazie alla continuità tra base e bacino che si sviluppano secondo tracce diagonali, iconico nel suo “chiudersi” per poi “riaprirsi”. La base si stringe salendo verso l’alto, il bacino si allarga dalla dimensione minima in cui la incontra fino alla sommità. Il gioco di pieni e vuoti, di proporzioni inedite genera una sensazione di disequilibrio che è propria degli elementi naturali, cresciuti senza che l’uomo ne abbia in qualche modo definito regole precise e moduli da rispettare. Dieresi addolcisce i tratti diagonali con le linee morbide degli spigoli, con la continuità dei raccordi tra le linee convergenti, concentra le forze nel punto di contatto fra i due volumi principali e le fa esplodere allargandosi per accogliere l’acqua.

Sculptural in its pronounced asymmetry, dynamic thanks to the continuity between the base and the basin that develop along diagonal tracks, iconic when it “closes” and then “re-opens”
The base narrows going up to the top, the basin broadens. The solids and voids, of unprecedented proportions generates a feeling of imbalance which is characteristic of the natural elements. Dieresis sweetens the diagonal strokes with the soft lines of the edges, with the continuity of the connections between the converging lines, it focuses the forces at the contact point between the two main volumes and detonates, widening to accommodate the water.

	H	P	L	art.
Marmo di Carrara	85	60	60	DIERESI

Lavabo da terra in pietra con scarico a pavimento, completo di piletta con scarico libero, sifone e tubo flessibile.

Peso lavabo: 190 kg ca.

Freestanding stone sink with floor drainage complete with open plug, siphon and flexible hose. Sink weight: 190 kg approx.







PIPA design Carlo Colombo

Volumi importanti, perfetta continuità delle forme che rimandano a quelle di una pipa per la contrapposizione di un blocco importante orizzontale innestato su un fusto verticale. Un monolite dalla forma irregolare, un lavabo asimmetrico che sembra sfidare la forza di gravità con uno sbalzo molto pronunciato che si lancia nel vuoto. Un bacino capiente che completa un corpo identificato da un taglio diagonale che si raccorda perfettamente alla "mensola" orizzontale in una continuità dinamica che sembra lascia sfogare la forza sprigionata dal blocco di pietra. Una "L rovesciata" solida e preziosa, una figura in cui le linee convergono alternando superfici perfettamente piane e nette ad altre altrettanto curve e continue.

Important volumes, perfect continuity of forms that refer to those of a pipe for the juxtaposition of a horizontal block engaged on a vertical stem.

A monolith with an irregular shape, an asymmetrical washbasin that seems to defy gravity with a very pronounced overhang that launches into space. A large basin that completes a body identified by a diagonal cut that is connected perfectly to the "horizontal shelf" in a dynamic continuity that seems to vent unleashed by the block of stone. An "inverted L" solid and valuable, a figure in which the lines converge alternating perfectly flat and net areas to other equally curved and continuous.

	H	P	L	art.
Marmo di Carrara / Pietra Stone Grey / Nero Marquina	85	46	72	PIPA

Lavabo da terra in pietra con scarico a pavimento, completo di piletta con scarico libero, sifone e tubo flessibile.

Peso lavabo: 233 kg ca.

Freestanding stone sink with floor drainage complete with open plug, siphon and flexible hose. Sink weight: 233 kg approx.

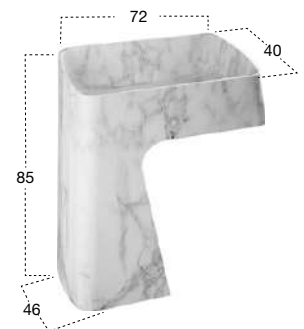

lavabi / sinks
freestanding





lavabi / sinks
freestanding



	H	Ø	art.
Pietra Vesuvio	85	65	PILA16

Lavabo da terra in pietra con scarico a pavimento, completo di piletta con scarico libero, sifone e tubo flessibile.
Peso lavabo: 240 kg ca.

*Freestanding stone sink with floor drainage complete with open plug, siphon and flexible hose.
Sink weight: 240 kg approx.*





lavabi / sinks
freestanding

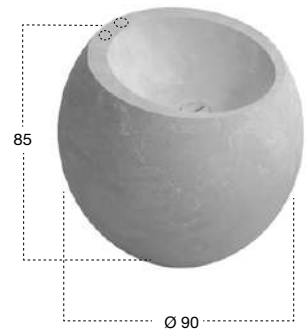

	H	Ø	art.
Pietra Luna	85	90	OPIUM

Lavabo da terra in pietra con scarico a pavimento, completo di piletta con scarico libero, sifone e tubo flessibile.

Peso lavabo: 780 kg ca.

N.B. Per l'ispezione, si consiglia di realizzare un pozzetto esterno (vedere schede tecniche).

*Freestanding stone sink complete with drain pipe fitting and open plug, trap and flexible hose.
Sink weight: 780 kg approx.*

P.S. We advise an exterior inspection window (see technical drawings).

ECLIPSE design Marco Di Paolo

Elegante e funzionale, dalla forte presenza scenica ma allo stesso tempo capace di inserirsi in contesti diversi: Eclipse è una vasca avvolgente dalla forma a uovo che accoglie e protegge ergonomicamente il corpo.

La continuità delle linee e delle superfici resa possibile dall'utilizzo del Cristalplant descrive un volume organico e capiente che può occupare con personalità il centro della stanza ma anche accostarsi a una parete secondo una disposizione personalizzata, non avendo in sé alcuna gerarchia dei fronti come nell'essenza del "tutto tondo".

Ad accrescere la funzionalità della vasca è stata sviluppata una piccola mensola portaoggetti, integrata nel volume con armonia e misura.

Una traccia che ingentilisce il bordo e diventa un segno distintivo di raffinatezza, un dettaglio prezioso che sottolinea la forma senza rimanere fine a sé stesso ma al contrario diventa pratica base da appoggio per ospitare tutti gli accessori in un relax davvero completo.

Elegant and functional, with strong stage presence but at the same time able to fit in different contexts: Eclipse is an enveloping egg-shaped tub that welcomes and ergonomically protects the body.

The continuity of the lines and surfaces made possible by the use of Cristalplant describes a large volume that can occupy the center of the room with personality but also be placed in a personalized arrangement.

To increase the functionality of the bathtub, a small storage shelf has been developed and integrated into its volume with harmony and measure.

A trace that softens the edge and becomes a distinctive sign of refinement, a precious detail that emphasizes the shape and becomes a practical shelf to accommodate all the accessories for a truly complete relaxation.



VASCHE / TUBS



ECLIPSE







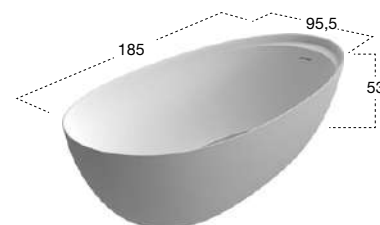

H	P	L	art.
53	95,5	185	ECLIPSE

Vasca da bagno ovale in Cristalplant, completa di piletta con sistema di scarico a pressione klik clak, sifone e tubo flessibile.

Peso vasca: 134 kg.

Capacità: 350 L.

Oval Cristalplant bathtub complete with drain and pressure plug, siphon and flexible hose.

Weight: 134 kg.

Capacity: 350 L.

DAFNE design Daniel Debiasi e Federico Sandri

Una forma naturale, sobria ma allo stesso tempo organica, un progetto che attraverso piccole variazioni sul tema esprime un perfetto connubio tra estetica e funzionalità. Una vasca elegante, dall'immagine leggera, rassicurante e dalla forma compatta, che gioca su un delicato equilibrio dimensionale per dar vita a un elemento confortevole e accattivante: Dafne trova nel bordo che si alza leggermente in corrispondenza di uno dei lati uno dei tratti distintivi del progetto, non solo dal punto di vista formale ma anche un sotto l'aspetto funzionale perchè aumenta il comfort complessivo. Il bordo sollevato accoglie infatti comodamente le spalle, mentre le linee curve del bacino che si sviluppano senza soluzione di continuità invitano ad immergersi per piacevoli momenti di relax.

Natural form, sober yet organic, a project that through small variations expresses a perfect combination of aesthetics and functionality. An elegant bathtub seemingly light and compact in size that plays upon a delicate dimensional balance to give life to a comfortable and attractive element: one side slightly raised is the hallmark of the project increasing the overall comfort. This raised part accommodates the shoulders while the curved lines of the bottom invite you to immerse in wonderful moments of relaxation.







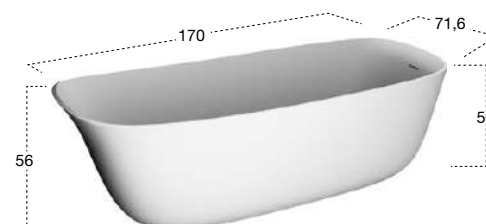

H	P	L	art.
56	71,6	170	DAFNE

Vasca da bagno ovale in Cristalplant, completa di piletta con sistema di scarico a pressione klik clak, sifone e tubo flessibile.

Peso vasca: 110 kg.

Capacità: 275 L.

Oval Cristalplant bathtub complete with drain and pressure plug, siphon and flexible hose.

Weight: 110 kg.

Capacity: 275 L.

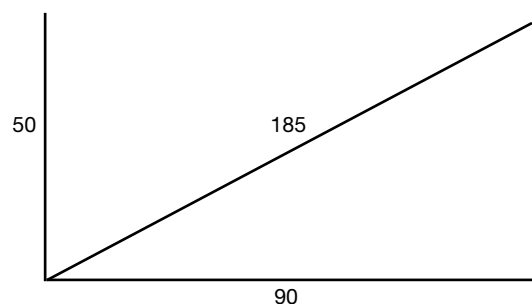

Essenziale ma con una forte personalità, pura nelle forme ma organica nel suo sviluppo complessivo, moderna pur nell'impronta classica, continua nell'assoluta assenza di spigoli. Un masterpiece di antoniolupi, un progetto che ha segnato un'inizio, anzi l'inizio del modo nuovo di concepire l'oggetto vasca. Prodotto per la prima volta nel 2004 Baia è ancor oggi una delle assolute protagoniste della gamma e uno dei modelli più venduti. Design pulito ed elegante, armonia e minimalismo accentuati dall'impiego del Cristalplant o arricchiti da sfumature uniche e tracce irripetibili qualora venga realizzata in pietra. Gli spessori sottilissimi garantiti dall'impiego del solid surface, aumentano considerevolmente quando viene impiegato il materiale naturale. L'eterea presenza e il candore di Baia, nella versione "artificiale" lasciano spazio alla solidità e al lusso concreto della versione in pietra. La base di dimensioni ridotte garantisce leggerezza alla composizione e interrompe la continuità del volume per sottolineare l'importanza della matrice generativa.

Basic but with a strong personality pure in form but organic in its overall development. Modern yet classic with an absolute absence of sharp edges. A masterpiece by antoniolupi, a project that has marked a beginning, indeed that of a new way of conceiving the bathtub. Introduced in 2004, Baia, is still today one of the absolute protagonists of the range and one of the best selling models. Clean and elegant design harmony and minimalism marked by the use of Cristalplant or enriched by unique shades and unrepeatable trace when made of stone. Thin borders guaranteed by the use of solid surface significantly increase with natural stone. The ethereal presence and the candor of Baia in the artificial version give way to solid and concrete luxury of stone. The smaller version guarantees lightness to the composition and breaks the continuity of the volume.

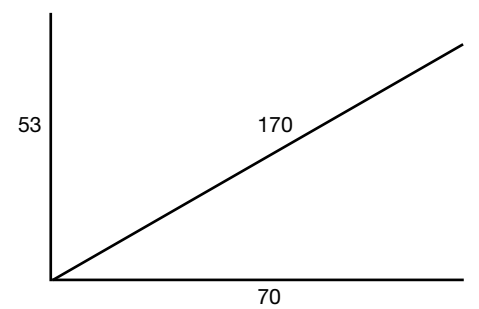

vasche / tubs





Verniciabile esternamente in tutti i colori del nostro campionario
Can be externally lacquered in all colors of our collection

H	P	L	art.
50	90	185	BAIA

Vasca da bagno ovale in Cristalplant, completa di piletta con sistema di scarico a pressione clik-clak, sifone e tubo flessibile.

Peso vasca: 90 kg.

Capacità: 400 L.

Oval Cristalplant bathtub complete with drain pipe fitting and pressure plug, siphon and flexible hose.

Weight: 90 kg.

Capacity: 400 L.







Verniciabile esternamente in tutti i colori del nostro campionario
Can be externally lacquered in all colors of our collection

H	P	L	art.
53	70	170	BAIAS

Vasca da bagno ovale in Cristalplant, completa di piletta con sistema di scarico a pressione clik-clak, sifone e tubo flessibile.

Peso vasca: 78 kg.

Capacità: 247 L.

Oval Cristalplant bathtub complete with drain pipe fitting and pressure plug, siphon and flexible hose.

Weight: 78 kg.

Capacity: 247 L.



EDONIA design Mario Ferrarini

Una forma inedita, una base rettangolare che viene plasmata e "stirata" per modificarne la percezione e rendere meno statica la composizione. Una vasca senza tempo, comoda, elegante e pratica. Si parte da un blocco rettangolare, se ne addolciscono le linee, gli angoli, i bordi. Si curvano leggermente i lati, sia quelli lunghi che i due corti. Si alleggerisce l'immagine complessiva rialzando la vasca su quattro zampe angolari che la tengono sollevata da terra e generano negli spigoli un effetto "vela" che contribuisce ad accentuare la sensazione di leggerezza e dinamicità.

An unusual shape, rectangular at its base, shaped and stretched to change its perception seemingly timeless, comfortable, elegant and practical.

Starting from a rectangular block the lines, corners and edges are softened. It has slightly curved sides. The overall effect is very light and raised off the ground on four corner legs.

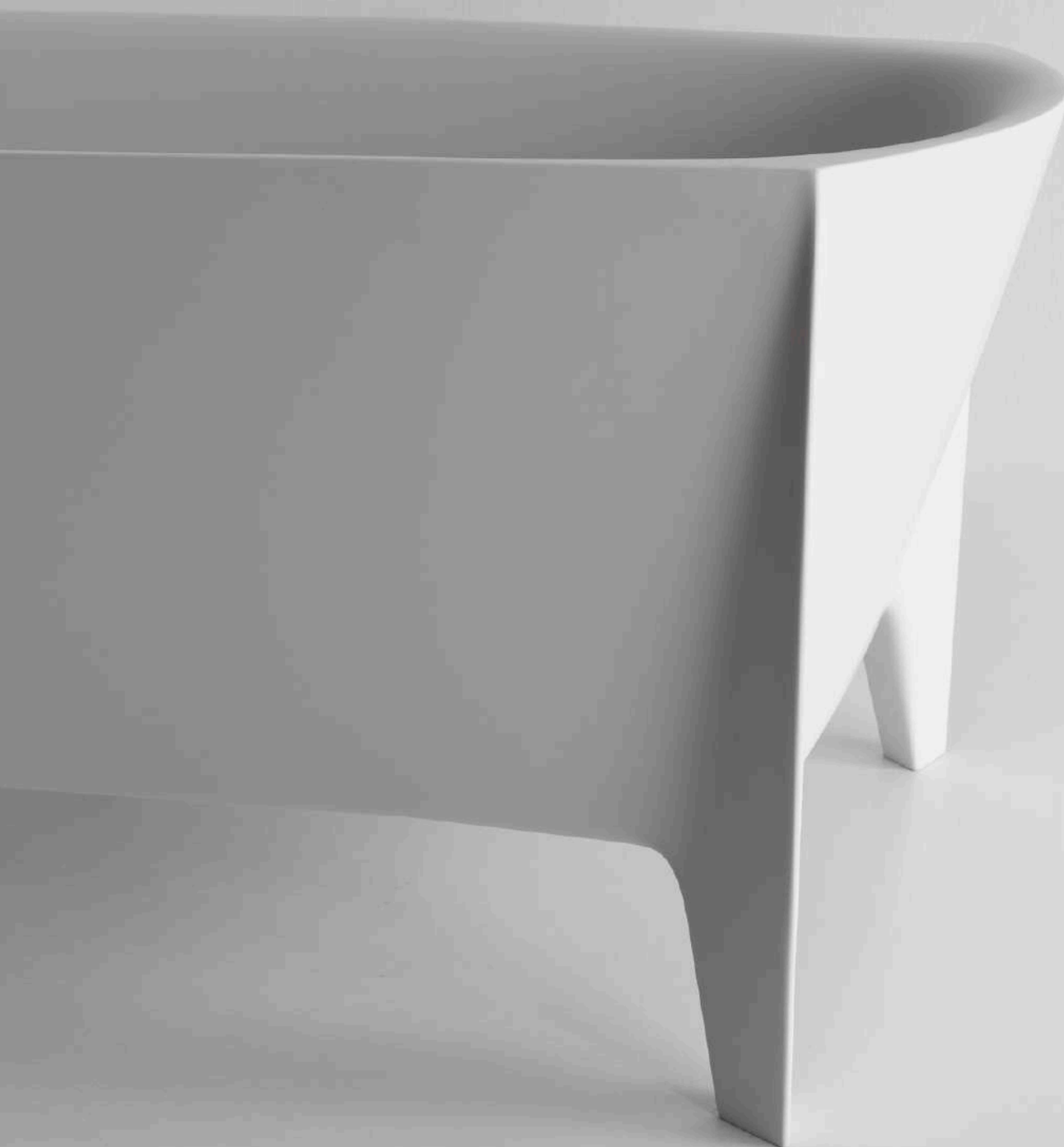







Verniciabile esternamente in tutti i colori del nostro campionario
Can be externally lacquered in all colors of our collection



H	P	L	art.
60	76	172	EDONIA

Vasca da bagno rettangolare in Cristalplant con piedini, completa di piletta con sistema di scarico a pressione klik- clak, sifone e tubo flessibile.

Peso vasca: 125 kg.

Capacità: 272 L.

Rectangular Cristalplant bathtub with feet, complete with drain with pressure plug, siphon and flexible tube.

Weight: 125 kg.

Capacity: 272 L.

AGO design Mario Ferrarini

Un'immagine contemporanea nata dall'equilibrata fusione di geometrie, linee curve e rette; un bordo sottile che identifica un perimetro e definisce un limite; una forma compiuta e avvolgente; vasca in Cristalplant dalla geometria ovale, perfetta sintesi tra parti curve ad ampio raggio e lati inclinati che dalla base salgono ad incontrare la parte curva.

A contemporary image created by the balanced fusion of geometrical shapes, curves and straight lines; a thin edge that identifies the perimeter and defines a limit; a complete and enveloping shape. A bathtub in Cristalplant with an oval shape, perfect synthesis between curves and sloping sides.







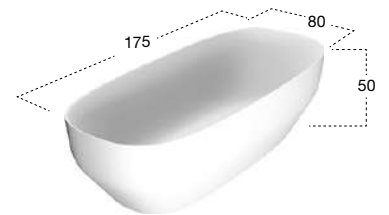

H	P	L	art.
50	80	175	AG04

Vasca da bagno ovale in Cristalplant, completa di piletta con sistema di scarico a pressione clik-clak, sifone e tubo flessibile.
 Peso vasca: 97,5 kg.
 Capacità: 345 L.

*Oval Cristalplant bathtub complete with drain and pressure plug, siphon and flexible hose.
 Weight: 97,5 kg.
 Capacity: 345 L.*



FUNNY WEST design Paolo Cappello e Federico Sandri

Un'onda appena annunciata, un bordo che cresce in altezza e si trasforma da elemento contenitivo in schienale senza soluzione di continuità. Funny West trasmette un'immagine un pò scanzonata, uno stile informale ma elegante allo stesso tempo, un profilo a metà tra un fenomeno naturale e la scocca di un bolide che percorre le highway correndo verso la West Coast. Una piccola ma grande vasca, lunga solo 151 cm ma in grado di ospitare comodamente due persone grazie a un progetto attento alle proporzioni e all'ergonomia, caratteri imprescindibili di tutti i prodotti antoniolupi.

A wave just reported, an edge that increases in height and is transformed from a restraining element in the backrest without solution of continuity. Funny West transmits an image a little carefree, casual yet elegant somewhere between a natural phenomenon and the body of a fireball that travels the highway running to the West Coast.

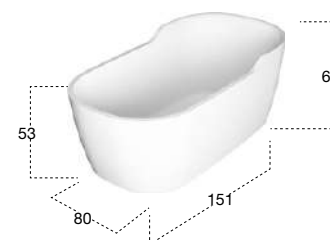

H	P	L	art.
60	80	151	FUNNY WEST

Vasca da bagno ovale con schienale in Cristalplant, completa di piletta con sistema di scarico a pressione klik-clak sifone e tubo flessibile.

Peso vasca: 95 kg.

Capacità: 292 L.

Oval Cristalplant bathtub with back rest complete with drain and pressure plug, siphon and flexible hose.

Weight: 95 kg.

Capacity: 292 L.



WANDA design Daniel Debiassi e Federico Sandri

I bordi sinuosi si alzano asimmetricamente su uno dei lati, quello naturalmente predisposto ad appoggiarvi la schiena. Le linee fluide accompagnano questa crescita assecondando il gesto del corpo che si immerge nella vasca. Dall'altra parte l'altezza rimane invariata a testimoniare lo sviluppo longitudinale della parte che ospita le gambe. Wanda esprime fin da subito la scansione gerarchica del progetto, con una scelta immediata e di facile lettura in merito al suo utilizzo. Ne rimane un oggetto scultoreo ed ergonomico, una vasca dall'immagine sinuosa, femminile, accattivante.

The edges rise symmetrically on one side to naturally lean back upon. The flowing lines accompany this growth favoring the gesture of the body immersed in the bath. Wanda expresses the perfect Antoniolupi concept. It remains a sculpture, an ergonomic object, a winding bath, feminine and attractive.







H	P	L	art.
77,2	84	178	WANDA

Vasca da bagno ovale in Ceramilux con schienale, completa di piletta con sistema di scarico a pressione klik-clak, sifone e tubo flessibile.

Peso vasca: 120 kg.

Capacità: 384 L.

Oval Ceramilux bathtub with back rest complete with drain and pressure plug, siphon and flexible hose.

Weight: 120 kg.

Capacity: 384 L.



SOLIDEA design Carlo Colombo

Nasce da una deformazione della materia. Parte da una forma, da una geometria, per assumerne un'altra. Trasformista, ibrida e per questo contemporanea, interprete di una materia mutevole, che si plasma per esprimere dinamismo. Si parte da una base rettangolare, dagli spigoli arrotondati; poi le pareti si deformano progressivamente e lentamente fino a raggiungere l'ovale del bordo della vasca. La materia si tende come fosse un telo elastico, le forze disegnano una nuova forma irregolare, ma fatta di armonia e nuovi equilibri proporzionali. Solidea è realizzata in Cristalplant o marmo ed esprime tutta la ricerca plastica di antoniolupi che si traduce in forme inedite ed evolute.

This bathtub comes from a deformation of the material. It starts as one shape to finish in another. Transformer, hybrid and for this modern. Interpreter of a changeable matter molded to express dynamism. Beginning from a rectangular base with rounded edges, the walls deform gradually and slowly to reach the oval border of the bathtub. Matter stretches like an elastic cloth, forces design a new irregular shape yet harmonious and proportionally balanced. Solidea is made of Cristalplant or marble and expresses all the research by antoniolupi resulting in new and evolved forms.



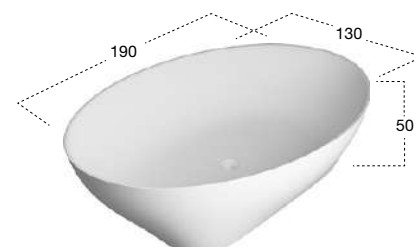

H	P	L	art.
50	130	190	SOLIDEA1

Vasca da bagno ovale in Cristalplant, completa di piletta con sistema di scarico a pressione clik-clak, sifone e tubo flessibile.

Peso vasca: 141 kg.

Capacità: 500 L.

Oval Cristalplant bathtub complete with drain pipe fitting and pressure plug, siphon and flexible hose.

Weight: 141 kg.

Capacity: 500 L.

DUNE design Mario Ferrarini

Organica nella forma, naturale nello sviluppo delle linee, morbida e accogliente nel suo segno distintivo. Un'oasi di benessere originata da una forma circolare e definita da un bordo sinusoidale.

La metafora della natura guida il progetto Dune, declinato in una vasca dall'immagine morbida che custodisce un bene prezioso in un perimetro mosso e articolato. Accogliente e priva di discontinuità, non presenta un fronte privilegiato e può assumere configurazioni diverse sia nella versione free standing che in quella a semi incasso. Le continue variazioni di altezza del bordo è il tratto distintivo di una proposta di carattere ma allo stesso tempo versatile e flessibile.

Organic in shape natural development of lines, soft and cozy in its hallmark. An oasis of well-being originated from a circular shape and defined by a sinusoidal edge. Welcoming and free of discontinuities, it doesn't have a privileged side and can assume different configurations both in the freestanding version as the semi-recessed one. The continuous variation in height of the edge is the hallmark of a proposal of character but at the same time flexible and versatile.



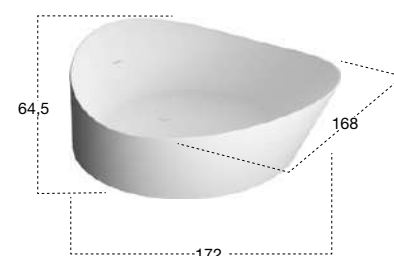

H	P	L	art.
64,5	168	172	DUNE1

Vasca da bagno tonda in Cristalplant, completa di piletta con sistema di scarico a pressione clik-clak, sifone e tubo flessibile.

Peso vasca: 191 kg.

Capacità: 430 L.

Round Cristalplant bathtub complete with drain pipe fitting and pressure plug, siphon and flexible hose.

Weight: 191 kg.

Capacity: 430 L.



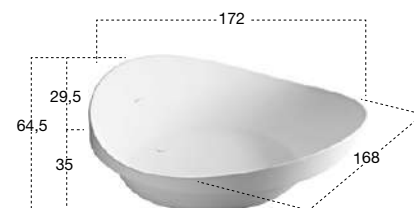
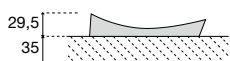

H	P	L	art.
64,5	168	172	DUNE2

Vasca da bagno tonda a semincasso in Cristalplant, completa di piletta con sistema di scarico a pressione klik-clak, sifone e tubo flessibile.

Peso vasca: 142 kg.

Capacità: 430 L.

Semi-encased round Cristalplant bathtub complete with drain pipe fitting and pressure plug, siphon and flexible hose.

Weight: 142 kg.

Capacity: 430 L.





SUITE design Roberto Lazzeroni

Effetto retrò, immagine che rimanda ad atmosfere lontane nel tempo ma rivista in chiave contemporanea, con personalità, stile e capacità di inserirsi in ambienti bagno di gusto borghese.

Morbida, avvolgente, testimone di un passato che si inserisce nel presente con personalità e identità. Realizzata in Cristalplant, Suite è la vasca dalle linee sinuose che trova nell'ampio bordo ripiegato all'indietro uno dei tratti distintivi. Un dettaglio che diventa simbolo, un elemento estetico e funzionale che delimita il perimetro della vasca e invita ad entrare, un segno forte che ne completa l'originale presenza insieme all'inedita forme della scocca e alla presenza dei piedini che la tengono sospesa da terra. Un dettaglio classico rivisitato e riattualizzato.

Retro style, and image that remembers long ago but revised in a contemporary manner, with personality, style and ability to fit in the bathroom environments of a bourgeois taste.

Soft, enveloping, fitness of a past brought to the present with personality and identity. Made from Cristalplant, Suite is a bathtub with sinuous lines and large fold back as its main features. A detail that becomes a symbol, an aesthetic and functional element that defines the perimeter of the bathtub and invites you to enter. A strong sign that completes the presence of an original and new shell shape with legs. A classical revisited and refreshed idea.





Verniciabile esternamente in tutti i colori del nostro campionario
Can be externally lacquered in all colors of our collection

H	P	L	art.
78	90	192	SUITE248
78	90	192	SUITE310

Vasca da bagno ovale in Cristalplant con piedini, completa di piletta con sistema di scarico a pressione klik- clak, sifone e tubo flessibile.

Art. SUITE248

Peso vasca: 80 kg.

Capacità: 248 L.

Art. SUITE310

Peso vasca: 80 kg.

Capacità: 310 L.

Oval Cristalplant bathtub with feet, complete with drain with pressure plug, siphon and flexible tube.

Art. SUITE248

Weight: 80 kg.

Capacity: 248 L.

Art. SUITE310

Weight: 80 kg.

Capacity: 310 L.





SARTO design Carlo Colombo

Il trasformismo è il suo mestiere, la versatilità delle forme il modo di esprimersi, la capacità di interpretare qualsiasi esigenza progettuale la sua vera forza. Sartoriale, di nome e di fatto. Freestanding, totalmente o parzialmente incassata, rettangolare nel suo volume pulito o morbida nel suo inserirsi nello spazio, insomma capace di assumere forme e composizioni diverse per soddisfare qualsiasi esigenza del progetto, sia dal punto di vista stilistico, sia per quanto riguarda il suo inserimento dello spazio. La disposizione asimmetrica del bacino della vasca rispetto al volume complessivamente occupato determina di fatto una gerarchia dei fronti e dal punto di vista funzionale un bordo di dimensioni considerevoli che diventa pratico piano d'appoggio. Nella versione freestanding la possibilità di presentare l'intero blocco vasca o al contrario di lasciare il bacino nudo determina un aspetto scultoreo differente, quasi come se la forma fosse ottenuta per sottrazione modellando un blocco grezzo.

Transformation at its best, versatility of shape and expression, the ability to interpret any project requirement are a few strengths. Tailoring, in name and in fact. Freestanding, totally or partially recessed capable of assuming different shapes and compositions to meet all needs of the project. In the freestanding version, the opportunity of presenting the entire block as opposed to leaving the bowl bare determines a different sculptural appearance almost as if the shape was obtained by subtraction molding a rough block of material.

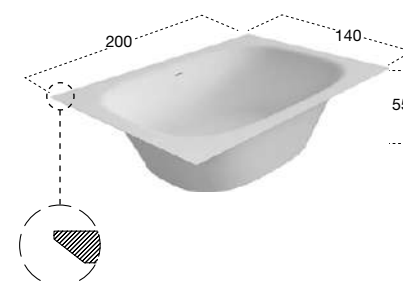

H	P	L	art.
55	140	200	SARTO MAXI2

Vasca da bagno rettangolare freestanding o da incasso in Cristalplant completa di piletta con scarico a pressione klik-clak, sifone e tubo flessibile.

Peso vasca: 157 kg.

Capacità: 511 L.

Rectangular Cristalplant freestanding or encased bathtub, complete with drain and pressure plug, siphon and flexible hose.

Weight: 157 kg.

Capacity: 511 L.





Verniciabile esternamente in tutti i colori del nostro campionario
Can be externally lacquered in all colors of our collection

H	P	L	art.
50	100	190	SARTO15

Vasca da bagno ovale freestanding o da incasso in Cristalplant, con bordo per rubinetteria sul retro completa di piletta con scarico a pressione klik-clak, sifone e tubo flessibile.

Peso vasca: 130 kg.

Capacità: 290 L.

Oval Cristalplant freestanding or encased bathtub with back rim for tap mounting, complete with drain and pressure plug, siphon and flexible hose.

Weight: 130 kg.

Capacity: 290 L.

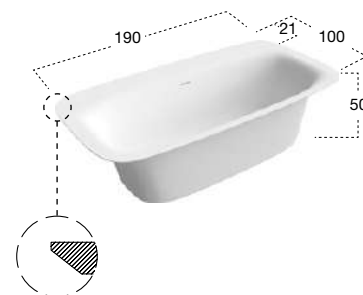

SARTO

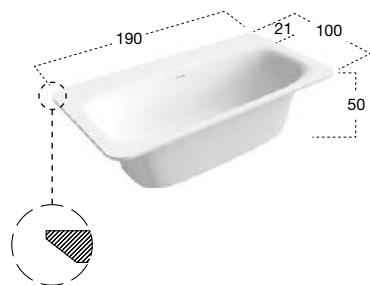

H	P	L	art.
50	100	190	SARTO14

Vasca da bagno rettangolare freestanding o da incasso in Cristalplant con bordo per rubinetteria sul retro e quattro angoli stondati, completa di piletta con scarico a pressione klik-clak, sifone e tubo flessibile.

Peso vasca: 136 kg.
Capacità: 290 L.

Rectangular Cristalplant freestanding or encased bathtub with back rim for tap mounting and 4 rounded corners, complete with drain and pressure plug, siphon and flexible hose.

*Weight: 136 kg.
Capacity: 290 L.*

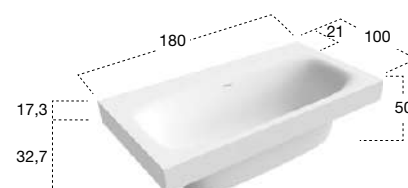
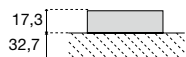

H	P	L	art.
50	100	180	SARTO36

Vasca da bagno rettangolare a semincasso in Cristalplant, con bordo per rubinetteria sul retro, completa di piletta con scarico a pressione klik-clak, sifone e tubo flessibile.

Peso vasca: 152 kg.

Capacità: 290 L.

Semi-encased rectangular Cristalplant bathtub with back rim for tap mounting, complete with drain and pressure plug, siphon and flexible hose.

Weight: 152 kg.

Capacity: 290 L.

SARTO

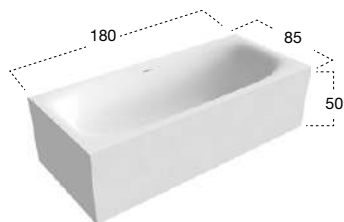
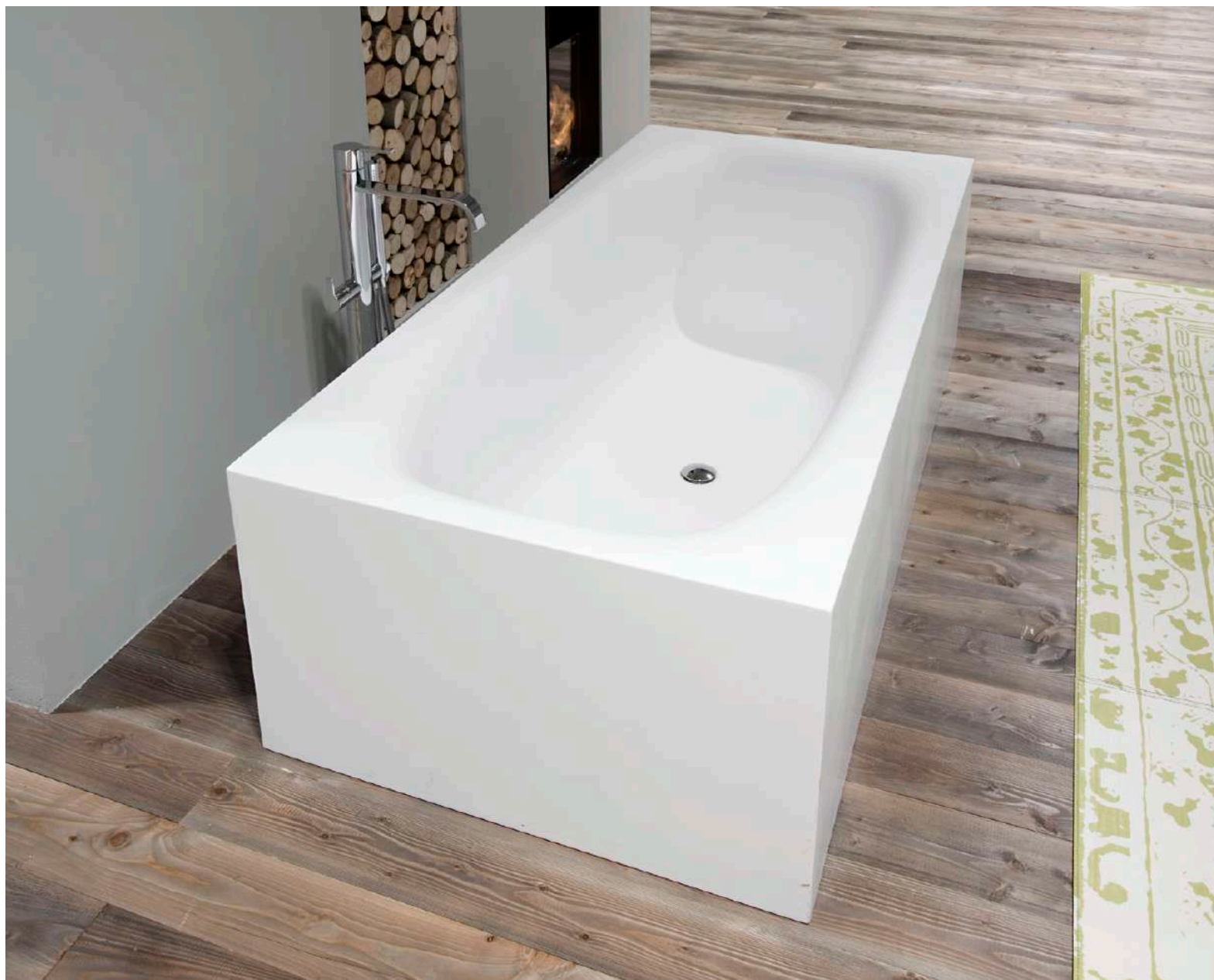

H	P	L	art.
50	85	180	SARTO47

Vasca da bagno rettangolare freestanding in Cristalplant completa di piletta con sistema di scarico a pressione clik-clak, sifone e tubo flessibile.

Peso vasca: 183 kg.

Capacità: 290 L.

Rectangular Cristalplant freestanding bathtub, complete with drain and pressure plug, siphon and flexible hose.

Weight: 183 kg.

Capacity: 290 L.

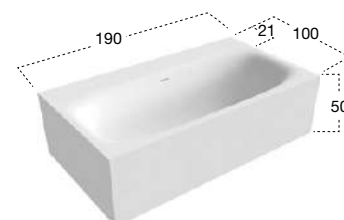

H	P	L	art.
50	100	190	SART017

Vasca da bagno rettangolare freestanding in Cristalplant, con bordo per rubinetteria sul retro, completa di piletta con scarico a pressione klik-clak, sifone e tubo flessibile.

Peso vasca: 203 kg.

Capacità: 290 L.

Rectangular Cristalplant freestanding bathtub with back rim for tap mounting, complete with drain and pressure plug, siphon and flexible hose.

Weight: 203 kg.

Capacity: 290 L.



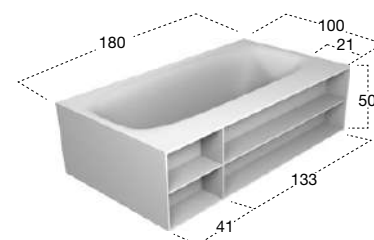

H	P	L	art.
50	100	180	SART053

Vasca da bagno rettangolare in Cristalplant, con vani a giorno frontali dx o sx e piletta con scarico a pressione clik-clak.

Peso vasca: 240 kg.

Capacità: 290 L.

Rectangular Cristalplant bathtub with front, right or left open compartments and pressure drain.

Weight: 240 kg.

Capacity: 290 L.



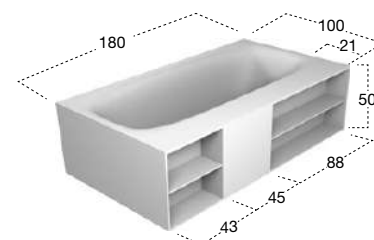
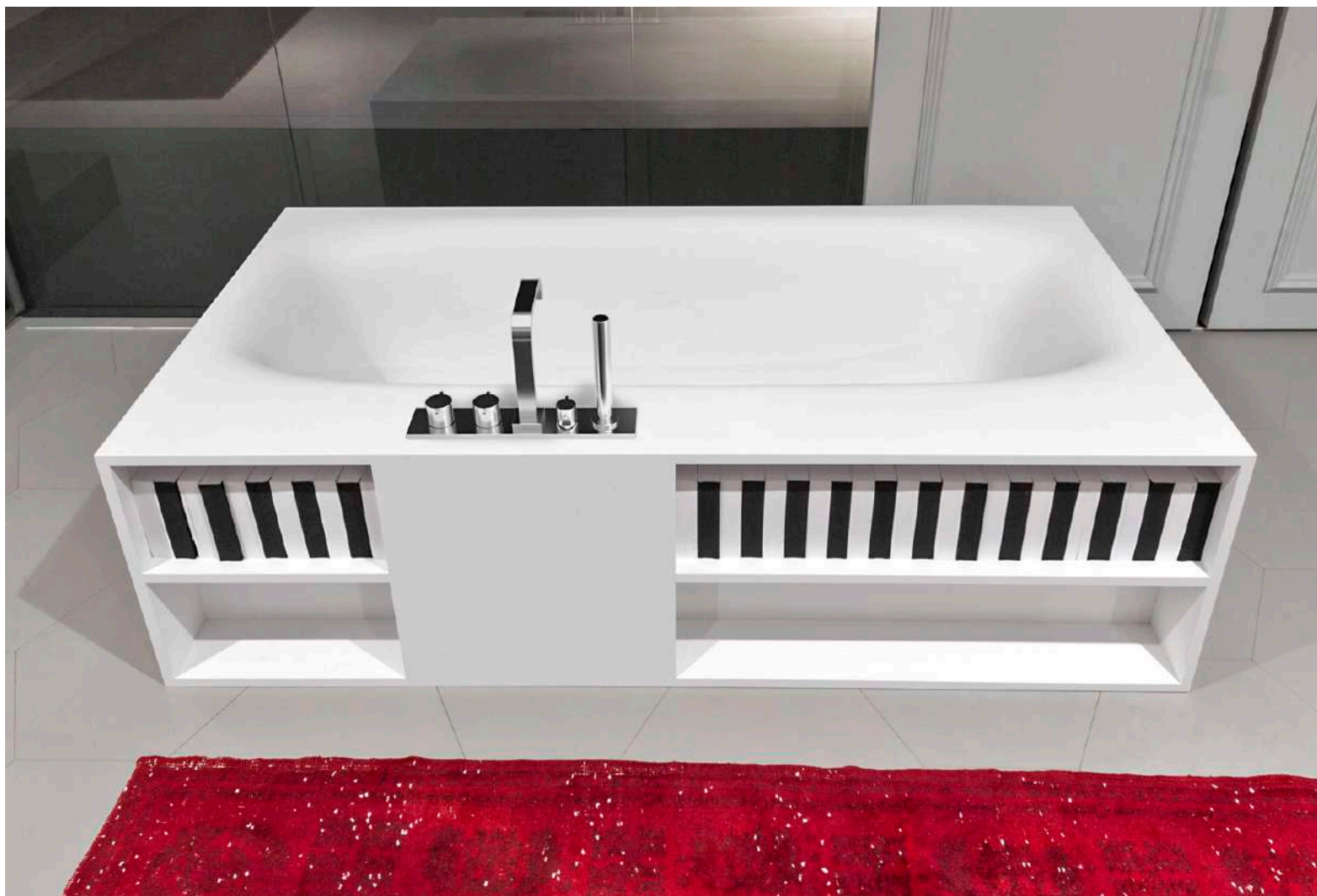

H	P	L	art.
50	100	180	SARTO153

Vasca da bagno rettangolare in Cristalplant con vani a giorno frontali, alloggio per rubinetteria dx o sx e piletta con scarico a pressione klik-clak.

Peso vasca: 260 kg.

Capacità: 290 L.

Rectangular Cristalplant bathtub with front open compartments, right or left tap border and pressure drain.

Weight: 260 kg.

Capacity: 290 L.

SARTORIALE

art. SART015



SART015 H 50 P 100 L 190

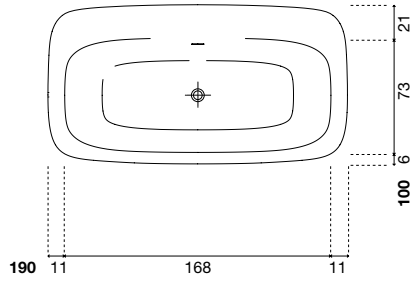

art. SART040/20



SART040 H 50 P 85 H L 180
SART020 H 50 P 85 H L 190

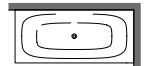
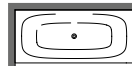
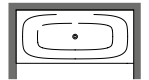
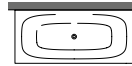
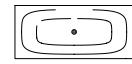
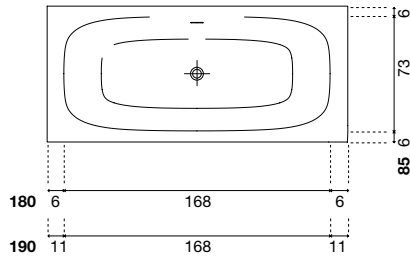

art. SART044/24



SART044 H 50 P 85 L 180
SART024 H 50 P 85 L 190

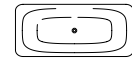
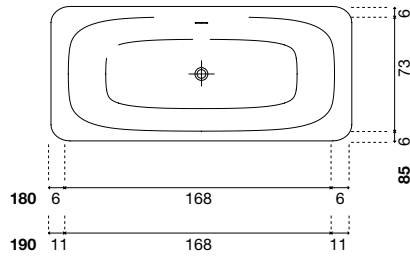

art. SART030/10



SART030 H 50 P 100 L 180
SART010 H 50 P 100 L 190

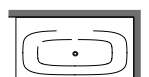
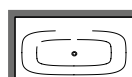
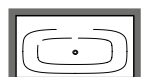
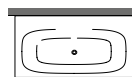
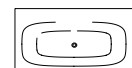
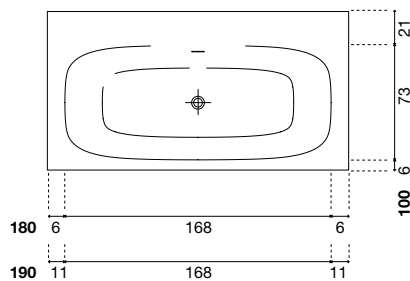

art. SART034/14



SART034 H 50 P 100 L 180
SART014 H 50 P 100 L 190

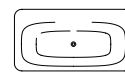
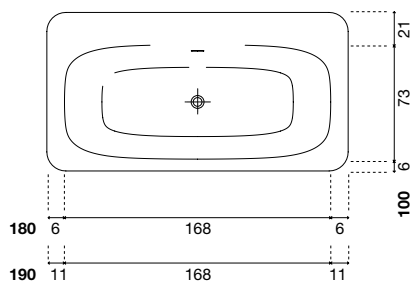

art. SART046



SART046 H 50 P 85 L 180

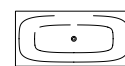
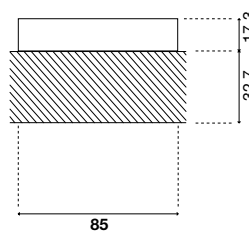
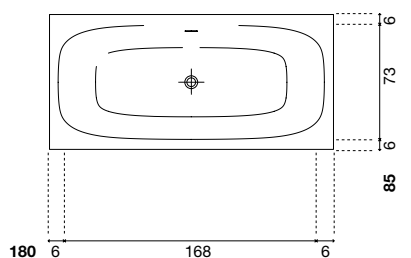

art. SART036



SART036 H 50 P 100 L 180

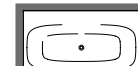
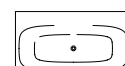
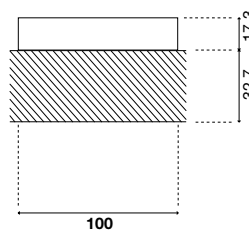
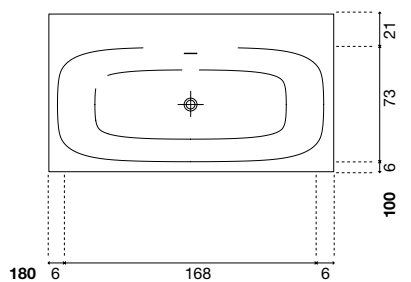

art. SART047/27



SART047 H 50 P 85 L 180
SART027 H 50 P 85 L 190

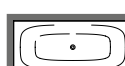
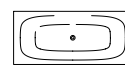
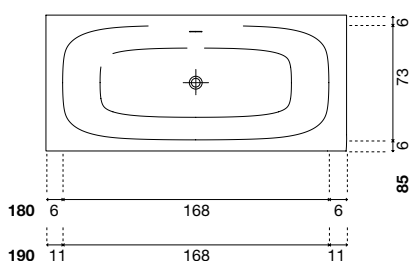

SARTORIALE

art. SARTO37/17



SARTO37 H 50 P 100 L 180
SARTO17 H 50 P 100 L 190

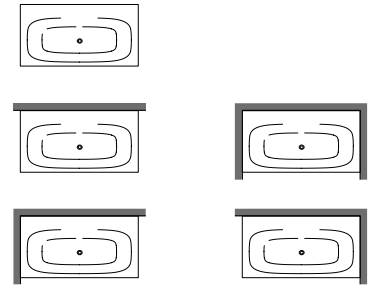
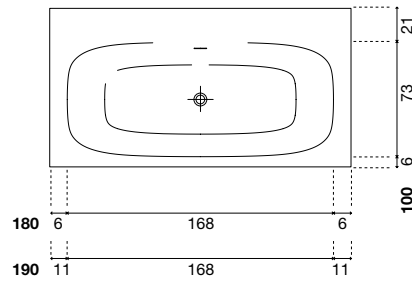

art. SARTO MAXI3



SARTO MAXI3 H 55 P 137 L 197

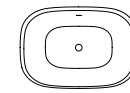
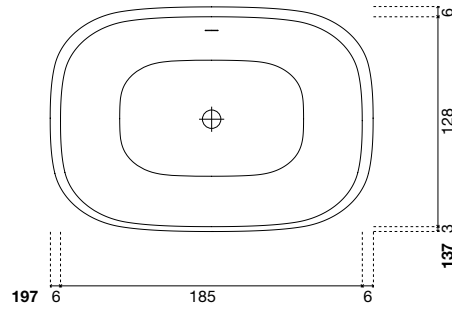

art. SARTO MAXI2



SARTO MAXI2 H 55 P 140 L 200

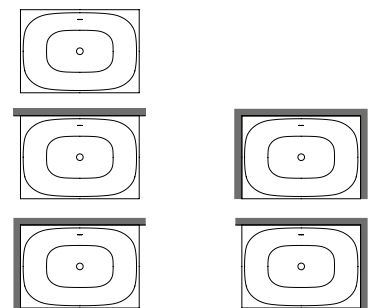
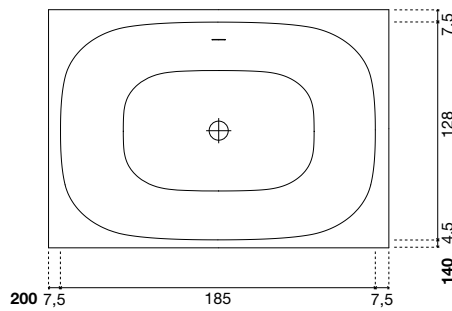

art. SARTO MAXI4



SARTO MAXI4 H 55 P 140 L 200

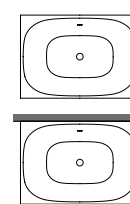
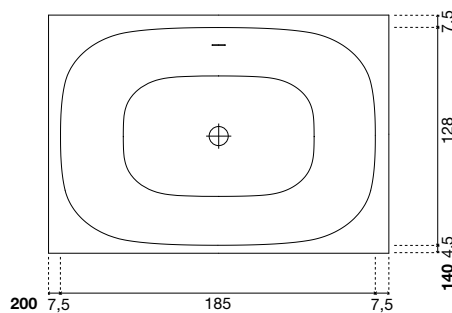

art. SART053

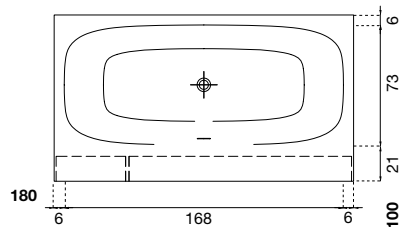

art. SART053 H 50 P 100 L 180

art. SART0153

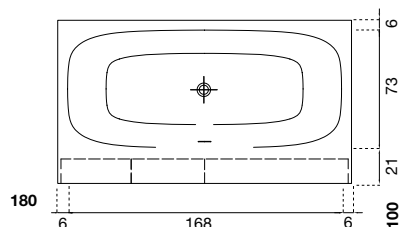

art. SART0153 L 180 P 100 H 50

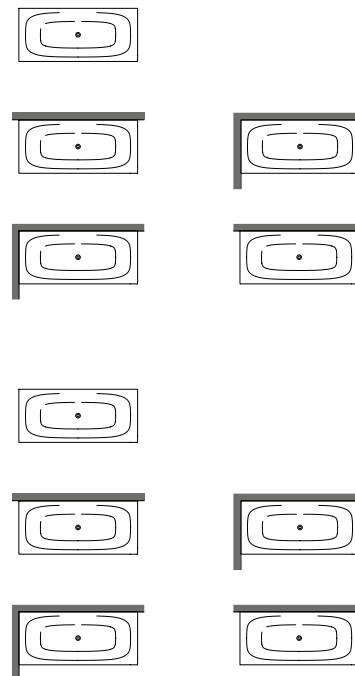

POSIZIONAMENTO RUBINETTERIA / TAP POSITION

Vista dall'alto e laterale del posizionamento del rubinetto sul bordo da 21 cm lato lungo vasca opzioni **A-B** degli Art. **BK701**, **AY701SA** e **AY701LU**.

Top and side view of tap position on border 21 cm. long side options **A-B** of Art. **BK701**, **AY701SA** and **AY701LU**.

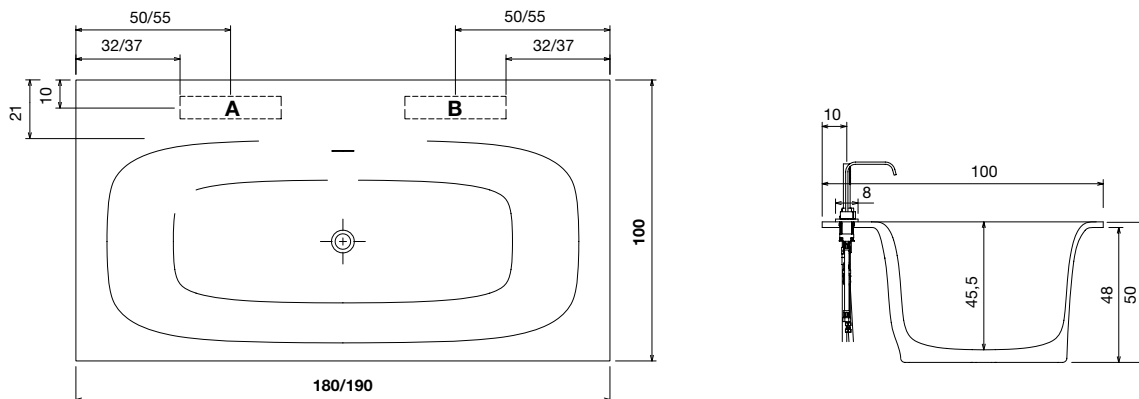

art. BK701

art. AY701SA
art. AY701LU

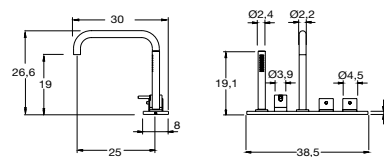
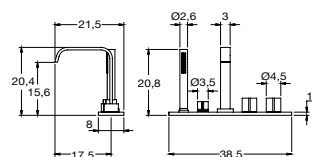

art. BK903N

art. AY903SA
art. AY903LU

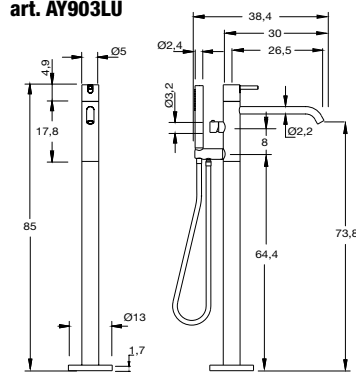
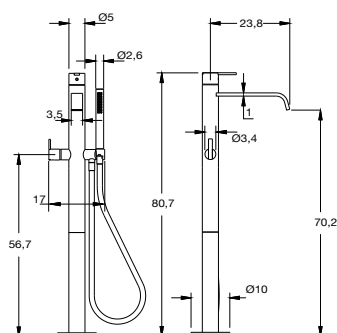

art. TB933

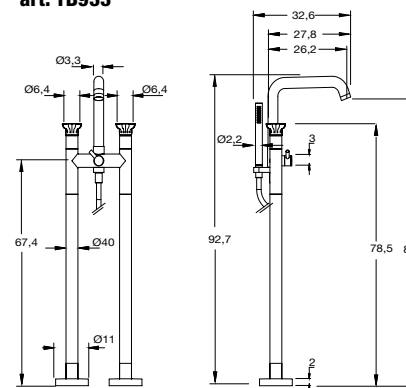

BIBLIO design Nevio Tellatin

Ampia, rigorosa nella sua geometria pura, negli spigoli vivi, nel linguaggio essenziale. Ricca, di nuovi significati, di spazi accessori, di superfici d'appoggio. Biblio è realizzata in Corian e può ospitare lungo due lati funzionali una serie di vani a giorno per riporre libri, oggetti e accessori. Spazi utili per organizzare lo spazio ma anche per personalizzare l'esperienza, volumi ricavati nel fianco che si allarga e diventa un pratico piano d'appoggio. Versatile perché può essere posizionata free standing o incassata, può integrare un piano rialzato a cui accedere con uno scalino. Democratica, perché può essere inoltre accostata a parte su qualsiasi lato, scegliendo il fronte tradizionale o quello nel quale sono ospitati i libri. Personalizzabile, perché la piccola libreria integrata può assumere un carattere diverso qualora venga rivestita con essenze o definita da colori particolari.

Large, rigorous in its pure shape with sharp corners. Rich with new meanings, space for accessories and surfaces. Biblio is made of Corian and can accommodate along two sides open compartments for books, objects and accessories. Useful spaces to organize and personalize your experience. Versatile because can be freestanding or embedded, democratic because approachable by either side. Customizable because the small built in library can take on a different character if covered with wood.





BIBLIO

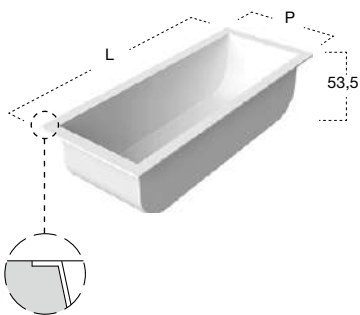

H	P	L	art.
53,5	70	170	BIBLI010
	80	180	BIBLI011

Vasca da bagno rettangolare da incasso in Corian, completa di piedini regolabili e piletta con scarico a pressione klik-clak.
 Art. BIBLI010
 Peso vasca: 81 kg.
 Capacità: 288 L.
 Art. BIBLI011
 Peso vasca: 82 kg.
 Capacità: 362 L.

*Encased rectangular Corian bathtub, complete with regulating feet and drain with pressure plug.
 Art. BIBLI010
 Weight: 81 kg.
 Capacity: 288 L.
 Art. BIBLI011
 Weight: 82 kg.
 Capacity: 362 L.*



H	P	L	art.
53,5	80	170	BIBLIO20
	90	180	BIBLIO21

Vasca da bagno rettangolare da incasso in Corian, con bordo per rubinetteria sul retro, completa di piedini regolabili e piletta con scarico a pressione clik-clak.

Art. BIBLIO20

Peso vasca: 75 kg.

Capacità: 288 L.

Art. BIBLIO21

Peso vasca: 90 kg.

Capacità: 362 L.

Encased rectangular Corian bathtub with back rim for tap mounting, complete with regulating feet and drain with pressure plug.

Art. BIBLIO20

Weight: 75 kg.

Capacity: 288 L.

Art. BIBLIO21

Weight: 90 kg.

Capacity: 362 L.

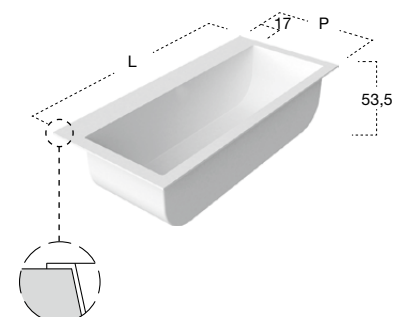

BIBLIO

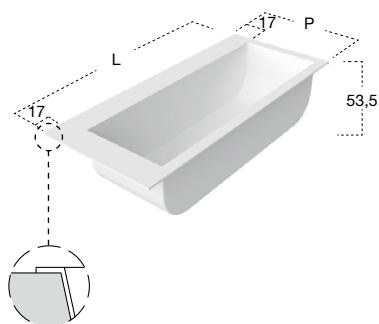

H	P	L	art.
53,5	80	180	BIBLI030
	90	190	BIBLI031

Vasca da bagno rettangolare da incasso in Corian, con bordo per rubinetteria sul retro e laterale dx o sx, completa di piedini regolabili e piletta con scarico a pressione klik-clak.

Art. BIBLI030

Peso vasca: 92 kg.

Capacità: 288 L.

Art. BIBLI031

Peso vasca: 95 kg.

Capacità: 362 L.

Encased rectangular Corian bathtub with back and right or left side rim for tap mounting, complete with regulating feet and drain with pressure plug.

Art. BIBLI030

Weight: 92 kg.

Capacity: 288 L.

Art. BIBLI031

Weight: 95 kg.

Capacity: 362 L.

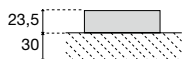

	H	P	L	art.
	53,5	80	180	BIBLIO80
		90	190	BIBLIO81

Vasca da bagno rettangolare da incasso in Corian, completa di piedini regolabili e piletta con scarico a pressione clik-clak.

Art. BIBLIO80

Peso vasca: 105 kg.

Capacità: 288 L.

Art. BIBLIO81

Peso vasca: 121 kg.

Capacità: 362 L.

Encased rectangular Corian bathtub, complete with regulating feet and drain with pressure plug.

Art. BIBLIO80

Weight: 105 kg.

Capacity: 288 L.

Art. BIBLIO81

Weight: 121 kg.

Capacity: 362 L.

art. BRIDGE

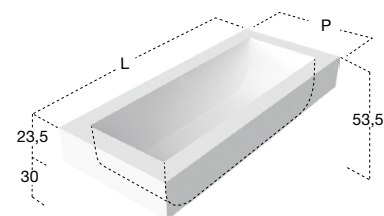

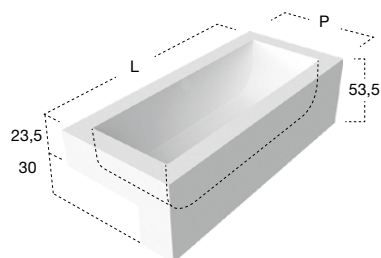
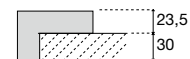

art. BRIDGE

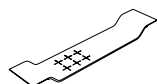

H	P	L	art.
53,5	80	180	BIBLI070
	90	190	BIBLI071

Vasca da bagno rettangolare da semincasso frontale in Corian, completa di piedini regolabili e piletta con scarico a pressione klik-clak.
 Art. BIBLI070
 Peso vasca: 118 kg.
 Capacità: 288 L.
 Art. BIBLI071
 Peso vasca: 131 kg.
 Capacità: 362 L.

*Semi-encased rectangular Corian bathtub complete with regulating feet and drain with pressure plug.
 Art. BIBLI070
 Weight: 118 kg.
 Capacity: 288 L.
 Art. BIBLI071
 Weight: 131 kg.
 Capacity: 362 L.*

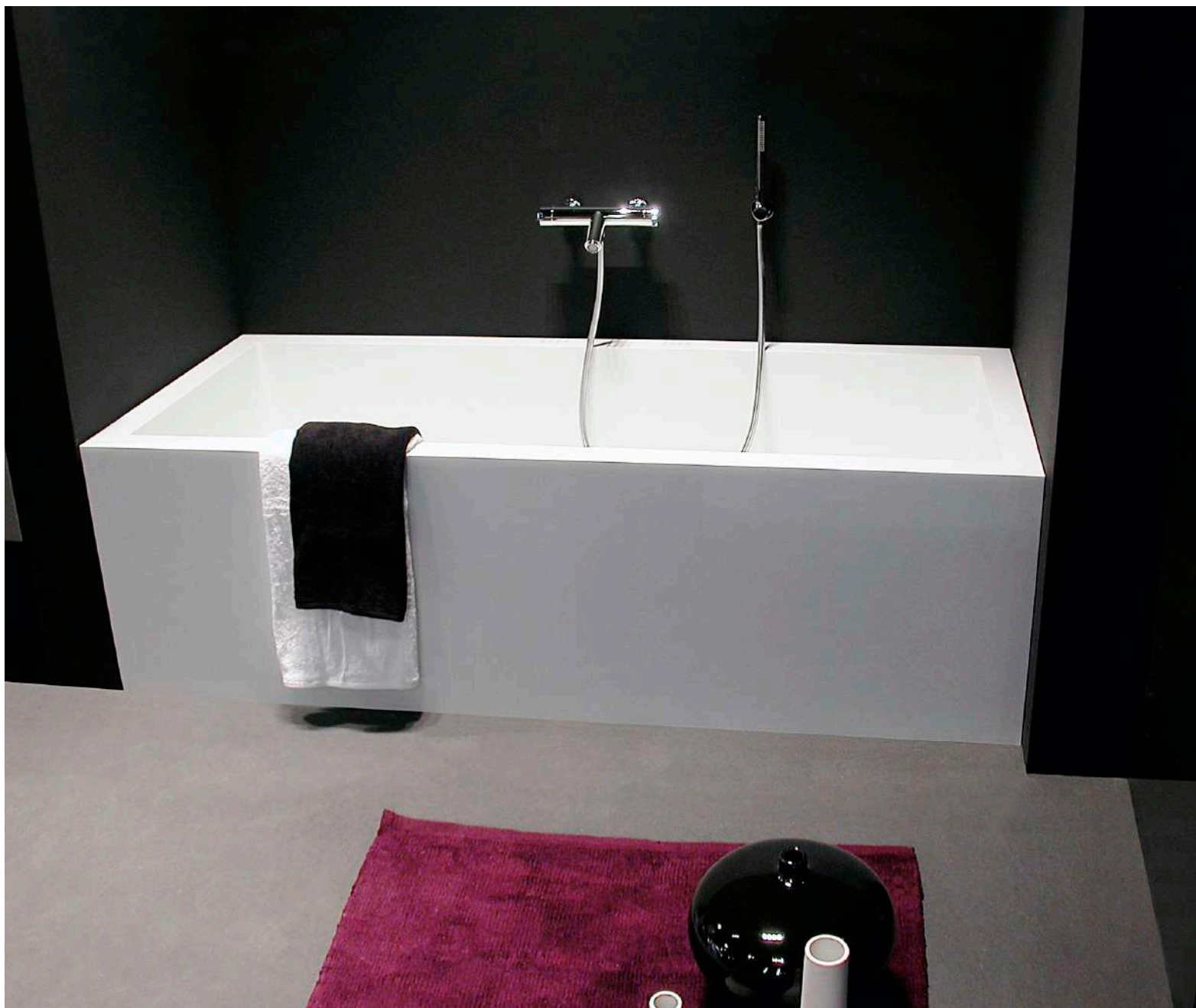

H	P	L	art.
53,5	70	170	BIBLIO12
	80	180	BIBLIO13

Vasca da bagno rettangolare in Corian, completa di piedini regolabili e piletta con scarico a pressione klik-clak.

Art. BIBLIO12

Peso vasca: 101 kg.

Capacità: 288 L.

Art. BIBLIO13

Peso vasca: 142 kg.

Capacità: 362 L.

Rectangular Corian bathtub, complete with regulating feet and drain with pressure plug.

Art. BIBLIO12

Weight: 101 kg.

Capacity: 288 L.

Art. BIBLIO13

Weight: 142 kg.

Capacity: 362 L.

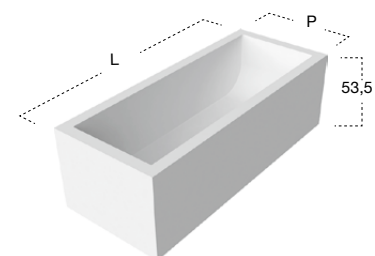

BIBLIO

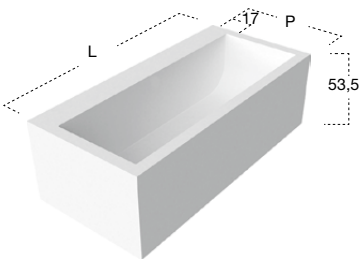

art. BRIDGE

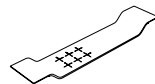

H	P	L	art.
53,5	80	170	BIBLIO22
	90	180	BIBLIO23

Vasca da bagno rettangolare in Corian, con bordo per rubinetteria sul retro, completa di piedini regolabili e piletta con scarico a pressione klik-clak.
 Art. BIBLIO22
 Peso vasca: 152 kg.
 Capacità: 288 L.
 Art. BIBLIO23
 Peso vasca: 160 kg.
 Capacità: 362 L.

*Rectangular Corian bathtub with back rim for tap mounting, complete with regulating feet and drain with pressure plug.
 Art. BIBLIO22
 Weight: 152 kg.
 Capacity: 288 L.
 Art. BIBLIO23
 Weight: 160 kg.
 Capacity: 362 L.*



	H	P	L	art.
	53,5	90	180	BIBLI062
		100	190	BIBLI063

Vasca da bagno rettangolare in Corian con vani a giorno frontali e bordo per rubinetteria laterale dx o sx, completa di piedini regolabili e piletta con scarico a pressione klik-clak.

Art. BIBLI062

Peso vasca: 158 kg.

Capacità: 288 L.

Art. BIBLI063

Peso vasca: 167 kg.

Capacità: 362 L.

Rectangular Corian bathtub with front open shelves and right or left side rim for tap mounting, complete with regulating feet and drain with pressure plug.

Art. BIBLI062

Weight: 158 kg.

Capacity: 288 L.

Art. BIBLI063

Weight: 167 kg.

Capacity: 362 L.

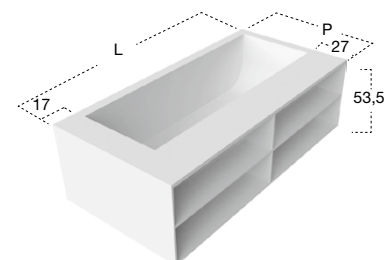

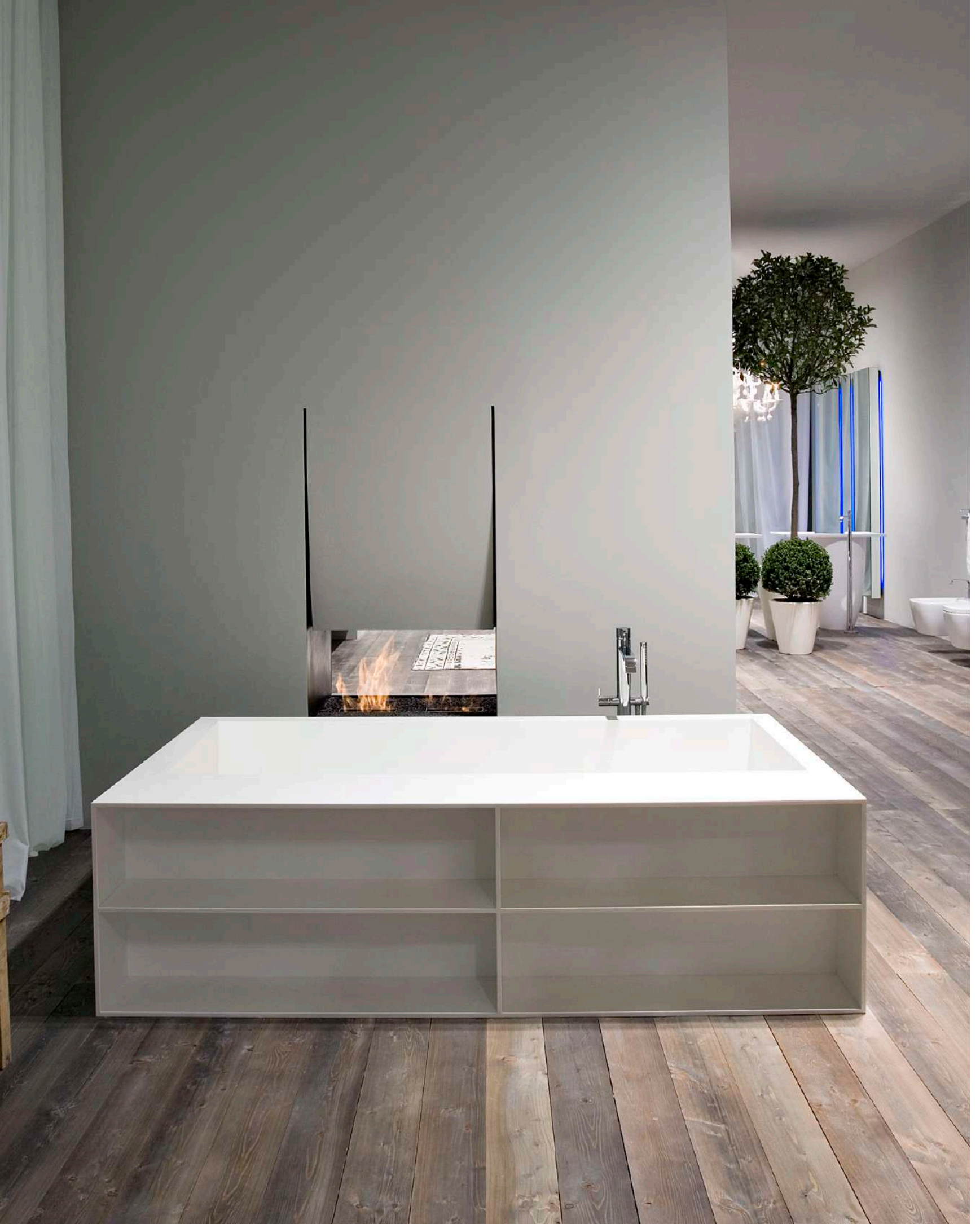



H	P	L	art.
53,5	90	170	BIBLI052
	100	180	BIBLI053

Vasca da bagno rettangolare in Corian, con vani a giorno frontali, completa di piedini regolabili e piletta con scarico a pressione klik-clak.

Art. BIBLI052

Peso vasca: 128 kg.

Capacità: 288 L.

Art. BIBLI053

Peso vasca: 133 kg.

Capacità: 362 L.

Rectangular Corian bathtub with front open shelves, complete with regulating feet and drain with pressure plug.

Art. BIBLI052

Weight: 128 kg.

Capacity: 288 L.

Art. BIBLI053

Weight: 133 kg.

Capacity: 362 L.

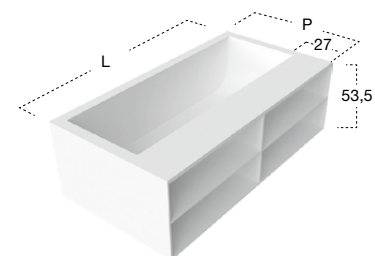





H	P	L	art.
53,5	90	180	BIBLIO64
	100	190	BIBLIO65

Vasca da bagno rettangolare in Corian, con vani a giorno frontali e bordo per rubinetteria dx o sx, rivestita su 4 lati con pannelli in multistrato impiallacciati in essenza di legno, completa di piedini regolabili e piletta con scarico a pressione klik-clak.

Art. BIBLIO64

Peso vasca: 122 kg.

Capacità: 288 L.

Art. BIBLIO65

Peso vasca: 133 kg.

Capacità: 362 L.

Rectangular Corian bathtub with front open shelves and right or left side rim for tap mounting, covered on 4 sides with plywood panels veneered with wood essence complete with regulating feet and drain with pressure plug.

Art. BIBLIO64

Weight: 122 kg.

Capacity: 288 L.

Art. BIBLIO65

Weight: 133 kg.

Capacity: 362 L.

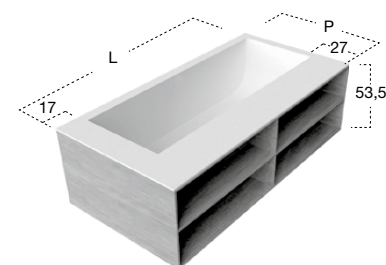

BIBLIO

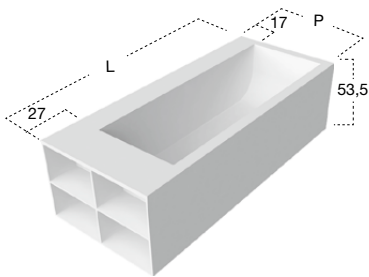

H	P	L	art.
53,5	80	190	BIBLI042
	90	200	BIBLI043

Vasca da bagno rettangolare in Corian, con bordo per rubinetteria sul retro e vani a giorno laterali dx o sx, completa di piedini regolabili e piletta con scarico a pressione klik-clak.
 Art. BIBLI042
 Peso vasca: 129 kg.
 Capacità: 288 L.
 Art. BIBLI043
 Peso vasca: 138 kg.
 Capacità: 362 L.

*Rectangular Corian bathtub with back rim for tap mounting and right or left side open shelves, complete with regulating feet and drain with pressure plug.
 Art. BIBLI042
 Weight: 129 kg.
 Capacity: 288 L.
 Art. BIBLI043
 Weight: 138 kg.
 Capacity: 362 L.*



H	P	L	art.
53,5	80	190	BIBLIO44
	90	200	BIBLIO45

Vasca da bagno rettangolare in Corian, con bordo per rubinetteria sul retro e vani a giorno laterali dx o sx, rivestita su 4 lati con pannelli in multistrato impiallacciati in essenza di legno, completa di piedini regolabili e piletta con scarico a pressione clik-clak.

Art. BIBLIO44

Peso vasca: 135 kg.

Capacità: 288 L.

Art. BIBLIO45

Peso vasca: 152 kg.

Capacità: 362 L.

Rectangular Corian bathtub with back rim for tap mounting and right or left side open shelves, covered on 4 sides with plywood panels veneered with wood essence complete with regulating feet and drain with pressure plug.

Art. BIBLIO44

Weight: 135 kg.

Capacity: 288 L.

Art. BIBLIO45

Weight: 152 kg.

Capacity: 362 L.

art. BRIDGE

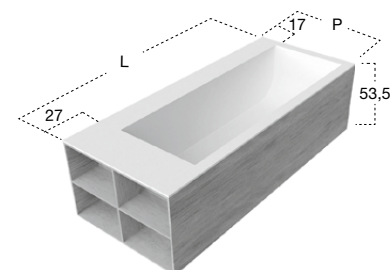
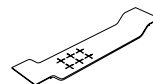



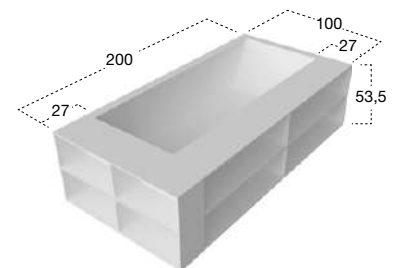

H	P	L	art.
53,5	100	200	BIBLIO103

Vasca da bagno rettangolare in Corian con vani a giorno frontali e laterali, completa di piedini regolabili e piletta con scarico a pressione klik-clak.

Peso vasca: 121 kg.

Capacità: 362 L.

Rectangular Corian bathtub with front and lateral open shelves, complete with regulating feet and drain with pressure plug.

Weight: 121 kg.

Capacity: 362 L.

BIBLIO

art. BIBLIO10/11/12/13/14/15

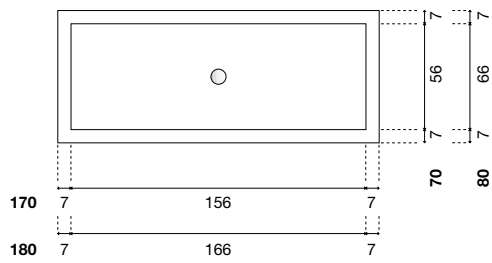

BIBLIO10 H 53,5 P 70 L 170 cm
BIBLIO11 H 53,5 P 80 L 180 cm

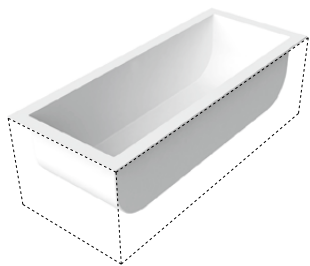

BIBLIO12 H 53,5 P 70 L 170 cm
BIBLIO13 H 53,5 P 80 L 180 cm



BIBLIO14 H 53,5 P 70 L 170 cm
BIBLIO15 H 53,5 P 80 L 180 cm



art. BIBLIO20/21/22/23/24/25

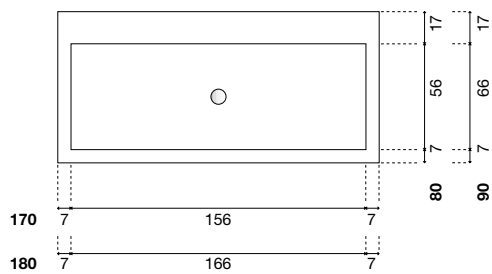

BIBLIO20 H 53,5 P 80 L 170 cm
BIBLIO21 H 53,5 P 90 L 180 cm

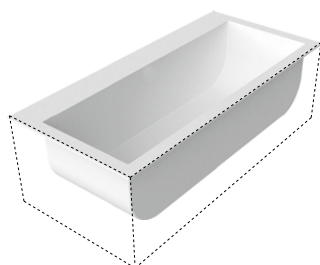

BIBLIO22 H 53,5 P 80 L 170 cm
BIBLIO23 H 53,5 P 90 L 180 cm

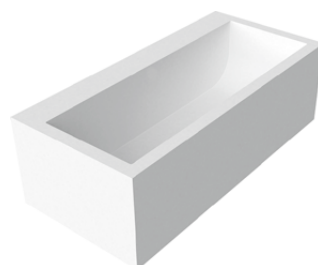

BIBLIO24 H 53,5 P 80 L 170 cm
BIBLIO25 H 53,5 P 90 L 180 cm



art. BIBLI030/31/32/33/34/35

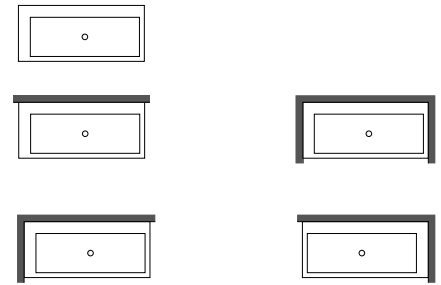
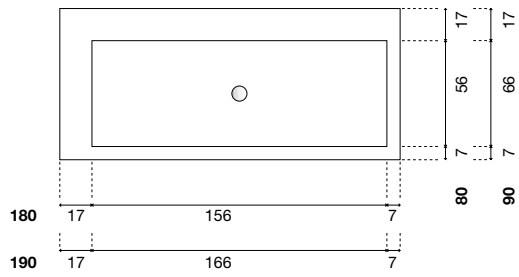

BIBLI030 H 53,5 P 80 L 180 cm
BIBLI031 H 53,5 P 90 L 190 cm

BIBLI032 H 53,5 P 80 L 180 cm
BIBLI033 H 53,5 P 90 L 190 cm

BIBLI034 H 53,5 P 80 L 180 cm
BIBLI035 H 53,5 P 90 L 190 cm

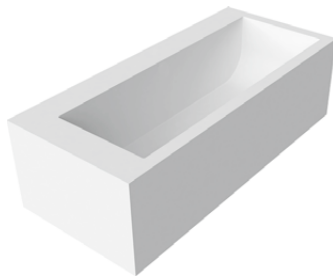
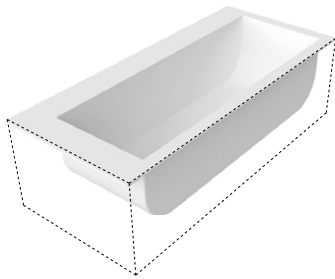

art. BIBLI042/43/44/45

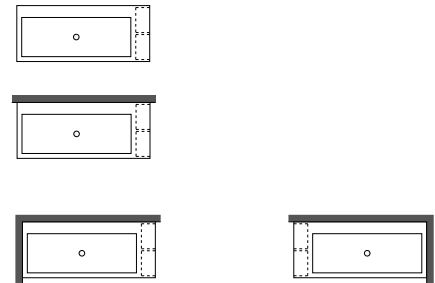
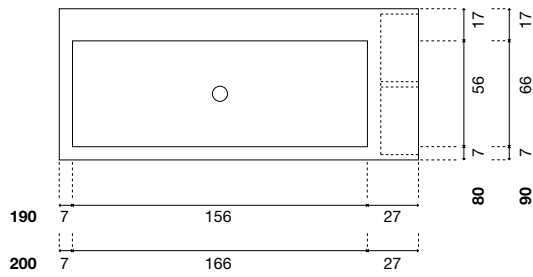

BIBLI042 H 53,5 P 80 L 190 cm
BIBLI043 H 53,5 P 90 L 200 cm

BIBLI044 H 53,5 P 80 L 190 cm
BIBLI045 H 53,5 P 90 L 200 cm

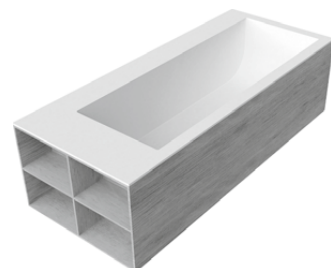
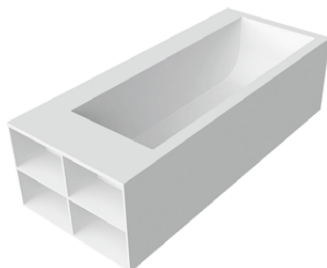

BIBLIO

art. BIBLI052/53/54/55

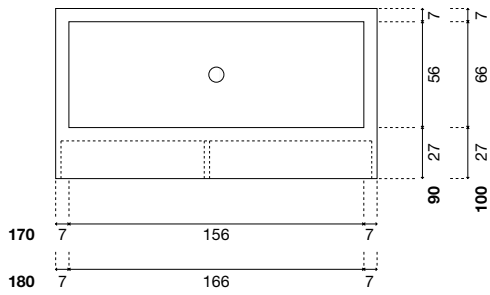

BIBLI052 H 53,5 P 90 L 170 cm
BIBLI053 H 53,5 P 100 L 180 cm

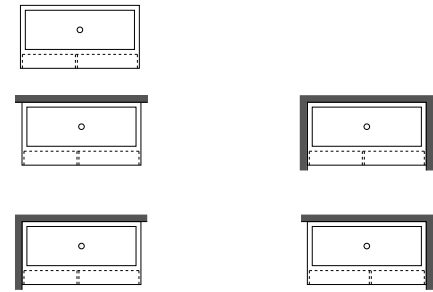
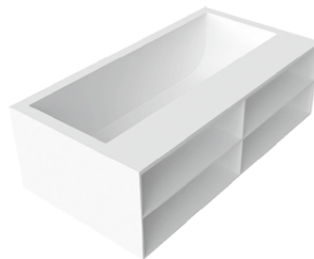

BIBLI054 H 53,5 P 90 L 170 cm
BIBLI055 H 53,5 P 100 L 180 cm

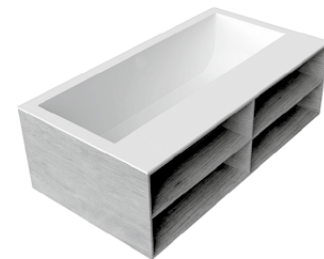

art. BIBLI060/61/62/63/64/65

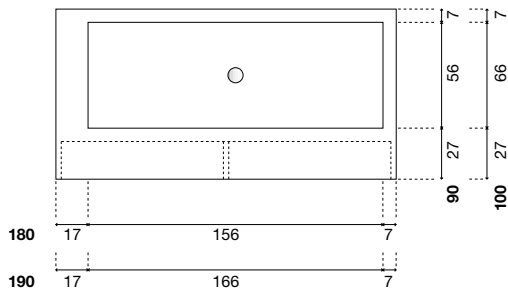

BIBLI060 H 53,5 P 90 L 180 cm
BIBLI061 H 53,5 P 100 L 190 cm

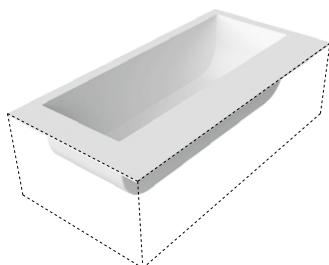

BIBLI062 H 53,5 P 90 L 180 cm
BIBLI063 H 53,5 P 100 L 190 cm

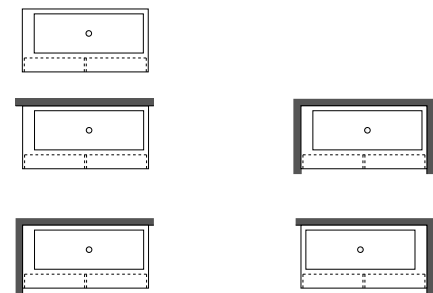
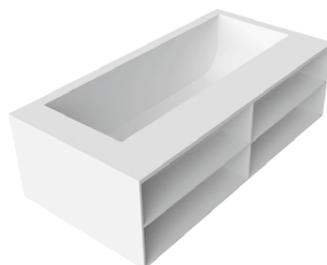

BIBLI064 H 53,5 P 90 L 180 cm
BIBLI065 H 53,5 P 100 L 190 cm

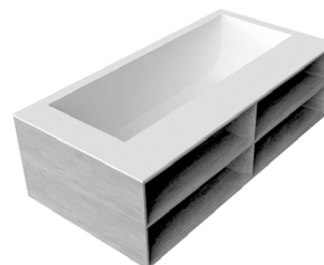

art. BIBLIO70/71

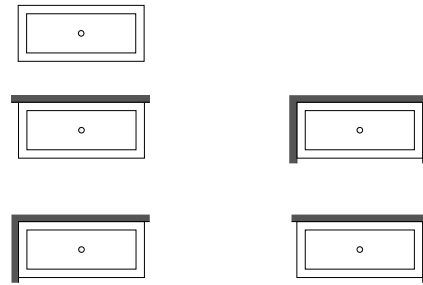
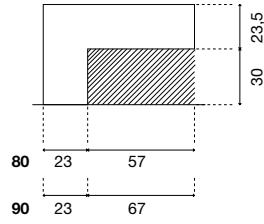
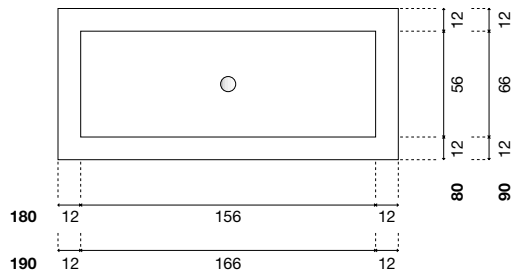

BIBLIO70 H 53,5 P 80 L 180 cm
BIBLIO71 H 53,5 P 90 L 190 cm

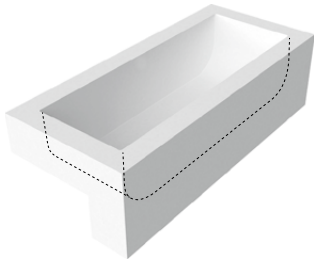

art. BIBLIO80/81

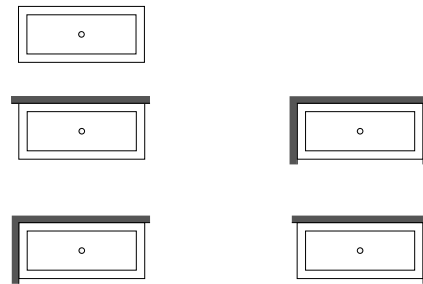
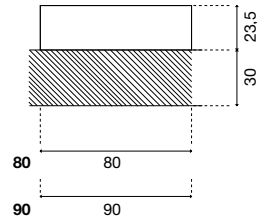
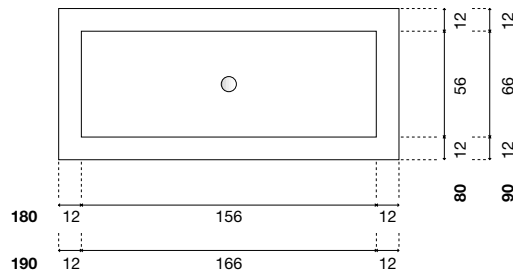

BIBLIO80 H 53,5 P 80 L 180 cm
BIBLIO81 H 53,5 P 90 L 190 cm

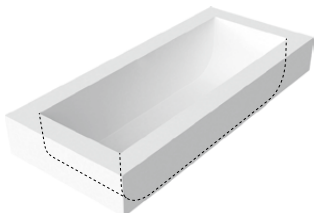

BIBLIO

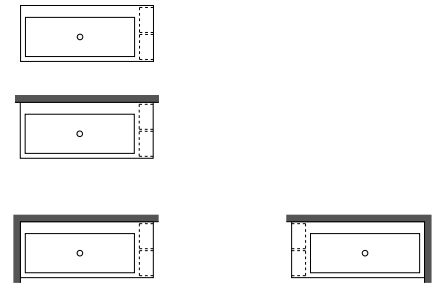
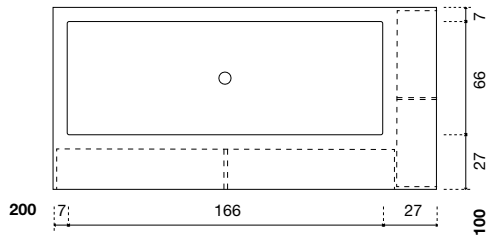

BIBLIO103 H 53,5 P 100 L 200 cm



art. BIBLIOXL

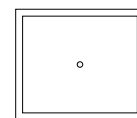
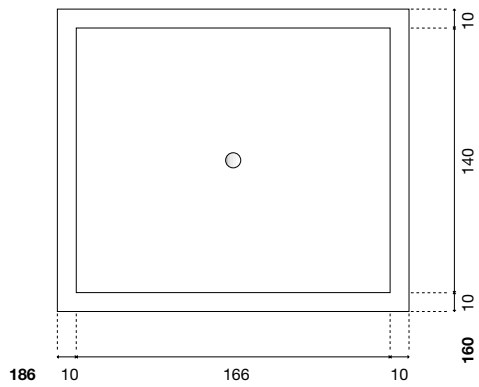

BIBLIOXL H 53,5 P 160 L 186 cm



Vista dall'alto del posizionamento del rubinetto sul bordo da 17 cm lato lungo vasca opzioni **A-B-C** degli Art. **BK701, BK702, AY701SA, AY701LU, AY702SA e AY702LU.**

*Top view of tap position on border 17 cm long side options **A-B-C** of Art. **BK701, BK702, AY701SA, AY701LU, AY702SA and AY702LU.***

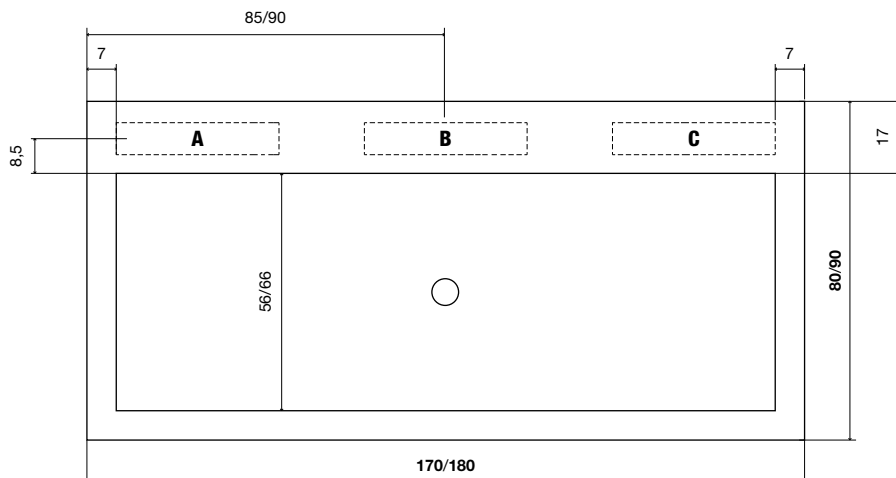

Vista dall'alto e laterale del posizionamento del rubinetto sul bordo da 17 cm lato corto vasca degli Art. **BK701, BK702, AY701SA, AY701LU, AY702SA e AY702LU.**

*Top and side view of tap position on center of border 17 cm short side of Art. **BK701, BK702, AY701SA, AY701LU, AY702SA and AY702LU.***

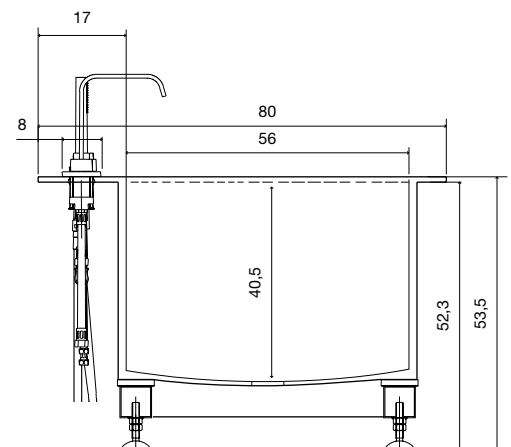
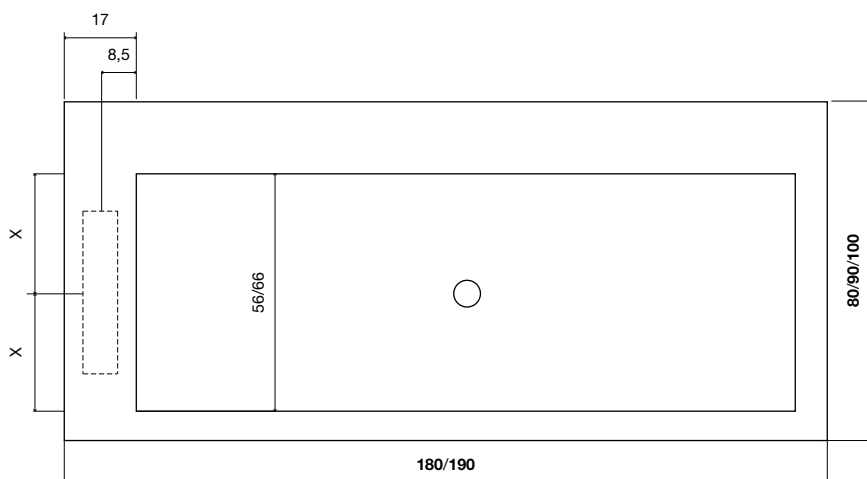

vasche / tubs

BIBLIO

art. BK701

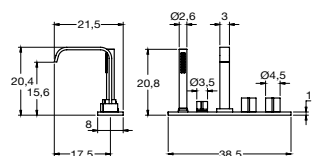

art. AY701SA
art. AY701LU

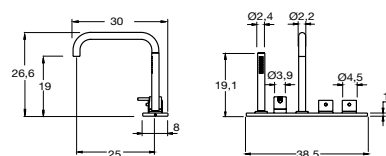

art. BK702



art. AY702SA
art. AY702LU

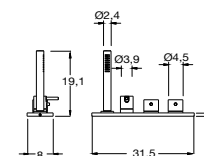

art. BK903N

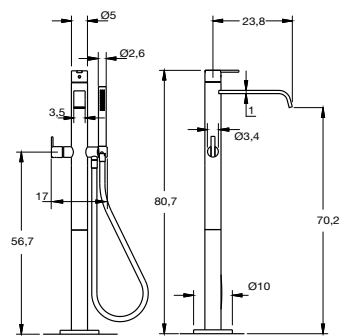

art. AY903SA
art. AY903LU

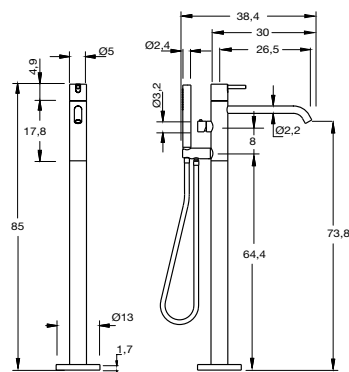

art. TB933

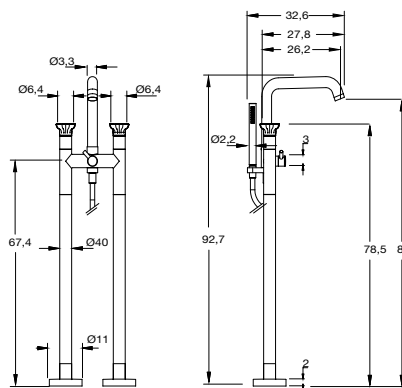

Tutti i modelli Art. **BIBLIO** sono corredati di un sistema di scarico illustrato di seguito, completo di troppopieno nascosto che funziona mediante l'utilizzo del principio dei vasi comunicanti (A), sifone (D), e piletta con scarico a pressione "klik-clak", che può svolgere anche la funzione di erogazione (B), da attivare solo in abbinamento ai rubinetti Art. **BK702, AY702SA, AY702LU** o a qualsiasi rubinetto bordo vasca sprovvisto di bocca di erogazione.

All models of the Art. **BIBLIO** bathtub come with a drainage system as illustrated below complete with a hidden overflow which functions utilizing the connection tubes (A), trap (D) and pressure plug which can also be used as a spout (B), to activate only in conjunction with Art. **BK702, AY702SA, AY702LU** or any bath rim mounting set without a bath spout according to instructions given below.

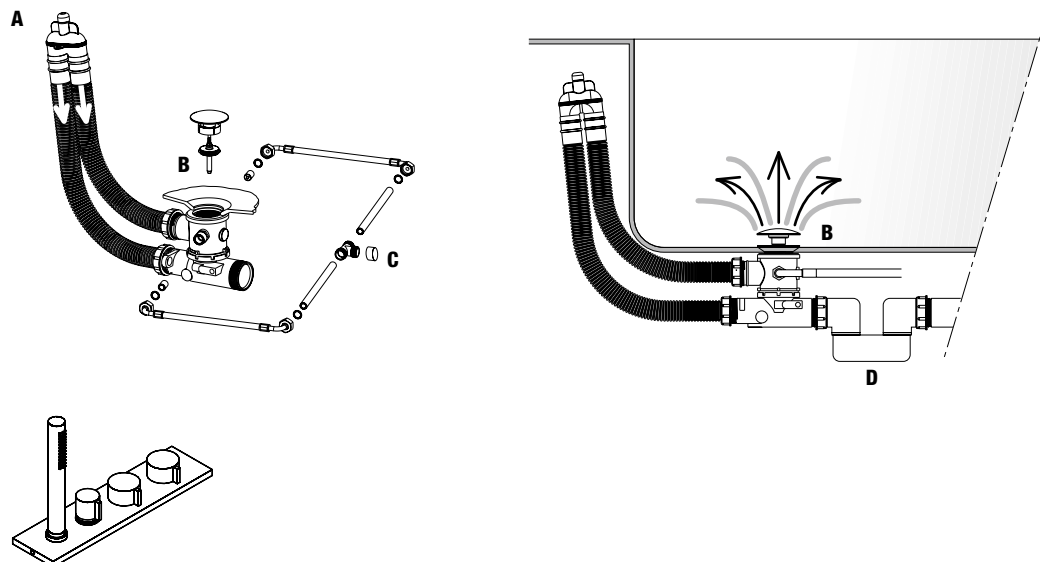

Con Art. **BK702 / AY702SA / AY702LU**

Per rendere attivo il sistema di erogazione direttamente dalla piletta di scarico (B), togliere il tappo "C" e collegare al carico dell'acqua.

With Art. **BK702 / AY702SA / AY702LU**

Remove cap "C" and connect to water outlet to activate directly from drain (B).

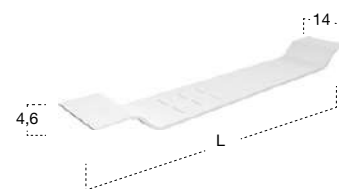

H	P	L	art.
4,6	14	70	BRIDGE10
4,6	14	80	BRIDGE11

Tavoletta sagomata in Corian portaoggetti, per vasca da bagno Art. BIBLIO.

Corian soap tray for bathtub Art. BIBLIO.

EPOQUE design Carlo Colombo

Una vasca scultorea, un blocco di pietra Amazzone scavato dall'acqua che si esprime attraverso linee semplici ed essenziali che originano una forma compiuta ed elegante. È parte integrante della collezione di mobili e contenitori Bespoke, ma è anche una vasca freestanding in grado di inserirsi al meglio in contesti contemporanei o di stile. Le superfici levigate di Epoque consentono di apprezzare la matericità della pietra e amplificano la sensazione di naturalezza e di relax che avvolge chi la utilizza. Semplicità e linearità delle forme consentono di riportare l'attenzione sull'essenza della materia e sui significati unici che è in grado di proporre sia dal punto di vista visivo che tattile. Le proporzioni armoniche definiscono un vaso dalle linee morbide ed accoglienti, la sua forma ovale si allunga fino ai bordi, per dar vita a un'immagine "leggera" che nasconde una fisicità importante.

A sculptural bathtub, a block of Amazzone stone carved with water expressed through simple and essential lines that originate a complete and elegant shape. An integral part of the collection Bespoke, a freestanding bathtub that fits well in contemporary contexts or styles. The polished surfaces of Epoque allow the appreciation of the stone and amplify the feeling of naturalness and relaxation that envelops the user. Simplicity and linear forms that allow your attention to focus on the essence of the matter and the unique meaning that is offered visually and by tactile. The harmonic proportions define a reservoir with soft and welcoming lines its oval shape stretching out to the borders to give life to a light image that hides an important physical presence.



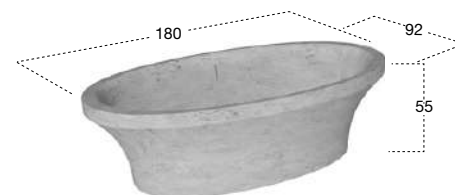

	H	P	L	art.
Pietra Amazzone	55	92	180	EPOQUE

Vasca da bagno ovale in pietra, completa di piletta con sistema di scarico a pressione clik-clak.
N.B. Per l'ispezione, si consiglia di realizzare un pozzetto esterno (vedere schede tecniche).

Peso vasca: 460 kg.

Capacità: 290 L.

Oval stone bathtub complete with drain and pressure plug.

P.S. We advise an exterior inspection window (see technical drawings).

Weight: 460 kg.

Capacity: 290 L.



Pietra Luna



Stone Grey

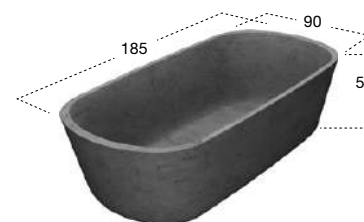

	H	P	L	art.
Pietra Luna / Stone Grey	50	90	185	BAiA

Vasca da bagno ovale in pietra, completa di piletta con sistema di scarico a pressione click-clack.

N.B. Per l'ispezione, si consiglia di realizzare un pozzetto esterno (vedere schede tecniche).

Peso vasca: 800 kg.

Capacità: 400 L.

Oval stone bathtub complete with drain and pressure plug.

P.S. We advise an exterior inspection window (see technical drawings).

Weight: 800 kg.

Capacity: 400 L.







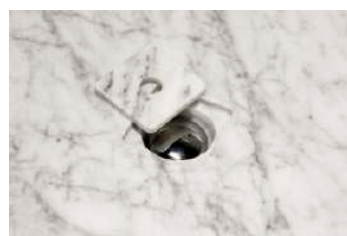

	H	P	L	art.
Marmo di Carrara / Stone Grey / Nero Marquinia	55	130	190	SOLIDEA190
Marmo di Carrara / Stone Grey / Nero Marquinia	55	130	210	SOLIDEA210

Vasca da bagno ovale in pietra, completa di piletta con sistema di scarico a pressione click-clack.

N.B. Per l'ispezione, si consiglia di realizzare un pozzetto esterno (vedere schede tecniche).

Art. SOLIDEA190

Peso vasca: 900 kg.

Capacità: 550 L.

Art. SOLIDEA210

Peso vasca: 950 kg.

Capacità: 620 L.

Oval stone bathtub complete with drain and pressure plug.

P.S. We advise an exterior inspection window (see technical drawings).

Art. SOLIDEA190

Weight: 900 kg.

Capacity: 550 L.

Art. SOLIDEA210

Weight: 950 kg.

Capacity: 620 L.

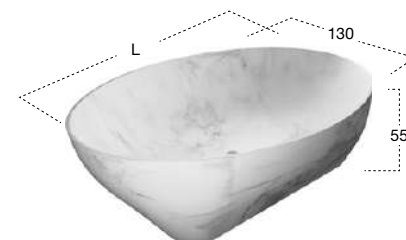

VASCABARCA/BARCAVASCA design Anne e Patrick Poirier

Per compiere un viaggio ci vuole un mezzo ma il viaggio si può compiere anche stando fermi, rilassandosi e spostandosi solo con la fantasia, esplorando con la mente nuovi territori, immergendosi nella storia e nella cultura di un paese.

Una limited edition, un gesto scultoreo che prende forma e diventa oggetto, un blocco di pietra Stone Grey scavato e modellato per dare forma a uno scafo affusolato. Vascabarca/ barcavasca è una vasca dall'immagine simbolica ed evocativa, è un blocco massiccio del peso di 1600 kg con un ampio bordo a prua che permette di appoggiare accessori e oggetti. La fisicità e il peso della pietra naturale riflettono il significato dell'oggetto, chiamato a un dialogo con l'acqua opposto rispetto alle normali convenzioni. La barca che dovrebbe galleggiare e non imbarcare acqua finisce di fatto per ospitarla, insieme con il suo equipaggio, che potrà goderne gli effetti rilassanti e rigeneranti. Perfetta per l'esterno è disponibile in dieci esemplari numerati e firmati dagli artisti.

To make a journey you need a means or the journey can be made at a standstill, relaxing and moving only with your fantasy exploring new territories with your mind immersed in history and culture of a country.

A limited edition, a sculptural gesture that takes shape and become an object, a block of Stone Grey carved and molded to give shape to a streamlined hull. Vascabarca / barcavasca is symbolic and evocative, a solid block of stone weighing 600 kg with a wide border in the bow to support accessories and objects. Perfect also for outdoors, ten pieces available numbered and signed by the artist.





EDIZIONE LIMITATA / LIMITED EDITION

	H	P	L	art.
Stone Grey	56	140	260	VASCABARCA/BARCAVASCA

Vasca da bagno completa di piletta con sistema di scarico a pressione click-clack.

N.B. Per l'ispezione, si consiglia di realizzare un pozzetto esterno (vedere schede tecniche).

Peso vasca: 1.600 kg.

Capacità: 400 L.

Di quest'opera saranno realizzati 10 esemplari in pietra, firmati e numerati in numeri romani dagli artisti; il committente potrà, se vorrà, personalizzare la propria vascabarca con un nome a sua scelta che sarà inciso a poppa.

Stone bathtub complete with drain and pressure plug.

P.S. We advise an exterior inspection window (see technical drawings).

Weight: 1.600 kg.

Capacity: 400 L.

Of this masterpiece only 10 pieces will be made out of stone, signed and numbered with roman numbers from the artists; the buyer can choose, if wishes, to personalize their own vascabarca with a name which can be carved at stern.



www.antoniolupi.it

Per essere costantemente informati su novità e prodotti in modo dettagliato, vi invitiamo a navigare nel nostro sito sempre aggiornato. Nell'area download potrete scaricare tutto il materiale tecnico ed informativo che vi necessita.

To constantly be up to date in a detailed manner on novelties and products please navigate through our website. In the download area you can find all the necessary technical information.



Scarica l'App su iTunes e Google Play per entrare nel mondo antoniolupi

Download the App on iTunes and Google Play to discover the world of antoniolupi



Prodotto interamente in Italia.

Entirely made in Italy.

© Antonio Lupi Design S.p.A. 2018

NOTA: alla Antonio Lupi Design S.p.A. è riservata la facoltà di apportare ai propri modelli qualsiasi modifica estetica, tecnica, nelle dimensioni e nei colori, ritenuta necessaria, nonché la facoltà di sospendere la produzione in qualunque momento senza preavviso, rinunziata fin d'ora da parte del committente ogni conseguente richiesta risarcitoria. Si declina ogni responsabilità relativa ad eventuali inesattezze contenute in questo catalogo, se dovute ad errori di stampa o trascrizioni. Nessun contenuto di questo catalogo può essere copiato, riprodotto anche parzialmente, ripubblicato, trasmesso o distribuito in qualunque forma, senza autorizzazione scritta dell'Antonio Lupi Design S.p.a.

NOTE: Antonio Lupi Design S.p.A. reserves the right to make any and all necessary esthetic, technical, colour or size modifications in order to enhance use and esthetic value, and may suspend the production cycle at any moment without notice. Such instances may not be subject to claim by the client. We decline all responsibilities for any possible uncertainties due to misprints in this catalogue. None of the material in this catalogue can be copied, reproduced, republished or distributed in any or partial way unless a written authorization is given from the company Antonio Lupi Design S.p.a.

antoniolupi

73
VIA MAZZINI
75

Antonio Lupi Design S.p.A.
via Mazzini 73/75 - 50050 Stabbia
Cerreto Guidi (Firenze) - Italy
T +39 0571 586881 05654
F +39 0571 586885
www.antoniolupi.it
lupi@antoniolupi.it

